



This is a digital copy of a book that was preserved for generations on library shelves before it was carefully scanned by Google as part of a project to make the world's books discoverable online.

It has survived long enough for the copyright to expire and the book to enter the public domain. A public domain book is one that was never subject to copyright or whose legal copyright term has expired. Whether a book is in the public domain may vary country to country. Public domain books are our gateways to the past, representing a wealth of history, culture and knowledge that's often difficult to discover.

Marks, notations and other marginalia present in the original volume will appear in this file - a reminder of this book's long journey from the publisher to a library and finally to you.

Usage guidelines

Google is proud to partner with libraries to digitize public domain materials and make them widely accessible. Public domain books belong to the public and we are merely their custodians. Nevertheless, this work is expensive, so in order to keep providing this resource, we have taken steps to prevent abuse by commercial parties, including placing technical restrictions on automated querying.

We also ask that you:

- + *Make non-commercial use of the files* We designed Google Book Search for use by individuals, and we request that you use these files for personal, non-commercial purposes.
- + *Refrain from automated querying* Do not send automated queries of any sort to Google's system: If you are conducting research on machine translation, optical character recognition or other areas where access to a large amount of text is helpful, please contact us. We encourage the use of public domain materials for these purposes and may be able to help.
- + *Maintain attribution* The Google "watermark" you see on each file is essential for informing people about this project and helping them find additional materials through Google Book Search. Please do not remove it.
- + *Keep it legal* Whatever your use, remember that you are responsible for ensuring that what you are doing is legal. Do not assume that just because we believe a book is in the public domain for users in the United States, that the work is also in the public domain for users in other countries. Whether a book is still in copyright varies from country to country, and we can't offer guidance on whether any specific use of any specific book is allowed. Please do not assume that a book's appearance in Google Book Search means it can be used in any manner anywhere in the world. Copyright infringement liability can be quite severe.

About Google Book Search

Google's mission is to organize the world's information and to make it universally accessible and useful. Google Book Search helps readers discover the world's books while helping authors and publishers reach new audiences. You can search through the full text of this book on the web at <http://books.google.com/>

TA
405
13.2

HARVARD UNIVERSITY



FRANCES LOEB LIBRARY
GRADUATE SCHOOL OF DESIGN

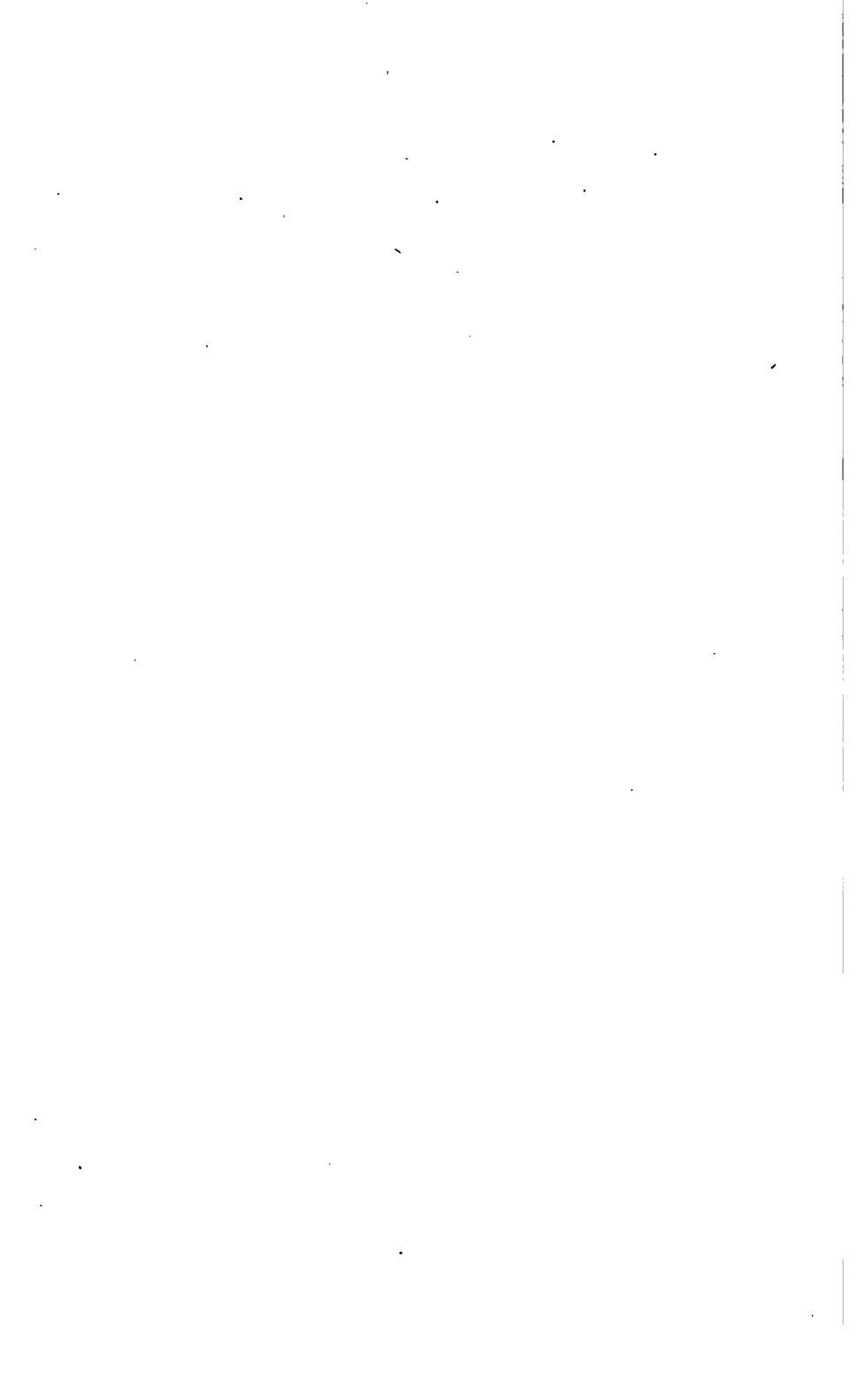

**THE
STRENGTH OF MATERIALS**

CAMBRIDGE UNIVERSITY PRESS WAREHOUSE,

C. F. CLAY, MANAGER.

London: FETTER LANE, E.C.

Glasgow: 50, WELLINGTON STREET.



Leipzig: F. A. BROCKHAUS.

New York: THE MACMILLAN COMPANY.

Bombay and Calcutta: MACMILLAN & CO. LTD.

[All Rights reserved.]

THE
STRENGTH OF MATERIALS

BY

J. A. EWING. M.A., LL.D., F.R.S., M.INST.C.E.

DIRECTOR OF NAVAL EDUCATION.

SECOND EDITION

CAMBRIDGE
AT THE UNIVERSITY PRESS

1906

~~Eng 319.06~~

~~3G
29~~

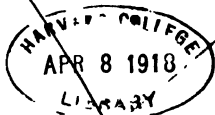

Treadwell fund

TA
405

13.2

**DISCARDED BY
GORDON MCKAY LIBRARY**

*First Edition 1899.
Second Edition 1903.
Reprinted 1906.*

HARVARD UNIVERSITY.

MAY 11 1987

Frances Loeb Library
Graduate School of Design

ADE S213

TA
405
.E94X

Cambridge:
PRINTED BY JOHN CLAY, M.A.
AT THE UNIVERSITY PRESS.

5-9694
5

PREFACE TO THE FIRST EDITION.

IN modern schools of Engineering a student acquires his knowledge of the Strength of Materials and of its application in design, partly by hearing lectures, partly by making experiments in the laboratory, and partly by working out examples in the drawing-office. The present treatise is an attempt to set forth briefly a lecture-room treatment of the subject, which to be effective must be supplemented by laboratory and drawing-office work. Indications are also given of some laboratory experiments in elasticity, and a number of pieces of apparatus are described which have proved serviceable at Cambridge.

I am indebted to Messrs A. and C. Black for permission to use the substance of the article "Strength of Materials" which I wrote for the Ninth Edition of the *Encyclopaedia Britannica*. Also to Professor Unwin, and his publishers Messrs Longmans, for the illustrations on page 77, which are taken from his valuable Treatise on the Testing of Materials. To Mr T. Peel of Magdalene College I owe much for his kindness and care in reading the proofs of these sheets.

J. A. EWING.

ENGINEERING LABORATORY, CAMBRIDGE.

October, 1899.

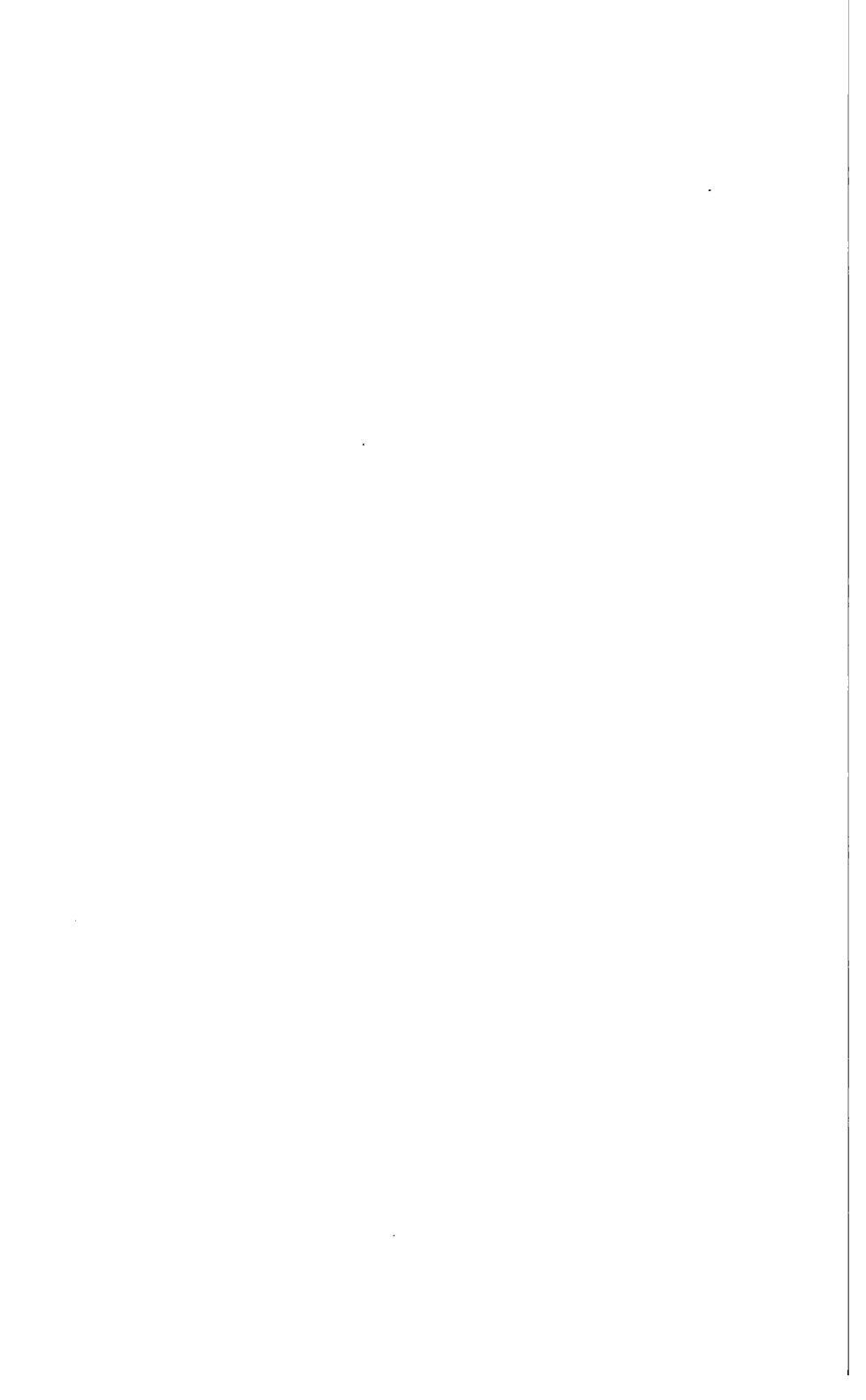

CONTENTS.

CHAPTER I.

STRESS AND STRAIN.

ART.	PAGE
1. Introductory	1
2. Stress	2
3. State of Stress	2
4. Condition of Equilibrium	2
5. Distribution of Stress. Intensity of Stress	3
6. Normal and Tangential Stress	3
7. State of Simple Push or Pull	4
8. Complex states of Stress. Principal Stresses	4
9. Character of the Stress in Simple Push or Pull	5
10. Combination of two simple pull or push stresses in directions at right angles to one another	6
11. State of Simple Shear	7
12. Equality of Shearing Stress in two directions	9
13. Fluid Stress	10
14. Strain	10
15. Elastic Strain and Permanent Set. Limits of Elasticity	10
16. Hooke's Law	11
17. Young's Modulus or the Stretch Modulus	12
18. Ratio of Lateral Contraction to Longitudinal Extension in Simple Pull	12
19. Strain produced by Shearing Stress. Modulus of Rigidity or Shear Modulus	13
20. Modulus of Cubic Compressibility or Bulk Modulus	13
21. Relation between the Moduluses of Elasticity	14
22. Work done in producing an Elastic Strain: Resilience	14

CHAPTER II.

RELATIONS BETWEEN THE ELASTIC CONSTANTS.

ART.	PAGE
23. Relation between E , C , and K in Isotropic Materials	16
24. Relation of σ to the modulus C and K	18
25. Other expressions of relation between the Elastic Constants	19
26. Equations connecting Stresses and Strains	20
27. State of Simple Shear	21
28. Volume Strain	21
29. Simple Strain along one axis	22
30. Lateral Strain prevented in one direction	22
31. Numerical Example	23

CHAPTER III.

ULTIMATE STRENGTH AND NON-ELASTIC STRAIN.

32. Strain carried beyond the Limit of Elasticity	24
33. Ultimate Strength	25
34. Factor of Safety	27
35. Variation of the Ultimate Strength under different modes of loading	28
36. Advantage of Plasticity	28
37. Ordinary Tensile Tests	29
38. Diagrams of Extension and Load in Tensile Tests	30
39. Autographic Diagrams of Extension and Load	32
40. Hardening effect of rest after overstraining	33
41. Breakdown and Recovery of Elasticity after overstraining	35
42. Effect of Heating in facilitating Recovery of Elasticity after overstraining	36
43. Influence of time in the process of testing	41
44. Effects of Hardening through overstrain	42
45. Annealing	43
46. Hardening and Tempering of Steel	44
47. Contraction of section at rupture	45
48. Non-elastic Extension	45
49. Crystalline Structure of Metals	46
50. Percentage of Extension in Tensile Tests	47
51. Forms of Test-Pieces	48
51 A. Fracture by tearing: Effect of Flaws	49
52. Comparative Strength of Long and Short Rods	50
53. Fracture by Tension or by Compression	51
54. Inclination of Surfaces of Shear in Tension and Compression Tests	52

ART.	PAGE
55. Fatigue of Metals	54
56. Imperfection of Elasticity	57
57. Cumulative Effect of Blows and Shocks	59
58. Initial Internal Stress	59
59. Influence of Temperature on Strength	60

CHAPTER IV.

THE TESTING OF MATERIALS.

60. Testing Machines	62
61. Single-Lever Machine with vertically placed Test-Piece	62
62. Calibration of Vertical Machines	66
63. Other Testing Machines using Weights and Levers	67
64. Other Testing Machines. Diaphragm Machines	70
65. Testing Machines for special purposes	72
66. Attachment of the specimens in tensile tests	73
67. Apparatus for drawing autographic diagrams of extension and load	75
68. Measurement of Young's Modulus by Extensometers	76
69. Measurement of Young's Modulus in Wire	84
70. Measurement of Young's Modulus by Bending	86
71. Measurement of the Modulus of Rigidity. Static Method	88
72. Measurement of the Modulus of Rigidity. Kinetic Method by Torsional Oscillations	90
73. Maxwell's Needle used as Torsional Oscillator	91
74. Results of Tests. Data for Cast-iron	93
75. Wrought-iron	94
76. Steel	95

CHAPTER V.

UNIFORM AND UNIFORMLY-VARYING DISTRIBUTIONS OF STRESS.

77. Use of the Stress Figure to represent a Stress distributed over a Surface	99
78. Uniformly distributed Stress	99
79. Uniformly-varying Stress	102
80. Uniformly-varying Stress forming a Couple	104
81. Analysis of any Uniformly-varying Stress into a uniform stress and a couple	105
82. Extent to which Stress may be Non-axial without reversing its sign at the edge of the stressed surface	106

ART.	PAGE
83. Simple Bending	107
84. Influence of Bending beyond the Elastic Limit on the Distribution of the Stress	109
85. Modulus of Rupture	110

CHAPTER VI.

STRESS IN BEAMS.

86. Character of the Stress in Beams	112
87. Stress due to Bending Moment	113
88. Particular Cases	114
89. Beam with Flanges and Web	115
90. Variation of Bending Moment and Shearing Force from point to point along a Beam. Diagrams of Bending Moment and Shearing Force	116
91. Graphic method of finding Bending Moments	123
92. Relation between the Bending Moment Diagram and the Funicular Polygon for the same system of Loads	123
93. Connection between Bending Moment and Shearing Force	125
94. Bending Moment and Shearing Force due to Moving Loads	126
95. Distribution of Shearing Stress over the Section of a Beam	127
96. Principal Stresses in a Beam	129

CHAPTER VII.

DEFLECTION OF BEAMS: CONTINUOUS BEAMS.

97. Curvature due to Bending Moment	132
98. Condition of uniform curvature	133
99. Relation of Curvature, Slope and Deflection	134
100. Examples of Slope and Deflection in Beams and Cantilevers	134
101. Deflection of a uniform beam under a single load placed anywhere	137
102. Transverse Bending. Anticlastic curvature	138
103. Resilience of a Beam	139
104. Graphic method in the treatment of Deflection	141
105. Additional Deflection due to Shearing	144
106. Continuous Beams	146
107. Theorem of Three Moments	149
108. Advantages of Continuous Beams	151
109. Combination of Cantilever with Beams	152
110. Encasté Beams	153

CHAPTER VIII.

FRAMES.

ART.	PAGE
111. Frames	157
112. Perfect, Imperfect, and Redundant Frames	158
113. Method of Sections	159
114. Graphic Process. Method of Reciprocal Figures	160
115. Examples of the Method of Reciprocal Figures	162
116. Use of the Funicular Polygon in finding the Reactions at the Supports	165
117. Special Cases	167
118. Use of Semi-members in Bridge Frames. Counter-bracing	169
119. Superposed Frames	172
120. Effects of Stiff Joints	173

CHAPTER IX.

STRUTS AND COLUMNS.

121. Instability under Compression	174
122. Bending of Long Columns. Euler's Theory	175
123. Fixed and Free Ends	177
124. Modification of Euler's theory to meet practical conditions	179
125. Values of the Constants in other materials	185
126. Struts with Lateral Load	187

CHAPTER X.

TORSION OF SHAFTS.

127. Torsion of a uniform circular shaft	190
128. Relation of the greatest intensity of stress to the twisting moment in solid and hollow circular shafts	191
129. Angle of Twist in Round Shafts	192
130. Relation of Power transmitted by a Shaft to Torsional Stress and Angle of Twist	193
131. Twisting combined with Bending	194
132. Resilience of a Round Shaft under Torsion	196
133. Torsion beyond the Elastic Limit	197
134. Spiral Springs	198
135. Helix in which the obliquity is considerable	199
136. Torsion of non-circular shafts	202
137. Stability of Shafts under End Thrust and Torsion	203
138. Centrifugal whirling of shafts	204

CHAPTER XI.

SHELLS AND THICK CYLINDERS.

ART.	PAGE
139. Stress in a Thin Shell due to Internal Pressure	207
140. Longitudinal Stress in Cylinder exposed to Internal Pressure	209
141. Spherical Shell	210
142. Cylindrical Shell of oval section	210
143. Thick Circular Cylinder	211
144. Thick Cylinder exposed to External Pressure	214
145. Use of Initial Internal Stress in strengthening a thick tube	214
146. Stress in a Revolving Ring	217
147. Stress in a Revolving Disc	218

CHAPTER XII.

HANGING CHAINS AND ARCHED RIBS.

148. Loaded Chain	221
149. Parabolic Chains	223
150. Common Catenary: Uniform Chain loaded with its own weight	224
151. Suspension Bridge with Stiffening Girder	226
152. Inverted Chain. The Arch	231
153. Arched Rib	233
154. Rib hinged at the ends and centre	234
155. Rib hinged at the ends only	236
156. Rib fixed at the ends	239

APPENDIX.

Table I. Strength to resist Tension	241
Table II. Strength to resist Crushing	243
Table III. Strength to resist Shearing	243
Table IV. Moduluses of Elasticity	243
Table V. Approximate Weights of Materials	244
Index	245

CHAPTER I.

STRESS AND STRAIN.

1. Introductory. The term "Strength of Materials" is used in a somewhat wide sense to name that part of the Theory of Engineering which deals with the nature and effects of stresses in the several parts of engineering structures. When a structure is loaded, that is to say, when forces of any kind are applied to it, the applied forces cause the parts of the structure to be stressed in various ways. Unless the parts are severally strong enough and stiff enough to bear these stresses the structure fails. To determine beforehand what loads the structure will bear safely, or conversely to design a structure which will be safe under a given set of loads, requires two things. We must be able to analyse the stresses in the various parts of the structure and by determining their relation to the applied loads to calculate their amounts. And further, we must know by experiment the properties of the materials which form the structure, both as to strength and as to stiffness, in order to judge after the action of the load has been analysed, what dimensions should be given to the parts to make them individually safe, and to prevent the structure as a whole from being unduly strained out of shape.

Hence the subject has two sides. On one hand, it is experimental and deals with the properties which materials are found to possess as to strength and elasticity. On the other, it is mathematical and discusses the kinds of stress to which the pieces of structures are subject, and also the changes of form which occur in consequence of the fact that all materials are more or less elastic.

2. Stress. Stress is the mutual action between two bodies, or between two parts of a body, whereby each of the two exerts a force upon the other.

Thus when a stone lies upon the ground there is at the surface of contact a stress, one aspect of which is the force which the stone exerts upon the ground, pushing the ground downwards, and the other aspect is the equal force directed upwards which the ground exerts upon the stone. Newton's "Third Law," that "action and reaction are equal and opposite," may be paraphrased by the statement that every force is one aspect of a stress. A stress may exist between two separate bodies, or between portions of a single body separated only by an imaginary surface of division. In a tie-rod, for instance, which is bearing a pull there is a stress between the two parts into which the rod may be imagined to be divided by any plane of cross-section: each part exerts a pull upon the other part across the plane.

3. State of Stress. A body is said to be in a state of stress when there is stress between the two parts which lie on opposite sides of any imaginary dividing surface. Thus the tie-rod of the last example is a body in a state of stress because there is a pull between the parts into which the rod is cut by any imaginary surface of cross-section.

A pillar or block supporting a weight is in a state of stress because at any cross-section the part above the section pushes down against the part below, and the part below pushes up against the part above. A plate of metal that is being cut in a shearing machine is in a state of stress, because at the plane which is about to give way by shearing the portion of metal on either side is tending to drag the portion on the other side with a force in that plane.

4. Condition of Equilibrium. The kind and amount stress which exists over any surface within a body at rest is general to be determined by considering that if the body is conceived to be divided into two parts *A* and *B* by the surface in question the force which *A* exerts upon *B* across the surface must equilibrate all the other forces which act on *B*, namely, the loads or external forces which are applied to it, including its weight and any forces which are exerted on it by its supports. Similarly the forces which act on *A* must when taken together be

in equilibrium, and the forces exerted by *B* upon *A* must balance the other forces which act on *A*. Thus the stress between *A* and *B* may be investigated by considering the equilibrium of either *A* or *B*.

5. Distribution of Stress. Intensity of Stress. A stress acting at a surface is distributed over it, each square inch or other portion of the surface bearing so much. The distribution may or may not be uniform. If it is uniform every square inch or other unit of area in the surface bears the same amount of the stress as every other. The intensity of stress, by which is meant the amount of stress per unit of area, is in that case found by dividing the whole stress by the whole area. Thus if a stress of *P* tons is uniformly distributed over a surface of *S* square inches, the intensity *p* in tons per square inch is given by the equation

$$p = \frac{P}{S}.$$

When the distribution is not uniform there is still a definite intensity of stress at any point in the surface, the value of which is

$$\frac{\delta P}{\delta S}$$

where δS is an indefinitely small area surrounding the point and δP is the stress acting on that small area. For practical purposes the intensity of a stress is usually expressed in tons weight per square inch, lbs. weight per square inch, or kilogrammes weight per square millimetre or per square centimetre*.

6. Normal and Tangential Stress. When a solid body is in a state of stress the direction of the stress at any imaginary surface of division may have any inclination to the surface; it may be normal to the surface, or tangential to it, or oblique. A stress the direction of which is oblique to the surface is most conveniently treated by resolving it into normal and tangential components. Thus if p_r (fig. 1) be the intensity

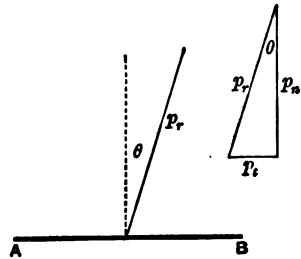

Fig. 1.

* One ton per square inch = 2240 lbs. per square inch = 157.2 kilos per square centimetre.

of stress on the surface AB , the direction of the stress making an angle θ with the normal to the surface, this oblique stress is equivalent to a normal stress p_n together with a tangential stress p_t , the intensity of the normal component being

$$p_n = p_r \cos \theta$$

and that of the tangential component

$$p_t = p_r \sin \theta.$$

Normal stress may consist either of push (compressive stress) or of pull (tensile stress): if a stress of pull be taken as positive a stress of push will be negative. Normal stress tends to make the portions which lie on the two sides of the surface directly recede from each other if it is positive, or directly approach each other if it is negative.

Stress which is tangential to the surface is often called Shearing Stress. It tends to make the material on one side of the surface slide past the material on the other.

7. State of Simple Push or Pull. The simplest possible state of stress is that of a short pillar or block compressed by opposite forces applied at its ends, or that of stretched rope or other tie. In these cases the stress is wholly in one direction. These cases may be distinguished as simple push and simple pull. In them there is no stress on planes parallel to the direction of the applied forces.

8. Complex states of Stress. Principal Stresses. A more complex state of stress occurs if the block (which for simplicity of statement we may assume to have a rectangular cross-section) is compressed or extended by forces applied to a pair of opposite sides, as well as by forces applied to its ends—that is to say, if two simple push or pull stresses in different directions act together. A still more complex state occurs if a third push or pull be applied to the remaining pair of sides. It may be shown that any state of stress which can possibly exist at any point of a body may be produced by the joint action of three simple stresses of push or pull in three suitably chosen directions at right angles to each other. These three are called *principal stresses*, and their directions are called the *axes of principal stress*. The axes of principal stress have the important property that the intensity of stress along one of them is greater, and along another is less, than in any other direction. These

are called respectively the axes of greatest and least principal stress. We shall have examples later on of more or less complex modes of stress, in which it will be important to calculate the principal stresses, since the greatest principal stress measures the greatest intensity which the material has to bear.

9. Character of the Stress in Simple Push or Pull.

Returning now to the state of stress which is produced by a single simple pull or push, let AB (fig. 2) be a portion of a tie or strut which is being pulled or pushed in the direction of the axis AB with a total stress P uniformly distributed. On any plane section CD taken at right angles to the axis there is a normal pull or push of intensity

$$p = \frac{P}{S},$$

S being the area of the normal cross-section. On such a plane there is no tangential stress. But on any plane EF whose normal is inclined to the axis, the stress is still in the direction of the axis, and is therefore oblique to the plane EF . Hence on such a plane there is tangential as well as normal stress. Let θ be the angle which the normal to the inclined section EF makes with the direction AB along which the stress acts. The area of the inclined section is

$$S' = \frac{S}{\cos \theta}.$$

The total stress P acting on this area may be resolved into the normal component

$$P_n = P \cos \theta,$$

and the tangential component

$$P_t = P \sin \theta.$$

Dividing these by the area S' over which they act we find the intensities of the components as follows:—The intensity of the normal stress on EF is

$$p_n = \frac{P \cos \theta}{S'} = \frac{P}{S} \cos^2 \theta = p \cos^2 \theta,$$

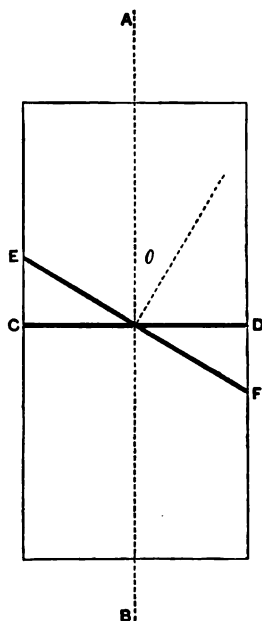

Fig. 2.

there are two principal stresses only, one equal and opposite to the other. These two principal stresses give rise to a stress which is wholly tangential on the two planes inclined at 45° to the axes of principal stress, and the intensity of the tangential stress on each of these planes is equal to the intensity of either of the principal stresses.

The state of simple shear may also be arrived at in another way. Let a cubical block or an elementary cubical part of any solid body (fig. 4) have tangential stresses QQ applied to one pair of opposite faces, A and B , and equal tangential stresses applied to a second pair of faces C and D , as in the figure. The effect is to set up a state of simple shear. On all planes parallel to A and B there is nothing but tangential stress and the same is true of all planes parallel to C and D . The intensity of the stress on both systems of planes is equal throughout to the intensity which was applied to the face of the block.

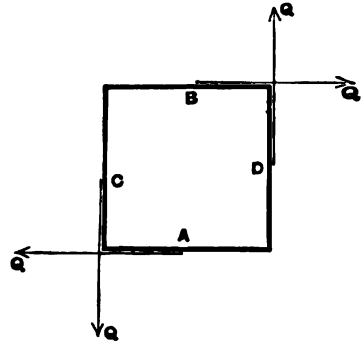

Fig. 4.

To see the connection between these two ways of specifying a

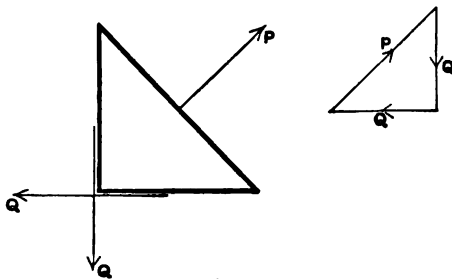

Fig. 5.

state of simple shear we have only to consider the equilibrium of the parts into which the block may be divided by ideal diagonal planes of section. To balance the forces QQ (fig. 5), there must be normal pull on the diagonal plane, the amount of which is $P = \sqrt{2}Q$. But the area of the surface over which P acts is greater than that of the surface over which Q acts in the proportion

which P bears to Q , and hence the intensity of P is the same as the intensity of Q .

Again, taking the other diagonal plane (fig. 6), precisely the same argument applies except that here the normal force P required for equilibrium is a push instead of a pull. Its intensity has the same value as before. Thus the state of simple shearing stress defined as consisting of two equal tangential stresses on two planes at right angles to one another is found to admit of analysis into two equal principal stresses, one of push and one of pull, acting in directions at right angles to one another and inclined at 45° to the directions of the shearing stress, just as the combination of a push with an equal pull at right angles to it has already been found to set up a state of simple shear.

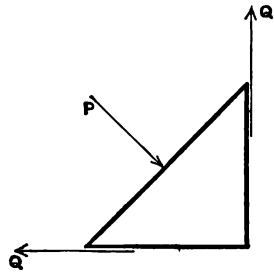

Fig. 6.

12. Equality of Shearing Stress in two directions. No tangential stress, whether occurring by itself or as the tangential component of an oblique stress, can exist in one direction without an equal intensity of tangential stress existing in another direction at right angles to the first. To prove this it is sufficient to consider the equilibrium of an indefinitely small cube (fig. 7), with one pair of sides parallel to the direction of the shearing stress. This stress, acting on two opposite sides, produces a couple which tends to rotate the cube. No arrangement of normal stresses on any of the three pairs of sides of the cube can balance this couple; that can be done only by a shearing stress Q' whose direction is at right angles to the first stress Q , and to the surface on which Q acts, and whose intensity is the same as that of Q . The argument is equally valid whether these tangential stresses act alone or as the tangential components of oblique stresses, and also whether there is or is not other stress on

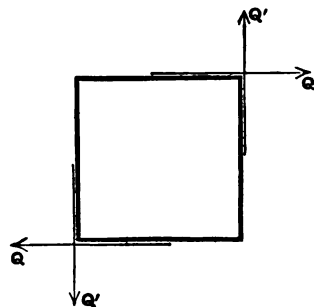

Fig. 7.

the remaining faces of the cube. If Q and Q' act alone we have the condition of simple shear described in the last paragraph.

13. Fluid Stress. Another important case is found when there are three principal stresses all of the same sign and of equal intensity p . It may be shown that the tangential components on a plane inclined in any direction cancel each other. There is no shearing stress anywhere; the stress on every plane is wholly normal and its intensity is p . This is the only state of stress that can exist in a mass of fluid at rest, in consequence of the fact that a fluid can exert no statical resistance to shear. For this reason the state is often briefly described as a fluid stress.

14. Strain. Strain is the change of shape produced by stress. If the stress is a simple longitudinal pull, the strain consists of lengthening in the direction of the pull, accompanied by contraction in both directions at right angles to the pull. If the stress is a simple push, the strain consists of shortening in the direction of the push with expansion in both directions at right angles to that; the stress and the strain are then exactly the reverse of what they are in the case of simple pull. If the stress is one of simple shear, the strain consists of a distortion such as would be produced by the sliding of layers in the direction of the shearing stresses.

15. Elastic Strain and Permanent Set. Limits of Elasticity. A material is elastic with regard to any applied stress if the strain disappears when the stress is removed. Strain which persists after the stress that produced it is removed is called permanent set. For brevity it is convenient to speak of strain which disappears when the stress is removed as elastic strain.

Actual materials are in general nearly perfectly elastic with regard to small stresses, and very imperfectly elastic with regard to great stresses. In most materials, if the applied stress is less than a certain limit, the strain is small in amount, and disappears wholly or almost wholly when the stress is removed. If the applied stress exceeds this limit, the strain is, in general, much greater than before, and the chief part is found, when the stress is removed, to consist of permanent set. The limits of stress within which strain is wholly or almost wholly elastic are called elastic limits or limits of elasticity.

For any particular mode of stress the limit of elasticity is much more sharply defined in some materials than in others. When well defined it may readily be recognised in the testing of a sample from the fact that after the stress exceeds the limit of elasticity the strain begins to increase in a much more rapid ratio to the stress than before. This characteristic goes along with the one already mentioned, that up to the limit the strain is wholly or almost wholly elastic.

16. Hooke's Law. Within the limits of elasticity the strain produced by a stress of any one kind is proportional to the stress producing it. This relation between elastic strain and stress was enunciated by Hooke in 1676, and is known as Hooke's Law.

In applying Hooke's Law to the case of simple longitudinal stress,—such as the case of a bar stretched by simple longitudinal pull,—we may measure the state of strain by the change of length per unit of original length which the bar undergoes when stressed. Let the original length be l and let the whole change of length be δl when a stress is applied whose intensity p is within the elastic limit. Then the strain is measured by $\frac{\delta l}{l}$, and this by Hooke's Law is proportional to the intensity of the pull p .

Thus
$$\frac{\delta l}{l} \propto p,$$

which may be written

$$\frac{\delta l}{l} = \frac{p}{E},$$

where E is an appropriate constant depending on the particular material dealt with. The same value of E applies in push as in pull, these two stresses being essentially of the same kind and only differing in sign. The longitudinal extension per unit of length, or $\frac{\delta l}{l}$, may be conveniently expressed by a single symbol e .

$$e = \frac{\delta l}{l} = \frac{p}{E}.$$

The constant E may be defined as the ratio of the intensity of stress to the longitudinal strain:—

$$E = \frac{p}{e}.$$

17. Young's Modulus or the Stretch Modulus. This constant E is called Young's modulus, the modulus of longitudinal extensibility, or more briefly the stretch modulus. Its value, which is expressed in the same units as are used to express intensity of stress, may be measured directly by exposing a long sample of the material to longitudinal pull and noting the extension, or indirectly by measuring the flexure of a loaded beam of the material, or by experiments on the frequency of vibrations. Practical methods of making such measurements will be described in a later chapter. It is frequently spoken of by engineers simply as the modulus of elasticity, but this name is too general, as there are other modulus which relate to other modes of stress.

In iron and steel the value of Young's modulus is about 13000 tons per square inch; in other words, a stress of 1 ton per square inch produces an extension which is $\frac{1}{13000}$ of the original length. This will serve to illustrate the important fact that the elastic strains which occur in engineering structures are very small quantities. A strain amounting to as much as one part in a thousand would be exceptionally large. To produce this would require in steel a stress of 13 tons per square inch, and the stresses which are permitted in structures have rarely more than about half this intensity.

18. Ratio of Lateral Contraction to Longitudinal Extension in Simple Pull. In a stress of simple pull or push the width and thickness of the piece change by amounts which bear (for strain within the elastic limit) a definite proportion to the longitudinal strain. If the stretch per unit of length in an elastic strain is e the transverse contraction per unit of the width is

$$\frac{e}{\sigma} = \frac{\rho}{\sigma E},$$

where σ is a coefficient to be determined by experiment. Its value in metals is generally between 3 and 4. The ratio of lateral contraction to longitudinal extension in elastic strains, or $\frac{1}{\sigma}$, is often called Poisson's Ratio.

When a pull is applied which exceeds the elastic limit, lateral contraction still accompanies the longitudinal extension but its

proportion is no longer the same as that which holds for elastic strain. All that has been said here about the lateral contraction produced by a stress of simple pull applies also to the lateral expansion produced by a stress of simple push.

19. Strain produced by Shearing Stress. Modulus of Rigidity or Shear Modulus. When the state of stress is one of simple shear (§ 11) the material is distorted so that an element originally cubical becomes lengthened in one diagonal direction, and shortened to an equal extent in the other, its sides remaining parallel. There is no change of volume in this distortion.

The square side $ABCD$ (fig. 8) takes the form indicated by the dotted lines, its angles changing by a

small quantity ϕ to the values $\frac{\pi}{2} + \phi$ and

$\frac{\pi}{2} - \phi$. This change of angle expressed in

circular measure serves as a measure of the strain: it is called the Angle of Shear. Since Hooke's Law holds good (within the elastic limit) for shear as well as for other strains, ϕ is proportional to the intensity q of the shearing stress. It may therefore be written

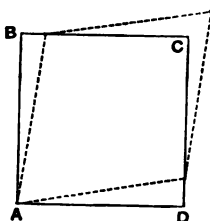

Fig. 8.

$$\phi = \frac{q}{C},$$

where C is a constant for the particular material, expressing its elastic resistance to shearing strain. C is called the *Modulus of Rigidity*. It is stated numerically in the same units as are used to specify the stress. The value of C is most often determined by experiments on torsion, and it is generally found to be about two-fifths that of Young's modulus E . C may be defined as the ratio of shearing stress to shearing strain, or $\frac{q}{\phi}$.

20. Modulus of Cubic Compressibility or Bulk Modulus.

When three simple stresses of equal intensity p and of the same sign (all pulls or all pushes) are applied in three directions, the material (provided it have the same elastic properties in all directions) suffers change of volume only, without distortion

of form. If the volume is V and the change of volume is δV , the fraction $\frac{\delta V}{V}$ measures the strain. The ratio of the stress p to the strain $\frac{\delta V}{V}$ for elastic changes of bulk is called the modulus of cubic compressibility or bulk modulus and may be denoted by K .

$$\frac{\delta V}{V} = \frac{p}{K}.$$

In this strain the linear dimensions of the body all change equally, and (assuming the cubic strain to be small) the amount of the linear strain in any direction is one-third of the cubic strain or

$$\frac{p}{3K}.$$

The modulus K may be directly measured by observing the contraction of volume which a body undergoes when immersed in a liquid to which pressure is applied, but its value is more usually inferred from a knowledge of the other elastic constants.

21. Relation between the Modulus of Elasticity. The four elastic constants which have now been defined, namely, E , C , K , and σ , are related in this way that if any two of them are known by experiment the other two may be calculated, provided the material has the same elastic properties in all directions. Materials which have the same properties in all directions are called isotropic. In isotropic materials two of these constants are sufficient to specify the elastic properties, and equations may be formed connecting any three of the constants with one another. The relations which exist between the various elastic constants will be discussed in the next chapter.

22. Work done in producing an Elastic Strain: Resilience. When a material which follows Hooke's Law is strained the stress must increase in proportion to the strain, and the mean value of the stress is half the final value. The work done is measured by the product of the strain into the mean value of the stress. Consider a tie-rod or other piece subjected to simple pull, of intensity p . The strain e , per unit of length, is $\frac{p}{E}$. This extension is produced, in each filament of unit sectional area, by the application of a force p and the mean force during the

extension is $\frac{1}{2}p$. Hence the work done, per unit length of such a filament, or in other words, per unit of volume of the material, is

$$\frac{p^2}{2E}.$$

Since the material is, by supposition, elastic, this expression also measures the energy stored in the piece, per unit of volume, in consequence of the strain and capable of being restored when the strain is relaxed. It is called the *resilience* of the piece.

In the same way $\frac{q^2}{2C}$ measures the work stored, per unit of volume, in a material subjected to elastic shear by a shearing stress of intensity q . This may readily be seen by considering the distortion of a block like that of fig. 8. The forces on the opposite sides of the block form a couple, and the work done is half the product of the angle of shear into the moment of the couple. By taking a block each of whose sides has unit length, the above expression for the resilience in a shear is at once obtained.

CHAPTER II.

RELATIONS BETWEEN THE ELASTIC CONSTANTS.

23. Relation between E , C , and K in Isotropic Materials. To find a relation between Young's modulus E , the modulus of rigidity C , and the modulus of cubic compressibility K , the following artifice is convenient. Suppose a stress of simple pull to be applied to a body and consider a cubical element two of whose faces are perpendicular to the direction AB of the applied stress. The applied stress p which acts on the top and bottom faces of the cube may be broken up into three parts each equal to $\frac{1}{3}p$. Further, it will not affect the actual state of stress if we suppose a pull stress of intensity $\frac{1}{3}p$ and also a push stress of the same intensity to be applied to each of the other two pairs of faces. We thus obtain the group of stresses indicated by arrows in the figure (fig. 9). Now the push of $\frac{1}{3}p$ on the front and back faces ah and bg together with one of the pulls of $\frac{1}{3}p$ on the top and bottom makes up a state of simple shear the intensity of which is $\frac{1}{3}p$. Again, the push of $\frac{1}{3}p$ on the two sides af and dg together with another of the pulls of $\frac{1}{3}p$ on the top and bottom makes up another simple shear, at right angles to the first, and also of intensity $\frac{1}{3}p$. What is left is a pull of $\frac{1}{3}p$ on every one of the six faces, that is to say, a stress producing cubic dilatation.

Thus a simple pull of intensity p is found to be equivalent to two shears each of $\frac{1}{3}p$, the directions of which are at right angles to each other and are inclined at 45° to the axis of the pull, together with a cubic dilating stress which also has the intensity $\frac{1}{3}p$.

Next we have to find the total change of length which the

block undergoes along the axis AB in consequence of the stresses due to these two shears and to the cubic dilating stress. Here, and throughout this chapter, we shall assume that the material may be treated as isotropic in respect of elasticity.

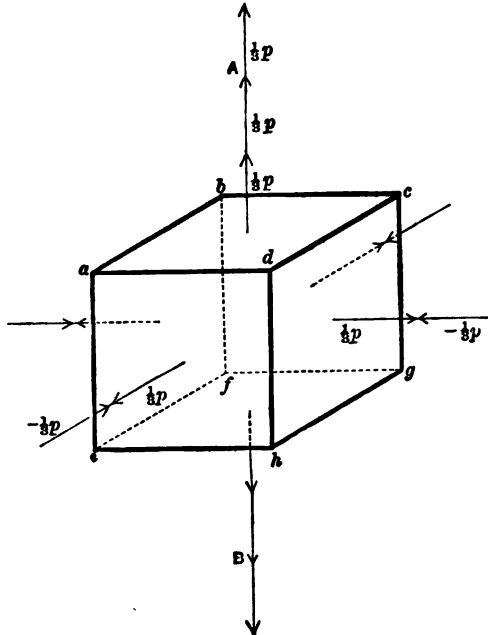

Fig. 9.

Each of the two shears causes an extension $\frac{\delta a}{a}$ in the direction AB , where a is the diagonal of an element such as that sketched in fig. 10 and δa is the extension of the diagonal caused by the shear. But $\frac{\delta a}{a} = \frac{\delta b}{b}$ (see the figure) and is therefore equal to $\frac{1}{2}\phi$.

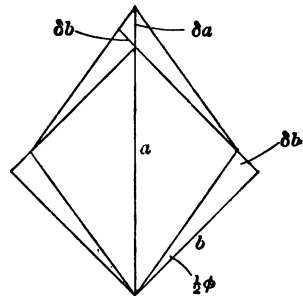

Fig. 10.

Further, $\phi = \frac{1/2 p}{C}$, since $1/2 p$ is the intensity of the shearing stress.

Hence each of the shearing stresses extends the piece in the direction AB by the amount (per unit of length)

$$\frac{1/2 p}{C}.$$

4

Again, the cubic dilating stress $\frac{1}{3}p$ extends every dimension by the amount (per unit of length)

$$\frac{\frac{1}{3}p}{K}.$$

Thus the whole strain in the direction AB is equal to

$$2 \times \frac{\frac{1}{3}p}{C} + \frac{\frac{1}{3}p}{K} = p \left(\frac{1}{3C} + \frac{1}{9K} \right),$$

due to the two shears and the cubic dilating stress, which we have seen to be equivalent to the simple pull p .

But the strain along AB due to a simple pull p is directly expressed as

$$\frac{p}{E}.$$

Hence $\frac{p}{E} = p \left(\frac{1}{3C} + \frac{1}{9K} \right)$, from which

$$E = \frac{9KC}{3K + C}.$$

24. Relation of σ to the moduluses C and K . Consider next the change in transverse dimensions due to the shears and the cubic dilatation into which we have analyzed the strain. Each transverse dimension is affected by one of the two shears. The shear contracts it to the extent $\frac{p}{6C}$ and the cubic dilatation enlarges it to the extent $\frac{p}{9K}$.

Hence the resultant lateral contraction, perpendicular to the direction AB of the applied stress p , is

$$\frac{p}{6C} - \frac{p}{9K},$$

and σ , the ratio of the longitudinal extension to the lateral contraction, is given by the equation

$$\sigma = \frac{\frac{1}{3C} + \frac{1}{9K}}{\frac{1}{6C} - \frac{1}{9K}} = \frac{6K + 2C}{3K - 2C}.$$

It follows from this that σ is always greater than 2, since C is necessarily positive. It will be only slightly greater than 2 in substances which have K great in comparison with C . An instance in point is furnished by india-rubber, where the elastic resistance

to change of volume is great and the resistance to shearing is small. India-rubber is distorted with ease but compressed (cubically) with great difficulty, and consequently the value of σ in it is much greater than 2.

The fractional expansion of volume which a body undergoes in the elastic strain caused by a simple pull along one axis is equal to the longitudinal strain multiplied by $1 - \frac{2}{\sigma}$, since for every unit by which the length of a cubical element increases the breadth and thickness each diminish by $\frac{1}{\sigma}$. No change of volume would result if σ were equal to 2.

25. Other expressions of relation between the Elastic Constants. The equations given above are sufficient to establish a connection between any three of the four elastic constants. It may, however, be useful to indicate other ways in which these relations may be found and other forms in which they may be expressed.

Consider for example a simple shear of intensity p . The linear extension and contraction respectively in two directions inclined at 45° to the plane of shear are $\frac{\phi}{2}$ or $\frac{p}{2C}$. We may regard the shear as made up of two principal stresses, one of push and one of pull, along these two directions, each having the same intensity as the given shearing stress. The strain in either direction is

$$\frac{p}{E} + \frac{p}{\sigma E},$$

the first term representing the direct effect of the one principal stress and the second term representing the lateral effect of the other.

$$\text{Hence} \quad \frac{1}{2C} = \frac{1}{E} + \frac{1}{\sigma E},$$

$$\text{or} \quad E = 2C \left(1 + \frac{1}{\sigma} \right),$$

$$\text{and} \quad C = \frac{\sigma E}{2(\sigma + 1)}.$$

This equation may of course be obtained also by eliminating K in the results of §§ 23 and 24.

It may be concluded from this that C is always less than $\frac{E}{2}$. Further, since σ is not less than 2, the factor $\left(1 + \frac{1}{\sigma}\right)$ cannot exceed $\frac{3}{2}$. Hence E has in all cases a value lying between $2C$ and $3C$. In metals σ is usually about $3\frac{1}{2}$, which makes E about $2.6C$.

Again, consider a piece under "fluid" stress, namely with three equal principal stresses all of the same sign. The linear strain in any direction is made up of one direct and two lateral strains and has the value

$$\frac{p}{E} - \frac{p}{\sigma E} - \frac{p}{\sigma E} = \frac{p}{E} \left(1 - \frac{2}{\sigma}\right).$$

Hence the volume strain, being three times the linear strain, is

$$\frac{3p}{E} \left(1 - \frac{2}{\sigma}\right).$$

But the volume strain may also be expressed as $\frac{p}{K}$, whence

$$\frac{1}{K} = \frac{3}{E} \left(1 - \frac{2}{\sigma}\right),$$

or

$$E = 3K \left(1 - \frac{2}{\sigma}\right),$$

and

$$K = \frac{\sigma E}{3(\sigma - 2)}.$$

Combining this with the equation given above connecting C and E with σ , and eliminating E , we have

$$\sigma = \frac{2(3K + C)}{3K - 2C},$$

or, eliminating σ ,

$$E = \frac{9CK}{3K + C}.$$

These are identical with the results obtained more directly by another method in §§ 23 and 24.

26. Equations connecting Stresses and Strains. Suppose an isotropic material to be in a state of stress of the most general kind, and let the three principal stresses be p_x , p_y , and p_z , the axes of reference being chosen so that they coincide with the principal axes. Let the strains along these axes be e_x , e_y and e_z respectively. Then e_x is made up partly of the direct strain which p_x produces

in its own direction, and partly of the lateral strains produced by p_y and p_z . The direct strain due to p_x is $\frac{p_x}{E}$ and the lateral strains are $\frac{-p_y}{\sigma E}$ and $\frac{-p_z}{\sigma E}$.

Thus
$$e_x = \frac{p_x}{E} - \frac{p_y + p_z}{\sigma E},$$

or
$$Ee_x = p_x - \frac{p_y + p_z}{\sigma}.$$

Similarly
$$Ee_y = p_y - \frac{p_x + p_z}{\sigma},$$

and
$$Ee_z = p_z - \frac{p_x + p_y}{\sigma}.$$

We proceed to apply these general equations to particular cases.

27. State of Simple Shear. The state of stress is one of simple shear when $p_y = -p_x$ and $p_z = 0$. In that case the equations become

$$Ee_x = p_x + \frac{p_x}{\sigma} = p_x \left(1 + \frac{1}{\sigma}\right),$$

$$Ee_y = -p_x - \frac{p_x}{\sigma} = -p_x \left(1 + \frac{1}{\sigma}\right),$$

$$Ee_z = 0.$$

We have seen (§ 23) that the strain along each axis of principal stress is equal to $\frac{1}{2}\phi$ where ϕ is the angle of shear.

Hence
$$\phi = 2e_x = \frac{2p_x \left(1 + \frac{1}{\sigma}\right)}{E},$$

and since the intensity of the shearing stress is numerically equal to p_x or p_y , this leads, as before, to the equation

$$E = 2C \left(1 + \frac{1}{\sigma}\right).$$

28. Volume Strain. By adding the three general equations we have

$$E(e_x + e_y + e_z) = (p_x + p_y + p_z) \left(1 - \frac{2}{\sigma}\right),$$

or
$$E \frac{\delta V}{V} = (p_x + p_y + p_z) \left(1 - \frac{2}{\sigma}\right).$$

In the particular case when $p_x = p_y = p_z$ (the case which occurs in a fluid)

$$E \frac{\delta V}{V} = 3p \left(1 - \frac{2}{\sigma} \right),$$

which gives the relation already found in § 25

$$E = \frac{3K(\sigma - 2)}{\sigma}.$$

29. Simple Strain along one axis. The student will notice that a simple strain, in the sense of a strain along one axis only, is not produced by the application of a simple stress. To restrict the strain to e_x , making e_y and e_z vanish, we have to apply certain stresses p_y and p_z as well as a stress p_x . The equations become in that case

$$Ee_x = p_x - \frac{p_y + p_z}{\sigma},$$

$$0 = p_y - \frac{p_x + p_z}{\sigma},$$

$$0 = p_z - \frac{p_x + p_y}{\sigma}.$$

Hence $p_y = p_z = \frac{p_x}{\sigma - 1}$, showing that a simple contraction without lateral expansion is produced when a direct compressive stress is associated with two equal lateral stresses, also of compression, each of which is less than the direct stress in the ratio $1 : \sigma - 1$.

The relation which then holds between the strain e_x and the stress p_x is given by the equation

$$Ee_x = p_x \left(1 - \frac{2}{\sigma(\sigma - 1)} \right) = p_x \frac{(\sigma - 2)(\sigma + 1)}{\sigma(\sigma - 1)}.$$

Hence
$$\frac{p_x}{e_x} = \frac{E\sigma(\sigma - 1)}{(\sigma - 2)(\sigma + 1)},$$

and this constant may be called the modulus of elasticity for the special mode of stress here assumed. Under this mode of stress the strain e_x is less than that which would be produced by p_x , acting alone, in the ratio of $\sigma^2 - \sigma - 2$ to $\sigma^2 - \sigma$.

30. Lateral Strain prevented in one direction. A case presenting more practical interest is found when a piece, pulled or pushed along one axis (OX), is left free to contract or expand

along one lateral axis (OY) but is prevented from changing its dimension along the other lateral axis (OZ). In that case e_x and p_y are zero and we have

$$Ee_x = p_x - \frac{p_z}{\sigma}.$$

$$Ee_y = -\frac{p_z + \nu p_x}{\sigma},$$

$$0 = p_z - \frac{\nu p_x}{\sigma}.$$

Hence the required lateral stress p_z is of the same sign as p_x and is equal to $\frac{\nu p_x}{\sigma}$, and

$$Ee_x = p_x \left(1 - \frac{\nu}{\sigma^2}\right).$$

Thus the special modulus of elasticity for this mode of stress is

$$\frac{p_x}{e_x} = \frac{E\sigma^2}{\sigma^2 - \nu},$$

and the strain e_x is less than p_x acting alone would produce, in the ratio of $\sigma^2 - \nu$ to σ^2 .

31. Numerical Example. The elastic constants which are most usually measured are Young's modulus E and the modulus of rigidity C . In a later chapter experiments will be described by which such measurements are made. With steel, the modulus E is about 13000 tons per square inch and C is about 5000 tons per square inch. Taking these values we may determine corresponding values of the other constants, thus—

$$K = \frac{EC}{9C - 3E} = 10830 \text{ tons per square inch,}$$

$$\sigma = \frac{2C}{E - 2C} = 3\frac{1}{3}.$$

The modulus for a strain in which lateral contraction or expansion is entirely prevented, or $\frac{E\sigma(\sigma - 1)}{(\sigma - 2)(\sigma + 1)}$, is 17500 tons per square inch, and the modulus for a strain in which lateral contraction is free to take place in one direction but prevented in the other, or $\frac{E\sigma^2}{\sigma^2 - 1}$, is 14290 tons per square inch.

CHAPTER III.

ULTIMATE STRENGTH AND NON-ELASTIC STRAIN.

32. Strain carried beyond the Limit of Elasticity. All that has been said about the elastic constants refers only to the strains which occur when the stresses are so small as to fall within the limits of elasticity. Within these limits we may without serious inaccuracy take the strain as being proportional to the stress and as disappearing when the stress is removed. Strictly speaking, absolute proportionality of strain to stress is never found, and probably there is no stress, however small, that does not produce some permanent effect. There is always some slight *hysteresis* or lagging in the relation of strain to stress, which shows itself for example when a tie-bar is alternately loaded and unloaded, the length under any intermediate amount of load being a very little greater during unloading than during loading. But in general this imperfection in elasticity is so slight that it may safely be disregarded when we are dealing with the strains caused by comparatively small amounts of stress, and up to a certain limit, which is in general pretty well defined, Hooke's Law may be taken as substantially accurate.

When that limit is reached a change takes place in the relation of strain to stress which exhibits itself in three ways. As the loading proceeds the increments of strain, for equal increments of stress, become greater. Further it is observed that the amount of strain due to any given load depends to some extent on the time during which the load acts. When a load exceeding the elastic limit is applied the strain which occurs at once is followed by a continued "creeping" or supplementary deformation which is very noticeable during the first few minutes and may go on, though at a diminished rate, for a much longer time. Lastly, when the load is removed some permanent set is found.

We shall call a piece *overstrained* when the stress exceeds the elastic limit. The overstrained piece is more or less plastic. A stress which produces overstraining requires a long time (possibly an indefinitely long time) to produce its full effect. As the load is further increased this plasticity becomes in general more and more marked. The material in some cases flows under the applied stress like a viscous liquid and time is the main factor in determining the amount of the strain. The behaviour of iron, mild steel, and most other metals when tested for tensile strength, exemplifies this. When the load exceeds the elastic limit a certain amount of "creeping" or continued extension is observed whenever the process of loading is temporarily suspended. And a stage is reached at which, without further increase of load, the piece continues to draw out until it breaks.

33. Ultimate Strength. The load which suffices to cause rupture measures the ultimate strength of the piece. In reckoning the ultimate strength of a material in tons or pounds per square inch the practice of engineers is to take, not the actual intensity of stress at the time when the piece breaks, but the value which this intensity would have reached had the original area of section remained unchanged. In other words, the ultimate strength is reckoned as the breaking load per square inch of the original area of section, not per square inch of the area which the section has when the piece breaks. Thus if a bar whose original cross-section is 2 square inches be broken by applying a total pull of 60 tons, uniformly distributed over the section, the ultimate tensile strength of the material is said to be 30 tons per square inch, although the actual intensity of stress in the last stages of the test may have been much greater than this in consequence of the contraction which the section undergoes before the piece breaks, especially in the neighbourhood where the break is to occur.

The reason for this usage is that engineers wish in all cases to know what total load will break a piece, in order that they may arrange to prevent the actual load from being more than a safe fraction of that. Suppose for instance that a tie-rod is to be designed to bear safely a pull of 12 tons, and that the working load is to be only one-fifth of the load which would break the rod. It must in that case have such an area of section as would

be broken by a load of 5×12 or 60 tons. Hence if the material has an ultimate strength of 30 tons per square inch, the proper area of section is at once seen to be $\frac{60}{30}$ or 2 square inches. Or, to put the same thing in a slightly different way, the working load is to be one-fifth of 30, or 6 tons per square inch, and the section is accordingly $\frac{6}{30}$ or 2 square inches. Such a calculation proceeds on the basis of the ultimate strength as defined by reference to the original area of section of a test-piece, and has nothing to do with the changes of section which occur during the process of testing. It may be added that the working loads on the parts of engineering structures are, or ought to be, in all cases within the limits of elasticity, and within these limits the change of cross-section caused by the elastic strains is so small that it may be neglected in calculating the intensity of stress.

Ultimate tensile strength and ultimate shearing strength are well defined, since in the corresponding modes of stress, namely simple pull and simple shear, a distinct fracture is observed when the stress is sufficiently increased. Under compression, on the other hand, some materials yield so continuously that their ultimate strength to resist compression can scarcely be specified: it would for instance be difficult to assign any value to the compressive strength of such a substance as lead, for a test-piece under compression would flatten out almost without limit. Some materials, notably brick and stone as well as the more brittle metals, show so distinct a fracture by crushing that their compressive strength may be specified with fair precision.

Some of the materials used in engineering are so far from being isotropic that their strength is widely different for stresses in different directions. The tensile strength of timber, for example, is immensely greater when pull is applied along the fibre than when pull is applied across the fibre, and a similar difference exists in regard to the shearing strength. In wrought-iron the process of rolling develops something of a fibrous structure, partly in consequence of the presence of streaks of slag which become drawn out into long lines as the bar or plate is rolled. The tensile strength of a rolled iron plate is accordingly found to be considerably greater in the direction of rolling than across the plate. Steel plates, being rolled from a nearly homogeneous ingot, are more nearly isotropic, but even in them some difference of the same kind is observed.

34. Factor of Safety. In applying a knowledge of the ultimate strength of materials to determine the proper sizes of parts in an engineering structure the designer has to select a maximum value for the stress that is to be allowed. The working stress, as we may for brevity call the stress which will occur in the loaded structure, has to be no more than a certain fraction of the ultimate strength, and what this fraction should be is a matter for the judgment of the engineer. The ratio

$$\frac{\text{ultimate strength}}{\text{working stress}}$$

is called the *factor of safety*.

The choice of a factor of safety depends on many considerations, such as the probable accuracy of the estimated loads and also that of the theory on which the calculation of the working stress has been based; the uniformity of the material dealt with, and the extent to which its strength may be expected to conform to the assumed value or to the values determined by experiments on samples; the possible effects of bad workmanship in causing a deviation from the specified dimensions when the structure is actually built; the degree to which the materials may be expected to deteriorate in time or by exposure to variations of temperature. Another important consideration in the choice of the factor of safety is the variability or uniformity of the load: for reasons which will appear presently a larger factor is properly chosen when the load is subject to repeated changes. When the loads are such as to cause alternations of stress from tension to compression it is especially important that the working stress should not even approach the elastic limit of the material. The factor of safety also serves to provide for the incidental shocks which may occur in consequence of sudden variations in the load. Such shocks cause supplementary stresses which can scarcely be made subjects of calculation.

The factor of safety is rarely less than 3, it is very commonly 4 or 5, and it is sometimes as much (in machines) as 10 or 12. A Board of Trade rule permits the working stress in bridges and other structures of wrought-iron to be 5 tons per square inch. As the tensile strength of the material is in this case about 20 tons per square inch, the rule corresponds to a factor of safety of about 4. A committee of engineers reporting to the British

Association in 1887* recommends that in small bridges, where the permanent load due to the weight of the structure is small compared with the variable load due to traffic, the working stress should not exceed 4 tons per square inch, but that in the case of bridges or other structures of such magnitude that the dead weight is more than twice the moving load the working stress may safely be increased to nearly 6 tons per square inch. These numbers correspond to factors of safety of about 5 and $3\frac{1}{2}$ respectively. In the design of the Forth Bridge, where steel was employed having a tensile strength of from 30 to 33 tons per square inch, the working stress was allowed to reach $7\frac{1}{2}$ tons per square inch, but in members liable to alternate compression and extension it was restricted to 5 tons per square inch.

The selection of a suitable factor of safety and the use of a limit of working stress in determining the dimensions of the several parts of a structure results in not only making all parts sufficiently strong, but in preventing waste of material locally by making the margin of strength equal for all parts.

35. Variation of the Ultimate Strength under different modes of loading. In specifications of ultimate strength it is generally assumed that the load is made to increase continuously and at a fairly rapid rate until the piece breaks: it is supposed to be applied as it would be applied in ordinary testing. But by following special modes of loading it is possible either to increase or to diminish the ultimate strength very considerably. Instances of this will be detailed later. By adding the load in a series of steps with long pauses between we may cause the piece to bear much more than would suffice to break it if applied in the usual way. On the other hand, if a load be applied and removed many times it will suffice to break the piece even though its amount is much less than would be needed to cause rupture in a single application. A much smaller stress still will cause rupture if it alternates between compression and extension. Hence in a structure which has to bear "live" or variable load the permissible intensity of working stress is less than in a structure which bears only "dead" or constant load.

36. Advantage of Plasticity. From an engineering point of view the structural merit of a material, especially when live loads and possible shocks have to be borne, depends not only on

* *Rep. Brit. Assoc.*, 1887, p. 438.

the ultimate strength but also on the extent to which the material will bear deformation without rupture. Other things being equal, a material which in the later stages of the test exhibits much plasticity, by drawing out much under pull and narrowing its section before it breaks, is to be preferred to one which breaks off short. Accordingly the ultimate elongation and the contraction of area are often specified as well as the ultimate strength. The same characteristic is often tested in other ways, such as by bending and unbending bars in a circle of specified radius, or by examining the effect of repeated blows. This is sometimes done by supporting a piece of the material as a beam and causing a weight to fall on the middle of it from a given height.

37. Ordinary Tensile Tests. The most usual test however is made by applying a direct pull and gradually increasing it until the specimen breaks. When the samples to be tested are small wires the stress may be applied directly by hanging up the wire and applying weight, but when larger sections are to be dealt with some form of *testing machine* is needed to facilitate the application and measurement of the load, and to allow the considerable amount of work to be done which is expended in drawing out the piece beyond the limit of elastic strain.

As the test proceeds the extension is at first so small that it can be measured only by a microscopic or other refined apparatus called an *extensometer*. Presently the elastic limit is passed: the increments of strain then become greater and the phenomenon of creeping begins to be observed. In plastic metals such as wrought-iron and steel a further change happens when the load is increased to a somewhat higher value than the elastic limit. A point called (by Professor Kennedy) the *yield point* is reached at which the specimen draws out suddenly, the sudden increase of extension being generally greater than the whole amount of the extension caused by smaller loads. At this stage, and during the remainder of the test, the extension is usually so great that a pair of compasses and a foot-rule serve to measure it. After the yield point is passed, the piece continues to extend more or less irregularly under augmented loads until rupture is about to take place. At that stage there is a supplementary local yielding—the portion in the neighbourhood of the place where fracture is to occur

draws out much more rapidly than the rest of the bar, and the section there becomes attenuated.

38. Diagrams of Extension and Loads in Tensile Tests.

The chief results of a tensile test are conveniently exhibited by drawing a diagram to show the relation of the extension to the load (reckoned per square inch of the original area of section of the specimen). Typical diagrams for wrought-iron, mild steel, and comparatively hard steel are given in fig. 11, the data for which are taken from tests by the late Mr David Kirkaldy*. Up

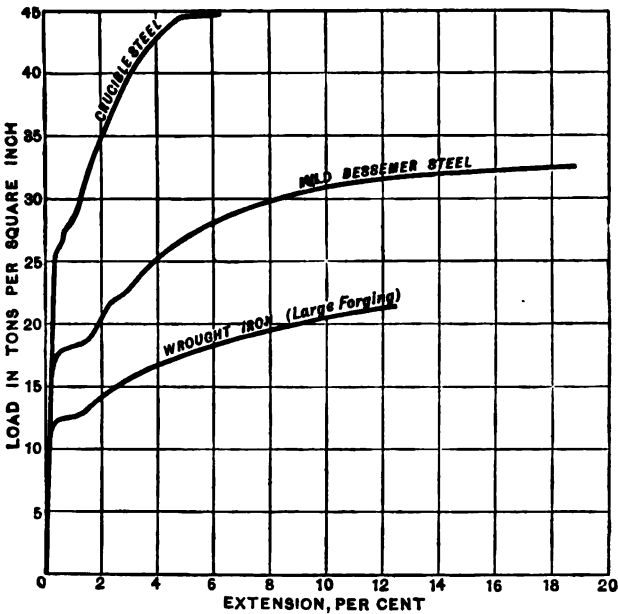

Fig. 11.

to the elastic limit the extension per ton of load is much the same in all three materials, so that the early portions of the three curves are indistinguishable. In each case there is a visible defect of elasticity some way before the yield point is reached, and then a well-marked yield point, especially in the softer metals, at which extension goes on for a time through a considerable distance without increase of load. After this the extension becomes less rapid

* *Experiments on the Mechanical Properties of Steel by a Committee of Engineers*; London, 1868 and 1870.

until the final yielding occurs just before rupture. In the last stages the flow of the metal continues even if the load be somewhat reduced, and it is therefore possible to make the end of the curve bend back by taking off part of the load as the end of the test is approached.

By way of contrast with the diagrams of extension and load in plastic metals, shown in fig. 11, reference should be made to fig. 12,

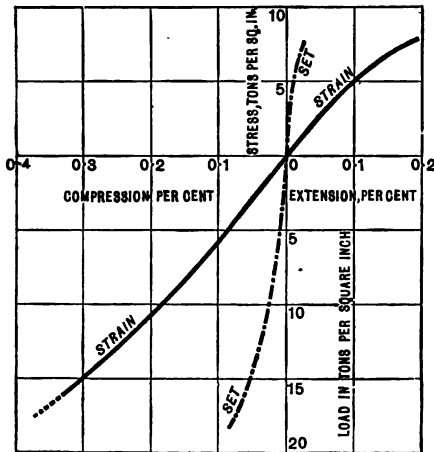

Fig. 12.

which shows how cast-iron behaves under compression as well as under tension. The figure is taken from one of Hodgkinson's experiments*.

The extension was measured on a rod 50 feet long; the compression was also measured on a long rod, which was prevented from buckling by being supported in a trough with partitions. The full line gives the strain produced by loading; it is continuous through the origin, showing that Young's modulus is the same for pull and push—a result which is also found to hold good in other load materials. The broken line shows the set produced by each load. Hodgkinson found that in cast-iron some set could be detected after even the smallest loads had been applied. This is probably due to the existence of initial internal stress in the metal, produced by unequally rapid cooling in

* Report of the Commissioners on the Application of Iron to Railway Structures, 1849.

different portions of the cast bar. A second loading of the same piece showed a much closer approach to perfect elasticity. The elastic limit is, at the best, ill defined; but by the time the ultimate load is reached the set has become a more considerable part of the whole strain. The pull curves in the diagram extend to the point of rupture; the compression curves are drawn only up to a stage at which the bar buckled between the partitions so much as to affect the results.

39. Autographic Diagrams of Extension and Load.

Testing machines are frequently fitted with recording appliances for automatically drawing diagrams showing the relation of the extension to the load. When the load is measured by a weight travelling on a steelyard, the diagram may be drawn by connecting the weight with a drum by means of a wire or cord, so that the drum is made to revolve through angles proportional to the travel of the weight. At the same time another cord, fastened to a clip near one end of the specimen, and passing over a pulley near the other end, draws a pencil through distances proportional to the strain, and so traces a diagram of stress and strain on a sheet of paper stretched round the drum.

Apparatus of this kind is serviceable in showing the behaviour of plastic materials after the elastic limit has been passed. Effects of viscosity can be traced by noticing the changes in the form of the curve when pauses are made during the application of the load. The full strain corresponding to a given load is reached only after a perceptible time, probably a long time. If the load be increased to a value exceeding the elastic limit, and then kept constant, the metal will be seen to draw out (if the stress be one of pull), at first rapidly and then more slowly. When the applied load is considerably less than the ultimate strength of the piece (as tested in the ordinary way by steady increment of load), it appears that this process of slow extension comes at last to an end. On the other hand, when the applied load is nearly equal to the ultimate strength, the flow of the metal continues until rupture occurs. Then, as in the former case, extension goes on at first quickly, then slowly, but, finally, instead of approaching an asymptotic limit, it quickens again as the piece approaches rupture. The same phenomena are observed in the bending of timber and other materials when in the form of beams. If, instead of being

subjected to a constant load, a test-piece is set in a constant condition of strain, it is found that the stress required to maintain this constant strain gradually decreases.

The gradual flow which goes on under constant stress—approaching a limit if the stress is moderate in amount, and continuing up to fracture if the stress is sufficiently great—will still go on at a diminished rate if the amount of stress be reduced. Thus, in the testing of soft iron or mild steel by a machine in which the stress is applied by hydraulic power, a stage is reached soon after the limit of elasticity is passed at which the metal begins to flow with great rapidity. The pumps often do not keep pace with this, and the result is that, if the lever is to be kept floating, the weight on it must be run back. Under this reduced stress the flow continues, more slowly than before, until presently the pumps recover their lost ground and the increase of stress is resumed. Again, near the point of fracture, the flow again becomes specially rapid; the weight on the lever has again to be run back, and the specimen finally breaks under a diminished load. These features are well shown by fig. 13, which is copied from the autographic diagram of a test of mild steel*.

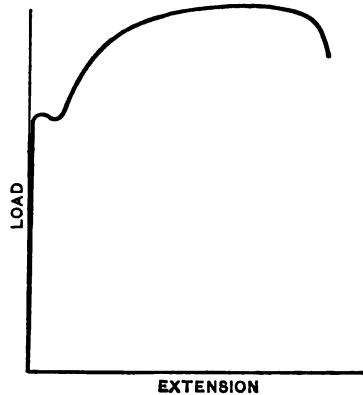

Fig. 13.

40. Hardening effect of rest after overstraining. But it is not only through what we may call the viscosity of materials that the time rate of

loading affects their behaviour under test. In iron and steel, and probably in some other metals, time has another effect of a very remarkable kind. Let the test be carried to any point *a* (fig. 14) past the original limit of elasticity. Let the load then be removed;

* The increase of strain without increase of stress, which goes on without limit when a test-piece under tension approaches rupture, is a special case of the general phenomenon of "flow of solids," which has been exhibited, chiefly for compressive stresses, in a series of beautiful experiments by Tresca (*Mémoires sur l'Écoulement des Corps Solides*, also *Proc. Inst. Mech. Eng.* 1867 and 1878).

during the first stages of this removal the material continues to stretch slightly, as has been explained above. Let the load then be at once replaced and loading continued. It will then be found that there is a new yield-point *b* at or near the value of the load formerly reached; up to this point there is but little strain. The full line *bc* in fig. 14 shows the subsequent behaviour of the piece. But now let the experiment be repeated on another sample, with

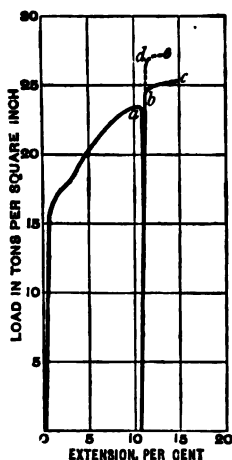

Fig. 14.

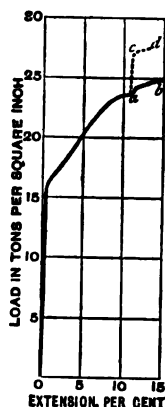

Fig. 14 a.

this difference, that an interval of time, of a few hours or more, is allowed to elapse after the load is removed and before it is replaced. It will then be found that a process of hardening has been going on during this interval of rest; for, when the loading is continued, the new yield-point appears, not at *b* as formerly, but at a higher load *d*. Other evidence that a change has taken place is afforded by the fact that the ultimate extension is reduced and the ultimate strength is increased (*e*, fig. 14).

A similar and even more marked hardening occurs when a load (exceeding the original elastic limit), instead of being removed and replaced, is kept on for a sufficient length of time without change. When loading is resumed a new yield-point is found only after a considerable addition has been made to the load. The result is, as in the former case, to give greater ultimate strength and less ultimate elongation. Fig. 14a exhibits two experiments

of this kind, made with annealed iron wire. A load of $23\frac{1}{2}$ tons per square inch was reached in both cases; *ab* shows the result of continuing to load after an interval of five minutes, and *acd* after an interval of $45\frac{1}{2}$ hours, the stress of $23\frac{1}{2}$ tons being maintained during the interval in both cases*.

41. Breakdown and Recovery of Elasticity after overstraining. Further, a piece of iron or steel which has been overstrained, so that permanent set has been produced, is found to be very imperfectly elastic even with respect to small amounts of load, when, after being removed, the load begins to be reapplied. Hooke's law does not then hold even for loads much below the usual elastic limit of the material. When a small load is applied the immediate strain is seen to be followed by slow creeping, and if the load be removed the strain which it caused does not immediately disappear, but there is a slow creeping back. This is the state of things just after the molecular structure of the piece has been disturbed by overstraining. But if, after a considerable interval of time (such as a few days), the overstrained piece is tested again, a partial recovery of elasticity is found to have taken place, and this recovery becomes more and more complete as time goes on†. The following experiment will serve to show the character of this action, as regards both the immediate effect of overstraining in depriving the material of its usual elasticity and also the subsequent recovery of elasticity with lapse of time. The readings quoted were taken with an extensometer by which the extensions of a nine-inch length in the middle of the specimen were read to the nearest fifty-thousandth of an inch. The zero-reading of the extensometer was 200. The specimen was a turned rod of semi-mild steel, with a diameter of 0.705 inch (section 0.390 sq. inch). In the initial test of the piece, before overstraining, it was found that Hooke's law held with great accuracy up to a load of 10 tons (corresponding to a stress of 25.6 tons per square inch) and that the average extension per ton of load up to

* The experiments of figs. 14 and 14 a are taken from a paper by the author in *Proc. Roy. Soc.* 1880, "On Certain Effects of Stress on Soft Iron Wires," where further experiments bearing on the same point will be found.

† For an investigation of this effect of overstraining, see papers by Bauschinger, *Mitth. aus dem mech.-tech. Lab. in München*, and by the author, *Proc. Roy. Soc.*, vol. 58, 1895.

that point was $85\frac{1}{2}$ of the divisions of the extensometer, corresponding to a value for the modulus E of

$$\frac{1 \times 9 \times 50000}{0.390 \times 85\frac{1}{2}} = 13500 \text{ tons per square inch.}$$

The load was increased to 11 tons, when the yield-point was reached and a permanent extension (of 0.14 inch) took place. Immediately after the overstraining the load was removed, and a series of subsequent tests were made which are detailed in the Table on page 37. In the first of these, (B), made only a few minutes after overstraining had occurred, there is nothing like proportionality of extension to load even with loads of one or two tons, and creeping was observed to occur almost from the first. The later tests (C to H) show a gradual progressive recovery of elasticity, which however is by no means complete even after three weeks.

An experiment of this kind serves to emphasise the distinction between the yield-point and the elastic limit. If the loading of the overstrained piece had been continued a yield-point would have appeared at a load higher than 11 tons, considerably higher after several days of resting. But the elastic limit in this condition, if there can be said to be any limit within which the elasticity is sensibly perfect, is very low—probably not higher than about 2 tons. Immediately after overstraining the piece cannot properly be said to have any elastic limit, but when a period of resting brings about recovery, a more or less definite elastic limit reappears, and rises to higher loads the more prolonged is the period of rest.

In wrought-iron the recovery of elasticity after overstraining takes place much sooner than it does in mild or semi-mild steel. When in the overstrained condition, and before recovery has taken place, iron or steel exhibits much hysteresis in the relation of extension to load. Any process of loading and unloading, repeated until the changes become cyclic, then shows a well-marked difference in the length of the piece for any one amount of load in the two stages of the process. The curves exhibiting extension in relation to load form a loop, and this loop closes up as the piece gradually recovers its elasticity by prolonged rest.

42. Effect of Heating in facilitating Recovery of Elasticity after overstraining. An interesting contribution to this

Successive Loadings of the same Piece, after various Intervals of Time.

Load in tons.	(B.) Ten minutes after overstrain.		(C.) One hour after overstrain.		(D.) One day after overstrain.		(E.) Two days after overstrain.		(F.) Three days after overstrain.		(G.) Five days after overstrain.		(H.) Twenty-one days after overstrain.	
	Extensometer readings.	Differ- ences.	Extensometer readings.	Differ- ences.	Extensometer readings.	Differ- ences.	Extensometer readings.	Differ- ences.	Extensometer readings.	Differ- ences.	Extensometer readings.	Differ- ences.	Extensometer readings.	Differ- ences.
0	200	—	200	—	200	—	200	—	200	—	200	—	200	—
1	287	87	287	87	286	86	286	86	286	86	286	86	285	85
2	377	90	376	89	373	87	372	86	372	86	372	86	371	86
3	469	92	467	91	463	90	461	89	461	89	461	89	458	87
4	565	96	562	95	559	96	556	95	553	92	553	92	545	87
5	662	97	660	98	658	99	653	97	650	97	650	97	632	87
6	760	98	760	100	758	100	754	101	750	100	750	100	720	88
7	866	106	862	102	860	102	857	103	853	103	853	103	810	90
8	976	110	969	107	963	103	960	103	958	105	958	105	900	90
0	208 to 203	—	206 to 200	—	203 to 200	—	203 to 200	—	203 to 200	—	203 to 200	—	200½ to 200	—

subject has been made in experiments conducted in the author's laboratory by Mr James Muir*, who has found that when a piece of iron or steel has had its elasticity broken down by overstraining it will make a very complete recovery if heated for a few minutes to a temperature such as that of boiling water. When the overstrained piece has been immersed in a bath of boiling water it is found to have practically perfect elasticity up to a new yield-point which is higher than the load used in the process of overstraining.

Figs. 15 and 15 a illustrate this by curves drawn from Mr Muir's observations. In the experiments of fig. 15 the

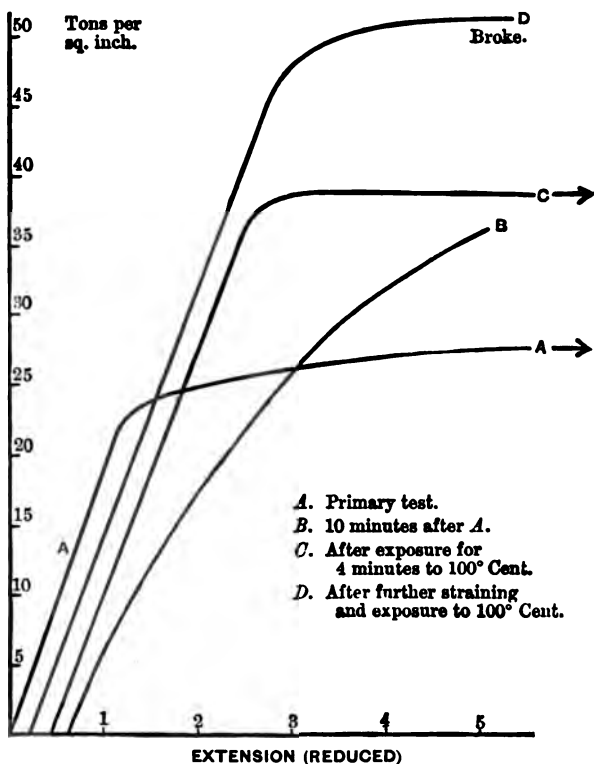

Fig. 15. Semi-mild Steel.

material was a semi-mild steel with 0.4 per cent. of carbon, which when tested in the ordinary way showed a breaking strength of 39 tons per square inch. In fig. 15 a the material was wrought-iron with a breaking strength of 23 tons per square inch. The

* *Phil. Trans. Roy. Soc.*, 1899.

length under measurement was 8 inches in both cases, and the unit of extension in the diagrams is $\frac{1}{100}$ of an inch. In drawing

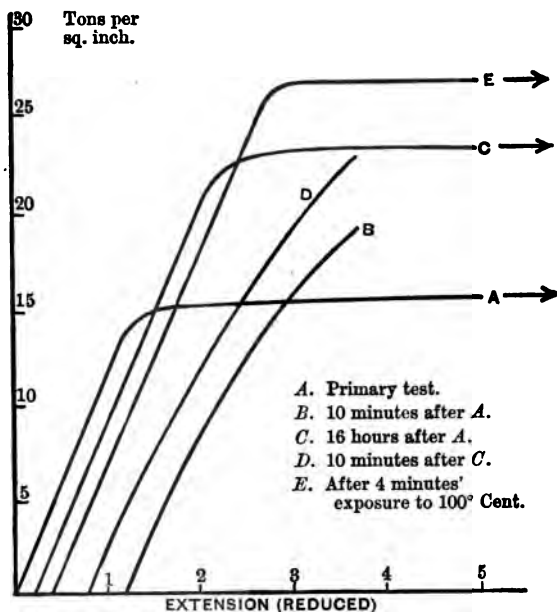

Fig. 15 a. Common Wrought-Iron.

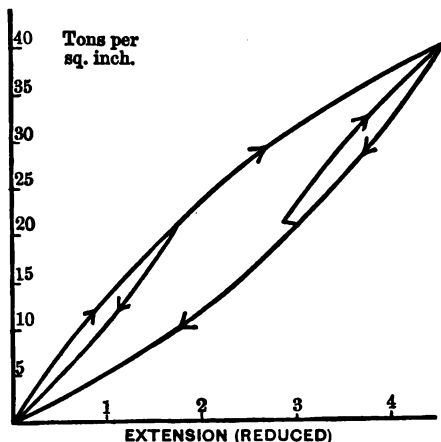

Fig. 15 b. Hysteresis in Semi-mild Steel after overstraining.

these diagrams the geometrical device is used of shearing back the curves uniformly by 1 unit of extension for each 4 tons per square

inch of load. The curves are drawn from separate origins to avoid confusion. In fig. 15 the steel bar in its first loading gave a well-marked elastic limit at about 22 tons, and this primary test was continued (far beyond the limit to which the curve *A* is drawn) until the load was 35 tons per square inch. Curve *B* shows the very imperfect elasticity which the piece exhibited immediately after this overstraining. In other experiments curves of loading and unloading were observed for this condition of the metal, and were found to show the characteristics of hysteresis exemplified in fig. 15 b, where the arrows sufficiently indicate the sequence of the operations. Returning to fig. 15, curve *C* shows the remarkably complete elastic recovery which results from exposure to the temperature of boiling water, and also the raised elastic limit which this treatment produces. Curve *D* shows a further raising of the elastic limit, by additional overstraining (after *C*) followed by a second bath in boiling water.

In fig. 15 a, the first overstraining *A* is seen to produce the non-elastic state *B*, but a rest of 16 hours suffices to restore nearly perfect elasticity, and the next loading gives the curve *C*, with a raised elastic limit. This operation was carried far enough to overstrain the piece a second time, and curve *D* then shows that a very imperfectly elastic condition has reappeared. Finally curve *E* shows the recovery of elasticity brought about by immersion in boiling water. This piece was further overstrained and its elasticity was again restored by hot water, with the result that it finally bore a load of $29\frac{1}{2}$ tons per square inch before breaking.

A remarkable experiment may be made by taking a bar of mild steel and stretching it in the first instance just up to the primitive yield-point, then heating it for a few minutes to 100° C. to produce elastic recovery, then stretching it again just up to its new yield-point, then heating again to 100° C. and so on. Each step raises the elastic limit, and notwithstanding its naturally plastic quality the bar may in this way finally be caused to break with a fracture resembling that of hard steel, with comparatively little total extension or contraction of section at the fracture, and under a total load much greater than that which could be applied in an ordinary test.

In one of Mr Muir's experiments a bar of semi-mild steel showing a strength under ordinary tests of 39 tons per square inch

and an extension of about 20 % on 8 inches was caused to pass through a series of steps of this kind, by being heated to 100° C. just after each successive yield-point was passed. The first yield-point was at 27 tons, the next at 33, the next at 38, the next at 43½, and the last about 47. The piece was then broken, showing a strength of 49½ tons per square inch and a total extension (including all the steps) of 12 per cent.

43. Influence of time in the process of testing. We have seen that intervals of rest, during the process of testing, cause a hardening effect once the primitive elastic limit has been passed, and after any such interval a new yield-point appears at a higher load. By applying the load in a series of steps, with long pauses between, the results of a test may be made to differ very considerably from those that are found in the ordinary process of continuous or nearly continuous and fairly rapid loading. The time during which any load (exceeding elastic limit) is kept on affects the result in two somewhat antagonistic ways. It augments extension by giving the metal leisure to flow. On the other hand it reduces the amount of extension which subsequent greater loads will cause. The stepped curve got by applying the load in parts with long intervals between shows (in iron and steel) a less total elongation and a greater ultimate strength than are found in the ordinary continuous process. An early illustration of this was given in experiments by Mr J. T. Bottomley*. Pieces of iron wire, annealed and of exceptionally soft quality, when loaded at the rate of 1 lb. in 5 minutes broke with 44½ lbs. and stretched 27 per cent. of their original length before breaking. Other pieces of the same wire loaded at the rate of 1 lb. in 24 hours broke with 47 lbs. and stretched less than 7 per cent.

It does not appear that such variations in the rate of loading as are liable to occur in practical tests of iron or steel have much influence on the extension or the strength, great as the effects of time are when the metal is loaded either much more slowly or much more quickly. In fig. 16 the results are shown of tests by the author of two similar pieces of soft iron wire, one loaded to rupture in 4 minutes and the other at a rate about 5000 times slower.

* *Proc. Roy. Soc.*, 1879, p. 221.

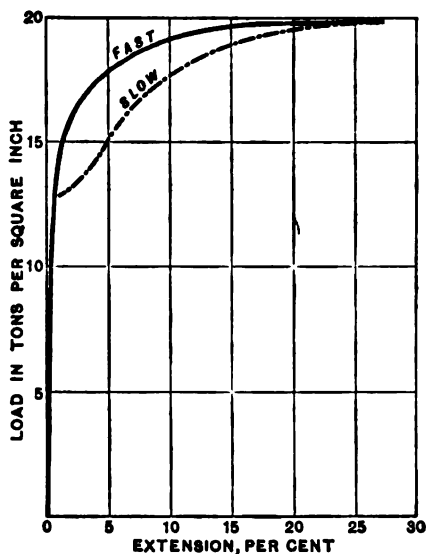

Fig. 16.

44. Effects of Hardening through overstrain. It may be concluded that when a piece of iron or steel (and probably the remark applies to most other metals) has been overstrained in any way—that is to say, when it has received a permanent set by the application of stress exceeding its limit of elasticity—it is hardened, in the sense of being rendered less capable of plastic deformation. Further, after any such overstrain the physical properties of the material go on changing for days or even months—the change being in the direction of greater hardness. Important practical instances of the hardening effect of permanent set occur when plates or bars are rolled cold, hammered cold, or bent cold, or when wire is drawn. When a hole is punched in a plate the material contiguous to the hole is severely distorted by shear, and is so much hardened in consequence that when a strip containing the punched hole is broken by tensile stress the hardened portion, being unable to extend so much as the rest, receives an undue proportion of the stress, and the strip breaks with a smaller load than it would have borne had the stress been uniformly distributed. This bad effect of punching is especially noticeable in thick plates of mild steel. It disappears when a narrow ring of material surrounding the hole is removed by means of a rimer, so that the

material that is left is homogeneous. Another remarkable instance of the same kind of action is seen when a mild-steel plate which is to be tested by bending has a piece cut from its edge by a shearing machine. The result of the shear is that the metal close to the edge is hardened, and, when the plate is bent, this part, being unable to stretch like the rest, starts a crack or a tear which quickly spreads across the plate on account of the fact that in the metal at the end of the crack there is an enormously high local intensity of stress. By the simple expedient of planing off the hardened edge before bending the plate homogeneity is restored, and the plate will then bend without damage. The injurious effect of punching holes in thick plates of iron or steel is now so fully recognised that it is usual to specify that such holes shall be drilled.

45. Annealing. The hardening effect of strain is removed by the process of annealing, that is, by heating to redness and cooling somewhat slowly. The effects of overstraining are got rid of by this treatment, and the material reverts to its primitive state, or may even become more plastic than at first. The temperature in annealing iron or mild steel should not exceed 900° or 1000° C., and it is not necessary or even desirable (see § 59) that the process of cooling should be very slow.

In the ordinary process of manufacture of iron or steel bars and plates by rolling, the metal generally leaves the rolls at so high a temperature that it is virtually annealed, more or less perfectly, and the behaviour of a sample in the commercial state consequently does not differ much from that which the same sample would show if specially annealed*. The case is different with plates and bars that are "cold-rolled" or with pieces that have been hammered while in the cold state; they exhibit the greater strength and much reduced plasticity which result from permanent set. A similar difference is found between wire supplied in the "hard-drawn" state and wire which has had the hardening effect of the last passage through the draw-plate removed by subsequent annealing.

* In several of Mr Kirkaldy's papers a comparison is given of the elastic limit, ultimate strength, and ultimate extension of samples which were annealed before testing, and of samples which were tested in the commercial state; in general the annealed samples are distinctly, though not very materially, softer than the others. (*On the Relative Properties of Wrought-Iron Plates from Essen and Yorkshire*, London, 1876; also *Experiments on Fagersta Steel*, London, 1873.)

When pieces of a structure have been shaped by straining them while cold it is not unusual to anneal them afterwards in order to do away with the hardening effect of the overstrain.

46. Hardening and Tempering of Steel. In wrought-iron, very mild steel, and most other metals the rate of cooling from a red heat in the process of annealing is comparatively unimportant: much the same degree of softness is reached whether the cooling be fast or slow. But a slight difference may be observed with the mildest steel, and with steel containing more than 0·2 per cent. of carbon a marked difference is produced by fast as compared with slow cooling. When heated to bright redness and cooled suddenly, steel containing any considerable proportion of carbon is found to acquire hardness of a different kind from that which is produced by overstraining. A high-carbon steel chilled by plunging it at a cherry-red heat into cold water becomes so hard and brittle as to justify the title "glass-hard," which is sometimes applied to it. It is hard enough to scratch glass, and so brittle that a blow may break it into fragments.

Steel treated in this way loses its plastic character entirely. When tested under tension it breaks with practically nothing but elastic extension, without contraction of section, and shows only a moderate amount of tensile strength.

Further, the glass-hard steel may be deprived of its brittleness, have its strength increased, and have the range of elastic strain greatly extended by subsequent heating to a moderate temperature. This process is called the *tempering* of steel. Its effect depends on the degree to which the temperature of the steel is raised, after it has been hardened. The different grades of temper which are produced in this way are often distinguished by reference to the colour (blue, straw, &c.) which appears on a clean surface during the heating, in consequence of the formation of a film of oxide. Heating the hardened metal to a temperature between 400° F. and 450° F. produces a straw-coloured surface and develops a grade of temper suitable for the points of cutting tools intended to take a keen and hard edge; a temperature of about 550° produces a purple-blue surface and gives a temper suitable for springs, where the desideratum is that the elasticity should be very perfect throughout a wide range of loads. When higher temperatures are used in the process of "letting down" the condition which is reached approaches more nearly to that of the annealed metal.

47. Contraction of section at rupture. The extension which occurs when a bar of uniform section is tested by pull is at first general, and is distributed with some approach to uniformity over the length of the bar. Before the bar breaks, however, a large additional amount of local extension occurs at and near the place of rupture. The material flows in that neighbourhood much more than in other parts of the bar, and the section is much more contracted there than elsewhere. The percentage contraction of area at fracture is frequently stated as one of the results of a test, and is a useful index to the quality of materials. If a flaw is present sufficient to determine the section at which the rupture shall occur, the contraction of area will in general be distinctly diminished as compared with the contraction in a specimen free from flaws, although little reduction may be noted in the total extension of the piece. Local extension and contraction of area are almost absent in cast-iron and hard steel; on the other hand they are specially prominent in wrought-iron, mild steel,

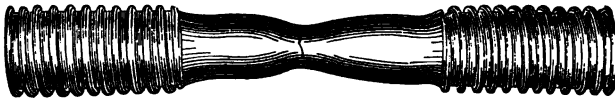

Fig. 17.

and other metals that combine plasticity with high tensile strength. An example is shown in fig. 17, which is copied from a photograph of a broken test-piece of Whitworth soft fluid-compressed steel. The piece was of uniform diameter before the test.

48. Non-elastic Extension. Experiments with long rods show that the general extension which occurs in parts of the bar not near the break is somewhat irregular*; it exhibits here and there incipient local stretching, which has stopped without leading to rupture. This is of course due in the first instance to want of homogeneity. It may be supposed that when local stretching begins at any point in the earlier stages of the test it is checked by the hardening effect of the strain, until finally, under greater load, a stage is reached in which the extension at one place goes on so fast that the hardening effect cannot keep pace with the

* See Kirkaldy's *Experiments on Fagersta Steel*, London, 1873, also *Report of the Steel Committee*, Part 1.

increase in intensity of stress which results from diminution of area; the local extension is then unstable, and rupture ensues. Even at this stage a pause in the loading, and an interval of relief from stress, may harden the locally stretched part enough to make rupture occur somewhere else when the loading is continued.

The molecular disturbance which occurs at the yield-point does not in general set in simultaneously in all parts of a test-piece however uniform the cross-section may be. The author has noticed it begin at one end, while along the greater portion of the length nothing but elastic extension was taking place, and then slowly spread from the place where it began until it included the whole of the piece, the load remaining constant all the while. The breakdown of structure appears to communicate itself gradually from place to place along the bar, each portion becoming in turn unstable when it finds itself deprived of support by the breakdown of neighbouring portions.

49. Crystalline Structure of Metals. Reference should be made in this connection to the results of microscopic examination. When a metal is polished and lightly etched it is seen under the microscope to consist, in general, of crystalline grains, which are crystals with irregular outlines, the form of the boundaries having been determined by the meeting of the grains in their growth. Within each grain there is a definite orientation of the elementary pieces of which the crystal is built up, and the orientation changes from grain to grain. When the metal is stretched by pull, or by cold rolling or cold hammering, the grains become elongated. But when the piece, after the treatment, is heated to redness and is again examined microscopically, the grains are found to have re-formed and to be on the whole as long in one direction as in another. Slow cooling tends to produce large grains and fast cooling produces comparatively small grains.

Microscopic observations by Mr W. Rosenhain and the author* have demonstrated that the manner in which a metal yields when it takes any kind of permanent set is by slips occurring on cleavage or "gliding" surfaces within each of the crystalline grains. These slips show themselves on a polished surface by developing systems

* *Proc. Roy. Soc.*, March 16 and May 18, 1899; *Phil. Trans. Roy. Soc.*, vol. 193, p. 279.

of parallel lines or narrow bands, each of which is a step caused by one portion of the grain slipping over the neighbouring portion. Two, three, and even four systems of slip lines may be traced when the metal is considerably strained. Plasticity results from these slips, although the elementary portions of the crystals retain their primitive form and the crystalline structure of the metal as a whole is preserved. In some metals, in addition to simple slips or motions of pure translation, there is a molecular rotation resulting from strain, which gives rise to the production of "twin" crystals. Apart from this, however, the occurrence of slips on three or more planes within each grain suffices to allow the grain to change its form to any extent as the process of straining proceeds.

50. Percentage of Extension in Tensile Tests. It is usual to measure the extension on a length, generally of 8 inches, in the middle portion of the piece under test, and to express the extension as a percentage of the length. Usually the fracture occurs within the length thus marked off, and when it does so the whole extension which is measured is partly general and partly local. The local extension, which occurs near the place of fracture, will affect the whole amount of extension to a degree that depends on the transverse dimensions of the piece as well as on its quality in respect of plasticity. A fine wire of iron or steel 8 inches long will stretch little more in proportion to its length than a very long wire of the same material, for with small transverse dimensions the local part of the stretching will be unimportant. On the other hand, a steel bar with a diameter say of 1 inch will show something like twice as much extension, in proportion to its length, as will be shown by a long rod.

The experiments of M. Barba* show that, in material of uniform quality, the percentage of extension is constant for test-pieces of similar form, that is to say, for pieces of various size in which the transverse dimensions are varied in the same proportion as the length. It is to be regretted that in ordinary testing it is not practicable to reduce the pieces to a standard form, with one proportion of transverse dimensions to length, since an arbitrary

* *Mém. de la Soc. des Ing. Civ.*, 1880; see also a paper by Mr W. Hackney, "On the Adoption of Standard Forms of Test-Pieces," *Min. Proc. Inst. C. E.*, 1884.

choice of length and cross-section gives results which are incapable of direct comparison with one another.

51. Forms of Test-Pieces. The form chosen for test-pieces in tension tests affects not only the extension but also the ultimate strength. In the first place, if there is a sudden or rapid change in the area of cross-section at any part of the length under tension (as at *AB*, fig. 18), the stress will not be uniformly distributed there. The intensity will be greatest at the edges *A* and *B*, and the piece will, in consequence, pass its elastic limit at a less value of the total load than would be required if the change from the larger to the smaller section were gradual. In a non-ductile material, rupture will for the same reason take place at *AB*, with a less total load than would otherwise be borne. On the other hand, with a sufficiently ductile material, although the section *AB* is the first to be permanently deformed, owing to lack of uniformity in the distribution of the stress there, rupture will preferably take place at some section not near *AB*, because at and near *AB* the contraction of sectional area which precedes rupture is partly prevented by the presence of the projecting portions *C* and *D*. Hence, too, with a ductile material samples such as are sketched in fig. 19,

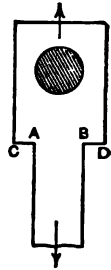

Fig. 18.

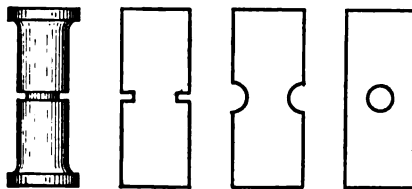

Fig. 19.

in which the part of smallest section between the shoulders or enlarged ends of the piece is short, will break with a greater load than could be borne by long uniform rods of the same section. In good wrought-iron and mild steel the flow of metal preceding rupture and causing local contraction of section extends over a length six or eight times the width of the piece; and, if the length throughout which the section is uniform be materially less than this, the process of flow will be rendered more difficult and the

breaking load of the sample will be raised*. Forms of test-piece are to be preferred in which the length along which the section is uniform is not less than 8 or 10 times the greatest transverse dimension, and if the piece has enlarged ends the change of section should not be quite abrupt.

These considerations as to the choice of forms of test-pieces have a wider application than to the mere interpretation of special tests. An important practical case is that of riveted joints, in which the metal left between the rivet-holes is subjected to tensile stress. It is found to bear, per square inch, a greater pull than would be borne by a strip of the same plate, if the strip were tested in the usual way with uniform section throughout a length great enough to allow complete freedom of local flow †.

51A. Fracture by tearing: Effect of Flaws. A transverse nick or crack producing discontinuity in the material of a piece under stress causes the stress to be very unequally distributed in its neighbourhood. Round the edge of the crack there may be so intense a concentration of stress that the material there tears, and the tear tends to spread as each part in turn becomes subjected to the concentrated stress that occurs at the edge of the discontinuity. The fractured surfaces of a piece broken in this way present a different appearance from that of an ordinary fracture by tension. There is little or no drawing out, even in plastic material, and the crystalline character of the structure, which is masked in an ordinary fracture by the fibrous appearance which the final drawing out produces, makes itself apparent. An abrupt fracture of the kind may be produced by making a nick in the side of a bar and then bending it, or allowing a heavy weight to drop on it while it is supported as a beam. Such a process of fracture may be carried out in a single operation, if the stress is great enough, but a few

* The greater strength of nicked or grooved specimens seems to have been first remarked by Mr Kirkaldy (*Experiments on Wrought Iron and Steel*, p. 74, also *Experiments on Fagersta Steel*, p. 27). See also a paper by Mr E. Richards, on tests of mild steel, *Journ. Iron and Steel Inst.*, 1882.

† See Kennedy's "Reports on Riveted Joints," *Proc. Inst. Mech. Eng.* 1881-5. In the case of mild-steel plates a drilled strip may have as much as 12 per cent. more tensile strength per square inch than an undrilled strip. With punched holes, on the other hand, the remaining metal is much weakened, for the reason referred to in § 44.

repetitions of a considerably smaller stress will suffice to produce it. Thus if a nicked bar is bent back and forth several times, or if a weight is dropped on it repeatedly, the bar being turned round between each fall of the weight and the next, a fracture exhibiting crystalline structure results.

An action more or less similar to this occurs in the case of a flaw, such as may be due in steel to the presence of a flattened air bubble or a film of some foreign substance. In many instances such a flaw is only detected after the piece has been in use for a long time, and it then shows itself by producing an abrupt fracture. Examples of such fracture are found especially in railway axles, screw shafts of steam-ships and other pieces subjected to repeated reversals of stress. Examination of the fractured surfaces generally shows that there has been a gradual "creeping" of the flaw: in other words that the original discontinuity, which may have been exceedingly small, has spread by a very gradual progressive action under the influence of reversals of stress. This "creeping" of the flaw may go on very slowly at first, while the flaw is still small, but as the area of discontinuity becomes greater and the stress on the remaining area consequently increases, creeping goes on faster and the later stages of the break-down are comparatively rapid; finally the piece parts with a sudden snap. The fracture which results from a creeping flaw generally presents the appearance which might be expected in brittle material, no matter how great the plasticity may actually be. A railway axle, for example, of the mildest and most plastic steel has been known to break with a sharp fracture like a rod of glass after running for some months under the usual bending stresses, the fracture resulting from the development of a small flaw which gradually caused a crack to spread across the section. In other instances such cracks have been detected during their growth before they have led to the complete fracture of the piece.

52. Comparative Strength of Long and Short Rods.

The tensile strength of long rods is affected by the length in the following way. With a perfectly homogeneous material, no difference should be found in the strength of rods of equal sectional area and of different lengths, provided the length of both be great enough to prevent the action described in § 51 from affecting the result. But, since no material is perfectly

homogeneous, the longer rod will in general be the weaker, offering as it does more chances of a weak place; and the probable defect of strength in the long rod will depend on the degree of variability of the material. When the degree of variability has been established by numerous tests of short samples, the strength which a rod of any assigned length may be expected to possess can be calculated by an application of the theory of probabilities. A theory of the strength of long bars has been worked out on this basis by Prof. Chaplin*, and has been experimentally confirmed by tests of long and short samples of wire. The theory does not apply when the length is so small that the action of § 51 enters into the case, and the experimental data on which it is based must be taken from tests of samples long enough to exclude that action.

53. Fracture by Tension or by Compression. In tension tests, rupture may occur by direct separation over a surface which is nearly plane and normal to the line of stress. This is usual in hard steel and other comparatively non-ductile materials. Or it may occur by shearing along an oblique surface. In very ductile samples these two modes of rupture are frequently found in combination, and the fractured surface is made up of a central core broken by direct tension while round it is a ring over which separation has taken place by shearing. The shorn ring often forms a continuous cone or crater round a flat core.

In compression tests of a plastic material, such as mild steel, a process of flow may go on without limit; the piece, which must of course be short enough to avoid buckling, shortens and bulges out in the form of a cask. This is illustrated by fig. 20 (from one of Fairbairn's experiments), which shows the compression of a circular cylinder of steel (the original height and diameter of which are shown by the dotted lines) by a load equal to 100 tons per square inch of original sectional area. The surface over which the stress is distributed becomes enlarged and the total load must be increased in a corresponding degree to

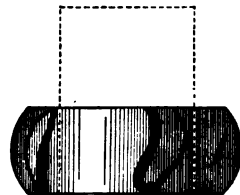

Fig. 20.

* *Van Nostrand's Engineering Magazine*, Dec. 1880; *Proc. Engineers' Club of Philadelphia*, March, 1882.

maintain the process of flow*. The bulging often produces longitudinal cracks, as in the figure, especially when the material is fibrous as well as plastic (as in the case of wrought-iron). A brittle material, such as cast-iron, brick, or stone, yields by shearing on inclined surfaces as in figs. 21, 22, which are taken from Hodgkinson's experiments on cast-iron†. The simplest fracture of this kind is exemplified by fig. 21, where a single surface (approximately a plane) of shear divides the compressed block into two wedges. With cast-iron the slope of the plane is such that this simple mode of fracture can take place only if the height of the block is not less than about one and a half the width of the base. When the height is less the action is more complex. Shearing must then take place over more than one plane, as in fig. 22, so that cones or wedges are formed by which the surrounding portions of the block are split off. The stress required to crush the block is conse-

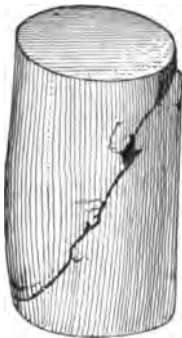

Fig. 21.

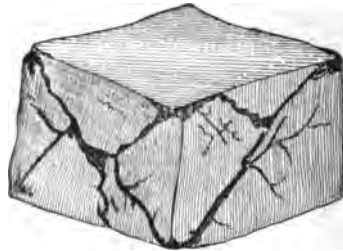

Fig. 22.

quently greater than if the height were sufficient for shearing in a single plane.

54. Inclination of Surfaces of Shear in Tension and Compression Tests. The inclination of the surfaces of shear, when fracture takes place by shearing under a simple stress of pull or push, is a matter of much interest, throwing some light on the question how the resistance which a material exerts to stress of one kind is affected by the presence of stress of another kind,—

* For examples, see Fairbairn's experiments on steel, *Rep. Brit. Ass.*, 1867.

† *Report of the Royal Commissioners on the Application of Iron to Railway Structures*, 1849; see also *Brit. Assoc. Rep.*, 1837.

a question scarcely touched by direct experiment. At the shorn surface there is, in the case of tension tests, a normal pull as well as a shearing stress, and in the case of compression tests a normal push as well as shearing stress. If this normal component were absent the material (assuming it to be isotropic) would shear in the surface of greatest shearing stress, which, as we have seen in § 9, is a surface inclined at 45° to the axis. In fact, however, it does not shear on this surface. Hodgkinson's experiments on the compression of cast-iron give surfaces of shear whose normal is inclined at about 55° to the axis of stress*, and Kirkaldy's, on the tension of steel, show that when rupture takes place by shear the normal to the surface is inclined at about 25° to the axis†. These results show that normal pull diminishes resistance to shearing and normal push increases resistance to shearing. In the case of cast-iron under compression, the material prefers to shear on a section whose normal is inclined at 55° , on which the intensity of shearing stress is only 0.94 of its value on the surface of maximum shearing stress, because on that surface the normal push is only 0.66 of its value on the surface of maximum shearing stress.

The same point is beautifully illustrated by the markings known as Lüder's or Hartmann's lines which frequently appear on the surface of metal strained beyond its limit of elasticity. When a test piece of mild steel, copper, or other soft metal, with a smooth surface, is stretched enough to begin to take permanent set, one or more bands often appear on its surface indicating that the material is yielding locally by shear. The bands are parallel and have, for each metal, a definite inclination to the axis of pull. In general two systems of bands are seen, equally inclined in opposite directions to the axis. As the process of straining goes on these bands become more and more numerous, but their inclination does not change. According to Hartmann‡ the inclination of these bands to the axis ranges, in various metals, from 58° to 65° . These bands are aggregate effects of the slips which are taking place in individual crystals, and must not be confused with the slip-lines referred to in § 49. They serve to show the general directions along which large slips are taking place in the piece as

* *Op. cit.*

† *Op. cit.*

‡ L. Hartmann, *Distribution des déformations dans les métaux soumis à des efforts*. Paris 1896. See also Report of the Congress on Testing Materials of Construction, Paris, 1901.

a whole. They show, moreover, that these slips do not occur on surfaces inclined at 45° to the axis, although it is on such surfaces that the shearing stress is greatest, but that the slips preferably occur on surfaces where the shearing stress is less, but where its effects are assisted by the presence of a greater amount of normal pull. It is the extent to which the normal component relieves what may be called the internal friction of the substance that determines the general inclination of the surface on which shear occurs.

55. Fatigue of Metals. A matter of great practical as well as scientific interest is the weakening which materials undergo by repeated changes in their state of stress. It appears that in some if not in all materials a limited amount of stress-variation may be repeated time after time without appreciable deterioration in the strength of the piece; in the balance-spring of a watch, for instance, tension and compression succeed each other some 150 millions of times in a year, and the spring works for years without apparent injury. In such cases the stresses lie well within the elastic limits. On the other hand, the toughest bar breaks after a small number of bendings to and fro, when these pass the elastic limits, although the stress may have a value greatly short of the normal ultimate strength.

A laborious research by Wöhler*, extending over twelve years, has given much important information regarding the effects on iron and steel of very numerous repeated alternations of stress from positive to negative, or between a higher and a lower value without change of sign. By means of ingeniously contrived machines he submitted test-pieces to direct pull, alternated with complete or partial relaxation from pull, to repeated bending in one direction and also in opposite directions, and to repeated twisting towards one side and towards opposite sides. The results show that a stress greatly less than the ultimate strength (as tested in the usual way by a single application of load continued to rupture) is sufficient to break a piece if it be often enough removed and restored, or even alternated with a less stress of the same kind. In that case, however, the variation of stress being

* *Die Festigkeits-Versuche mit Eisen und Stahl*, Berlin, 1870, or *Zeitschr. für Bauwesen*, 1860-70; see also *Engineering*, vol. xi., 1871. For early experiments by Fairbairn on the same subject, see *Phil. Trans.*, 1861.

less, the number of repetitions required to produce rupture is greater. In general, the number of repetitions required to produce rupture is increased by reducing the range through which the stress is varied, or by lowering the upper limit of that range. If the greatest stress be chosen small enough, it may be reduced, removed, or even reversed many million times without destroying the piece. Wöhler's results are best shown by quoting a few figures selected from his experiments. The stresses are stated in centners per square zoll* ; in the case of bars subjected to bending they refer to the top and bottom sides, which are the most stressed parts of the bar.

I. Iron bar in direct tension :—

Stress.		Number of Applications causing Rupture.	Stress.		Number of Applications causing Rupture.
Max.	Min.		Max.	Min.	
480	0	800	320	0	10,141,645
440	0	106,901			
400	0	340,853	440	200	2,373,424
360	0	480,852	440	240	Not broken with 4 millions.

II. Iron bar bent by transverse load :—

Stress.		Number of Bendings causing Rupture.	Stress.		Number of Bendings causing Rupture.
Max.	Min.		Max.	Min.	
550	0	169,750	400	0	1,320,000
500	0	420,000	350	0	4,035,400
450	0	481,950	300	0	Not broken with 48 millions.

III. Steel bar bent by transverse load :—

Stress.		Number of Bendings causing Rupture.	Stress.		Number of Bendings causing Rupture.
Max.	Min.		Max.	Min.	
900	0	72,450	900	400	225,300
900	200	81,200	900	500	764,900—mean of two trials.
900	300	156,200	900	600	Not broken with 33½ mills.

IV. Iron bar bent by supporting at one end, the other end being loaded ; alternations of stress from pull to push caused by rotating the bar :—

Stress.		Number of Rotations causing Rupture.	Stress.		Number of Rotations causing Rupture.
From + to -			From + to -		
320		56,430	220		3,632,588
300		99,000	200		4,917,992
280		183,145	180		19,186,791
260		479,490	160		Not broken with
240		909,810			132½ millions

* According to Bauschinger (*loc. cit.*, p. 44), the centner per square zoll in which Wöhler gives his results is equivalent to 6·837 kilos per square cm., or 0·0434 ton per square inch.

From these and other experiments Wöhler concluded that the wrought-iron to which the tests refer could probably bear an indefinite number of stress changes between the limits stated (in round numbers) in the following table. The ultimate tensile strength was about 20 tons per square inch :—

Stress in Tons per Sq. Inch.	
From pull to push.....	+7 to -7
From pull to no stress.....	13 to 0
From pull to less pull	19 to 10½

Hence it appears that the actual strength of this material varies in a ratio which may be roughly given as 3 : 2 : 1 in the three cases of (a) steady pull, (b) pull alternating with no stress, very many times repeated, and (c) pull alternating with push, very many times repeated. For steel Wöhler obtained results of a generally similar kind. His experiments were repeated by Spangenberg, who extended the inquiry to brass, gun-metal, and phosphor-bronze*. On the basis of Wöhler's results formulas have been devised by Launhardt, Weyrauch, and others to express the probable actual strength of metals under assigned variations of stress; these are, of course, of a merely empirical character, and the data are not extensive enough to give them much value†. The general conclusions to which Wöhler's experiments lead have been confirmed by the later researches of Sir B. Baker and Prof. Bauschinger‡. They show how important it is to take account of the variability of the load in selecting a factor of safety.

In recent experiments by Mr J. C. W. Humfrey and the author§ the microscope has been applied to watch the process by which iron breaks down or becomes fatigued under repeated reversals of stress. The first visible effect is the production of slip-bands here and there on individual crystals. These appear even when the

* *Ueber das Verhalten der Metalle bei wiederholten Anstrengungen*, Berlin, 1875.

† See Weyrauch, "On the Calculation of Dimensions as depending on the Ultimate Working Strength of Materials," *Min. Proc. Inst. C.E.*, vol. lxiii. p. 275; also a correspondence in *Engineering*, vol. xxix.; and Unwin's *Machine Design*, chap. ii.

‡ For details of the experiments bearing on the subject, see Prof. Unwin's book on *The Testing of Materials of Construction*, chap. xii.

§ The Fracture of Metals under repeated alternations of stress. *Proc. Roy. Soc.* 1902.

greatest stress is somewhat short of the elastic limit (as determined by an ordinary tensile test). As the process goes on these slip-bands become more numerous and also grow broader. Their edges turn rough and burred, apparently as a result of grinding of one surface over the other in the plane in which slip has occurred. At a later stage some of the slip-bands develop into cracks: the cracks finally spread from crystal to crystal and fracture ensues. In specimens of Swedish iron, with a breaking strength of 23.6 tons per square inch and an elastic limit (in tension) of 13 tons per square inch, it was found that a stress of 9 tons per square inch was sufficient to bring about fracture after many reversals, and that stresses of only 7 or 8 tons per square inch developed slip-bands which might have turned into cracks had the process been sufficiently long continued.

As in the case of fracture due to a creeping flaw, the fracture of a fatigued piece takes place abruptly without local deformation, although the material may be highly plastic. When the condition of fatigue has gone so far as to initiate a crack at any place in the material the crack of course tends to spread in the same manner as a crack which has its origin in a flaw.

56. Imperfection of Elasticity. Wöhler's experiments, dealing, as all experiments must deal, with a finite number of stress-changes, leave it an open question whether there are any limits within which a state of stress might be indefinitely often varied without finally destroying the material. It is natural to suppose that a material possessing perfect elasticity would suffer no deterioration from stress-changes lying within limits up to which the elasticity is perfect. But these limits, if they exist at all, are probably very narrow. Indeed, in the case of iron, there is indirect evidence that all alteration of stress whatsoever affects the molecular structure in a way not consistent with the notion of perfect elasticity. When the state of stress in iron is varied, however slowly and however little, the magnetic and thermo-electric qualities of the metal are found to change in an essentially irreversible manner*. Every variation leaves its mark on the quality of the piece; the actual quality at any time is a function of all the states of stress in which the piece has previously been placed. It can scarcely be doubted that sufficiently refined

* See papers by the author, *Phil. Trans.*, 1885, 1886.

methods of experiment would detect a similar want of reversibility in the mechanical effects of stress, even when alterations of stress take place very slowly. When they take place fast there is a want of reversibility due to another cause, pointed out by Lord Kelvin, namely, that the application of stress produces change of temperature, and consequently causes exchanges of heat to occur between the piece and its surroundings. Such exchanges of heat are necessarily irreversible, and hence the rapid application and removal of a load must do work on the piece even although a very slow application and removal of the load does no work. In other words, a material may be perfectly elastic in respect to indefinitely slow loading, and yet show dissipation of energy when the load is applied and removed somewhat quickly. Apart from this, however, there is probably in all materials some *static* hysteresis in the process of loading and unloading, corresponding to imperfection of elasticity under indefinitely slow applications of load*. And in stress-changes which occur rapidly, experiments show in general more dissipation of energy, for strains within the usually accepted elastic limits, than can be accounted for by reference to the variations of temperature caused by straining. This is shown by the rate at which the vibrations of elastic solids subside. In experiments made by Lord Kelvin on the subsidence of the torsional oscillations of bodies suspended from wires, the bodies oscillating so as to twist the wire alternately to one and the other side, it was found that the rate of subsidence increased, in other words, the internal molecular friction causing imperfect elasticity increased from day to day, when the wire was kept oscillating, but when the wire was allowed to rest for a day its elasticity improved. Thus it appears that repeated changes of stress have a cumulative effect in reducing elasticity, while Wöhler's experiments show that they have also a cumulative effect in reducing strength. It may be conjectured that repeated strains induce a change in molecular structure of which the fatigue in strength and the fatigue in elasticity are two manifestations. A period of rest in a "fatigued" piece tends to restore elasticity: probably it would also tend to restore strength, but on this point experiments are as yet wanting.

Annealing in any case serves to cure fatigue, and restores the

* See experiments by the author, *Rep. Brit. Assoc.* 1889, p. 502.

primitive quality of the piece in respect of both strength and elasticity.

It is remarkable that a piece which has been fatigued by many variations of stress, as in Wöhler's experiments, and has had its endurance nearly exhausted, does not in general show any marked defect either in strength or in plasticity on being tested to rupture in the ordinary way.

57. Cumulative Effect of Blows and Shocks. An effect which is sometimes confused with the phenomenon investigated by Wöhler, but which should be treated as distinct from that, is the failure which is sometimes brought about through the cumulative effect of shocks. When a blow or shock expends kinetic energy in straining a piece the strain, which may be more or less general or more or less local according to the circumstances of the case, is such that the work done in producing it is equal to the energy of the blow. It may often happen that this exceeds the amount of work capable of being taken up in an elastic strain, and the limit of elasticity may, therefore, be passed in the strain to which some portion of the piece is subjected. This causes some local hardening, and as a similar effect may be frequently repeated the capacity of the piece to endure shocks may gradually become exhausted. A familiar instance is afforded by the chain of a winch, which in the course of protracted use may be exposed to many shocks from the slipping of the weight it lifts or from other causes. Any such shock may be said to use up a portion of the plasticity of the material, and the cumulative effect is to produce a hardening which might in time cause an unexpected failure if the chain were not periodically restored by annealing it.

Fracture under successive blows, as in the testing of rails by placing them as beams resting on two supports, and allowing a weight to fall on the middle from a given height, results from the accumulated effect which is brought about in consequence of the energy of each blow being greater than can be absorbed by merely elastic strain.

58. Initial Internal Stress. When stress is set up by applying an external load the behaviour of the piece may depend to a material degree on the existence of initial internal stress. A state of stress may exist while there is no external load. Taking

some one section across the piece, we may for example have tensile stress occurring over some parts of the section, balanced so far as the resultant is concerned by compressive stress over other parts of the section. A piece which is entirely free from such actions is sometimes spoken of (in a phrase due to Prof. Karl Pearson) as being in a *state of ease*. Internal stress, existing without the application of force from without the piece, must satisfy the condition that its resultant vanishes over any complete cross-section. It may exist in consequence of set caused by previously applied forces (a case of which instances are given below), or in consequence of previous temperature changes, as in cast-iron, which is thrown into a state of internal stress by unequally rapid cooling of the mass when it is being cast. Thus in a spherical or cylindrical casting an outside shell solidifies first, and has become partially contracted through cooling by the time the inside has become solid. The inside then contracts, and its contraction is resisted by the shell, which is thereby compressed in a tangential direction, while the metal in the interior is pulled in the direction of the radius. Allusion has already been made to the fact, pointed out by J. Thomson, that the defect of elasticity under small loads which Hodgkinson discovered in cast-iron is probably due to initial internal stress. In plastic metal a nearly complete state of ease is brought about by annealing; even annealed pieces, however, sometimes show, in the first loading, small defects of elasticity which may be due at least in part to initial stress, as they disappear or become reduced when the load is reapplied.

59. Influence of Temperature on Strength. Little is exactly known with regard to the effect of temperature on the strength of materials. Some metals, notably iron or steel containing much phosphorus, show a marked increase in brittleness at low temperatures, or "cold shortness." Experiments on the tensile strength of wrought-iron and steel show in general little variation within the usual atmospheric range of heat and cold. The tensile strength appears to be slightly reduced at low temperatures, but to be practically unaffected through heating up to say 100° Cent. When the temperature exceeds about 250° C. the tensile strength falls off rapidly, and at 550° C. it is only a third or a fourth the normal value*. Reference may be made,

* See *Report of a Committee of the Franklin Institute, 1837; Fairbairn, Brit.*

in this connection, to the effect which a "blue heat," or temperature considerably short of red heat, is believed to have on the plasticity and strength of iron, and more especially of mild steel. It appears that steel plates and bars bent or otherwise worked at a blue heat not only run a much more serious risk of fracture in the process than when worked either cold or red-hot, but become deteriorated in such a way that brittleness may show itself later when the metal is cold*.

Mild steel may be rendered more or less brittle by "overheating" it. Overheating may occur through comparatively brief exposure to such a temperature as 1400° C. or by protracted exposure to somewhat lower temperatures. Thus steel has been found to lose much of its plasticity by being kept for twelve hours or so at a temperature of 1200° C., and in some specimens of soft iron brittleness has even been induced by very prolonged exposure to 700° or 800° C. On the other hand a brief heating to 900° or 1000° C. followed by fairly rapid cooling in air is advantageous in giving plasticity, and may be used with good effect to remove the influence of previous overheating†.

Prolonged exposure of wrought-iron or steel even to so moderate a temperature as 40° C. or 60° C. is known to bring about a gradual change of molecular structure, which shows itself in a marked variation of the magnetic quality of the metal, the primitive state, however, being reverted to when the metal is reannealed. It is not yet known whether any corresponding mechanical changes are brought about in this way in annealed metal, although, as we have seen in § 42, a brief exposure to such a temperature has an immense effect on a piece that has been newly overstrained.

Assoc. Rep., 1856; Styffe on *Iron and Steel*, trans. by C. P. Sandberg. Notices of these and other experiments will be found in Unwin's *Testing of Materials*, in Thurston's *Materials of Engineering*, ii. chap. x., in *Jour. Franklin Inst.* 1881, vol. cxii. p. 241, and in papers by J. J. Webster, *Min. Proc. Inst. C.E.*, vol. lx., and A. Martens, *Zeitschr. des Ver. Deutsch. Ing.*, 1883.

* Stromeyer, "The injurious Effect of a Blue Heat on Steel and Iron," *Min. Proc. Inst. C.E.*, vol. lxxxiv., 1886.

† On the subject of overheating see papers by Mr J. E. Stead and Prof. Heyn in the *Journal of the Iron and Steel Institute* for 1898 and 1902.

CHAPTER IV.

THE TESTING OF MATERIALS.

60. Testing Machines. In most modern testing machines the load is applied by means of hydraulic pressure acting on a piston or plunger to which one end of the specimen is secured, and the stress is measured by having the other end of the specimen connected to a lever or system of levers provided with adjustable weights. The hydraulic piston takes up the stretch as the test proceeds, doing work upon the test-piece, and the lever is kept floating by adjusting the weight on it as the stress increases. In many small machines and in some large ones screw-gearing is used instead of hydraulic power to apply force to the specimen.

Springs are used in a few small machines (such as wire-testers) instead of weights, as a means of measuring the load. Another plan, which has been successfully employed even in large machines, is to make one end of the specimen act on a diaphragm forming part of a hydrostatic pressure gauge.

61. Single-Lever Machine with vertically placed Test-Piece. A favourite and convenient form of testing machine, now used in many English laboratories and steel-works, is illustrated in fig. 23. This machine, designed by Mr J. H. Wicksteed, uses a single lever with a single heavy travelling weight as the means of measuring the force.

The illustration shows a 50-ton machine, but machines of similar design have been built to exert a force of 100 tons or more. The illustration includes an auxiliary apparatus for drawing autographic diagrams of load and strain, which will be referred to later. The testing machine proper consists of a strong upright to which the cylinder of the hydraulic ram is attached near the foot, and a

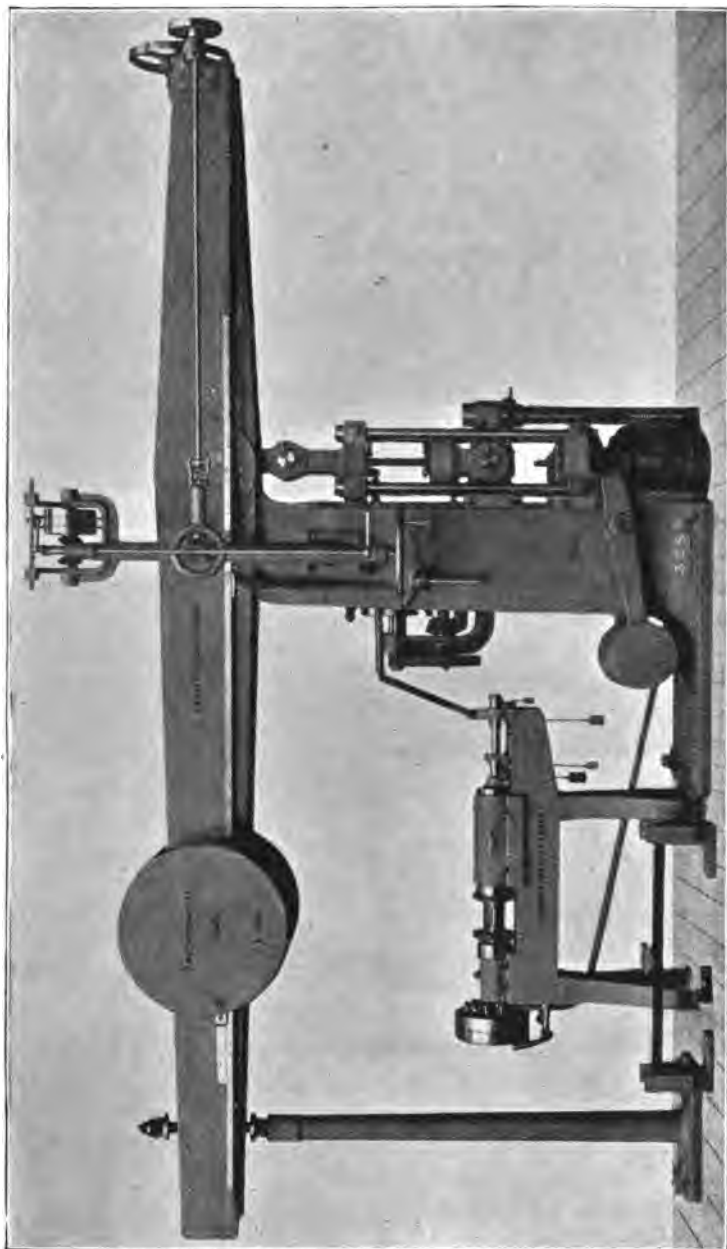

Fig. 23. Wicksteed's Single Lever 50-ton Testing Machine.

long lever or weigh-beam resting by a knife-edge on the top of the upright, and carrying a travelling weight. The traveller weighs 1 ton; it carries a vernier by which its position is read against a divided scale on the beam. The specimen is vertically placed: its lower end is secured in a cross-head which is pulled down by the hydraulic ram below. The upper end is secured in a shackle which hangs from an inverted knife-edge on the beam. The beam itself oscillates about another knife-edge, at a short distance from the first, resting on the top of the supporting upright or "cat-head." The travelling weight is moved by means of a screw concealed within the beam, which takes its motion through spur wheels from a parallel shaft provided with a Hooke's joint in the axis of oscillation of the beam. This shaft is turned either by a handle wheel or by taking motion from a power-driven counter-shaft above—an arrangement which is chiefly convenient for running the weight back quickly after each test has been made. A counterpoise which is seen projecting behind the pillar near the ground serves to force up the ram when the hydraulic pressure is relieved. The pressure in the hydraulic cylinder is applied in some instances by means of a screw-pump, but a more convenient plan is to use an accumulator, or better still a "hydraulic intensifier" by which the work is done by admitting water from an ordinary low pressure main under a large piston. This large piston forces home a small hydraulic plunger, thereby producing a greatly increased intensity of pressure in the fluid on which the plunger acts, and that in its turn is transmitted to the straining ram of the machine. Such an apparatus has the advantage of allowing the load to be applied smoothly without shock, and at a slow or comparatively quick rate at will. The rate of application is regulated by a throttle valve through which water from the low-pressure main has to pass on its way to the large cylinder of the intensifier.

The machine is designed for tests in compression and bending as well as tension. Four columns, which are removable when tension tests only are to be made, connect the upper shackle with a platform in the shape of a cross-beam which hangs below the cross-head which is pulled down by the hydraulic ram. The arrangement is that of two stirrups linked with one another, one of them inverted, so that when the two pull against each other a block of material placed between them becomes compressed. For tests in bending

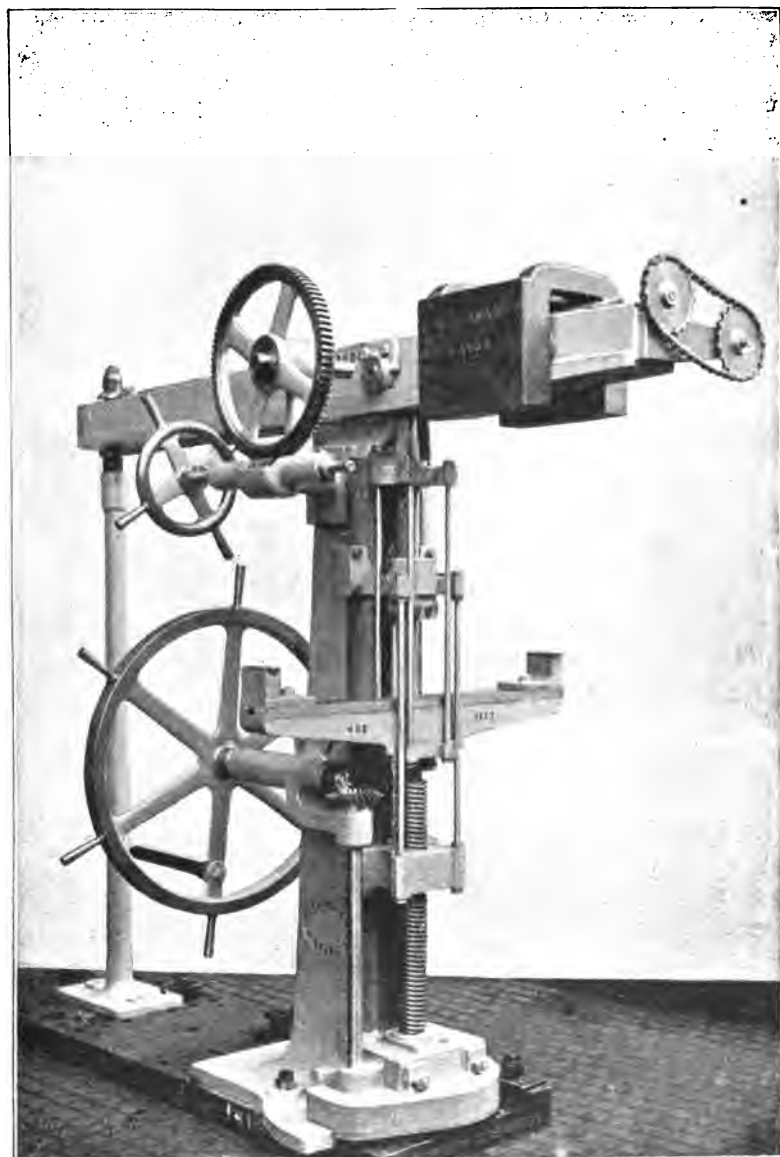

Fig. 24. Five-ton Testing Machine.

one of the stirrups—namely the beam which hangs by columns from the upper shackle—is made some four or five feet long and carries supports at its ends for the ends of the piece that is to be bent, while the cross-head presses down on the middle of the piece. In both cases the force which is exerted is measured by means of the weigh-beam and travelling weight, just as in tension tests. The arrangement for compression and bending tests will be clear from fig. 24, which shows a small machine by Mr Wicksteed capable of exerting a force of 5 tons, in which the force is exerted by means of a screw driven by hand. This machine has a supplementary arrangement for torsion tests. A worm and worm-wheel at the top of the upright serve to twist a specimen, one end of which is secured in the axle of the worm-wheel, while the other end is secured in a socket which projects from the side of the weigh-beam. The axis of the specimen under torsion is in the same line with the knife-edge about which the beam is free to oscillate. Each of the “knife-edges” in the weigh-beam of these machines is the edge of a square-cut bar of steel. The knife-edges are long enough to prevent the load on them from exceeding 5 tons to the linear inch. With edges formed and proportioned in this way the friction is insignificant. Care has to be taken in testing to make the load come on smoothly, and as far as possible to keep the beam from being thrown into oscillation, otherwise its inertia causes the maximum stress on the specimen to exceed the amount shown by the travelling weight.

62. Calibration of Vertical Machines. Machines in which the specimen hangs vertically have the advantage of allowing the accuracy of their calibration to be readily tested by suspending a heavy weight of known amount from the upper shackle. The two points to be tested are (1) the distance between the knife-edges, and (2) the value of the travelling weight. The value of the travelling weight can be tested by the following method without removing it from the beam. Move the traveller until the beam stands horizontally midway between the stops. Then hang to a point of the beam at a known distance l from the fulcrum, and near the end, a known weight w . To balance the beam we must now move back the traveller through a distance l_1 which is measured by means of the scale and vernier. Then T the weight of the traveller is given by the equation

$$Tl_1 = wl.$$

In Mr Wicksteed's machines the weight of the traveller is generally 1 ton. It is conveniently checked by hanging a 56 lb. weight to the beam at a point distant by 40 of the principal scale divisions from the fulcrum. The traveller should then require to be moved back one scale division to reestablish equilibrium.

The distance between the knife-edges (x) is next determined by hanging a known heavy weight (say 1 ton) from the shackle and observing how far in scale divisions the traveller has to be moved to make the beam stand horizontal. Calling the weight W that is hung on, and l_2 the distance the traveller has to be moved, we have

$$Wx = Tl_2,$$

an equation which determines x in scale divisions. Or, alternatively, when the weight W has been hung on, we may restore the equilibrium not by moving the traveller but by applying a measured (small) weight at some distant point on the beam, in the manner described above for testing the weight of the traveller.

63. Other Testing Machines using Weights and Levers.

For ordinary testing, in which the specimens to be dealt with are of no great length, nothing could exceed the convenience, accuracy and simplicity of the vertical machine. A preference however is in some cases felt for horizontal machines on account of the greater readiness with which they can be arranged to deal with exceptionally long test-pieces. The Werder testing machine, which is much used in Continental laboratories, is a horizontal machine with a single lever, so arranged that both the application and measurement of the load are effected at one end of the specimen, the other end being merely held fixed in the frame of

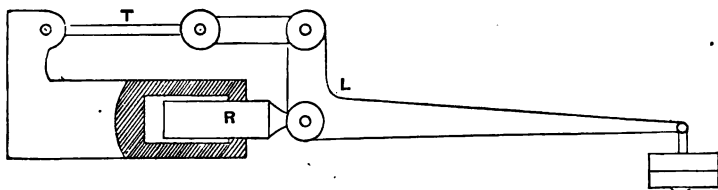

Fig. 25. Scheme of Werder Testing Machine.

the machine. The lever is of the bell-crank type with a short vertical arm and a long horizontal one and a fulcrum at the knee. The lever is pushed out bodily in a horizontal direction by the

hydraulic ram: its short arm pulls one end of the specimen, and weights to measure the pull are applied to the long arm. The arrangement is shown diagrammatically in fig. 25. *T* is the piece under test, and *L* is the bell-crank lever to the long arm of which weight is applied while the ram *R* keeps this arm horizontal as the specimen stretches.

Fig. 26 illustrates the general arrangement of a recent horizontal machine designed by Mr Wicksteed. Here tension tests are made in the space marked *Q*, and compression tests in either of the

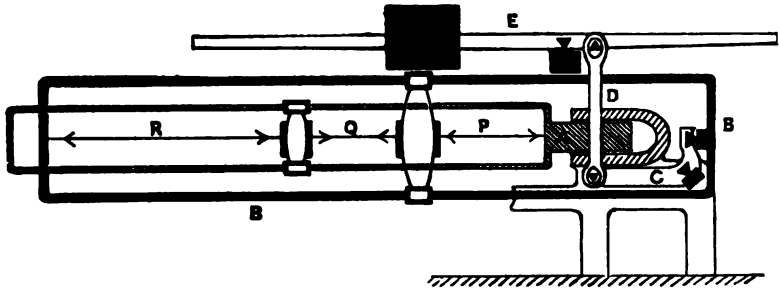

Fig. 26. Scheme of Wicksteed's Horizontal Testing Machine.

spaces *P* or *R**. The thrust of the hydraulic ram *A* is communicated through the test-piece to the suspended frame *B*, and thence through the bell-crank lever *C* and link *D* to the weigh-beam *E*. A view of the complete machine, taken from a photograph, is given in fig. 27. The cross-beam at the left-hand end is for bending tests.

In many other testing machines a system of two, three, or more levers is employed to reduce the force between the specimen and the measuring weight. Probably the earliest machine of this class was that of Major Wade†, in which one end of the specimen was held in a fixed support, and the stretch was taken up by screwing up the fulcrum plate of one of the levers. In most multiple-lever machines, however, the fulcrums are fixed, and the stress is applied to one end of the specimen by hydraulic power or by screw gearing, which of course takes up the stretch, as in the single-lever machines already described. Kirkaldy, who was one of the earliest as well as one of the most assiduous workers

* An account of this machine will be found in *Engineering*, July, 1898.

† *Report of Experiments on Metals for Cannon*, Philadelphia, 1856.

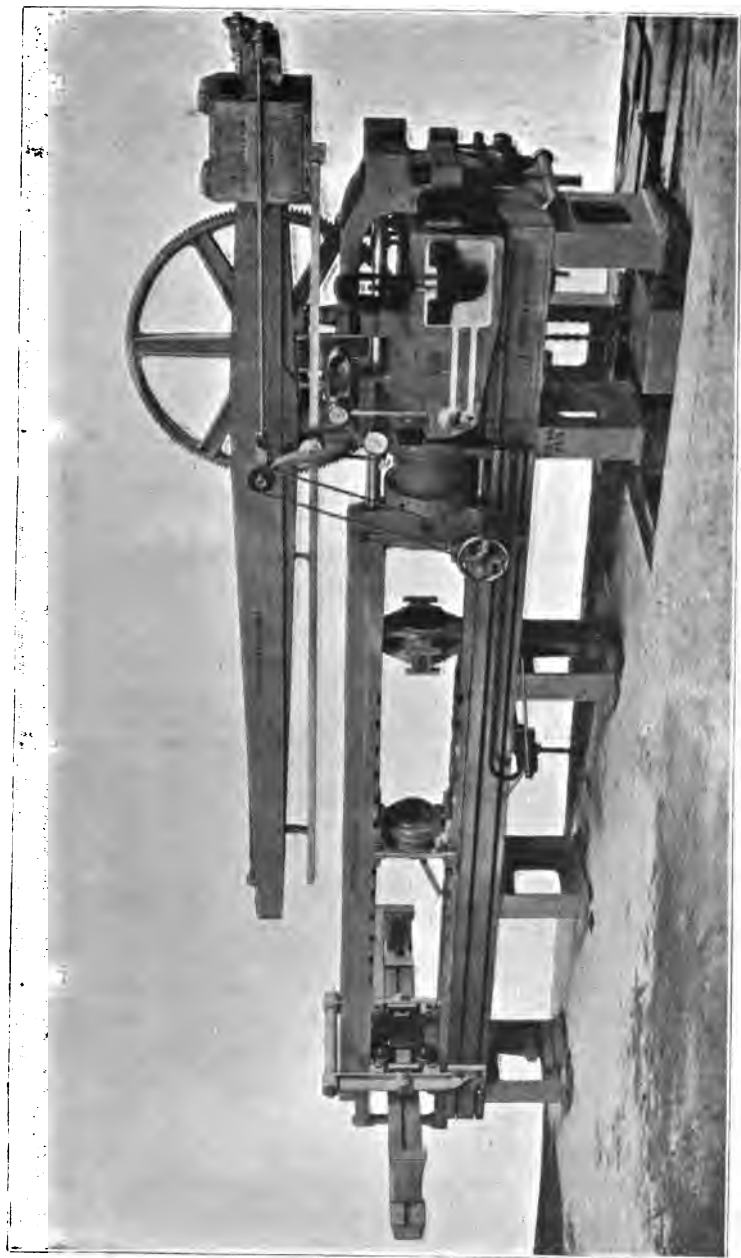

Fig. 27. Wicksteed's Horizontal Testing Machine.

in this field, applied in his 1,000,000 lb. machine a horizontal hydraulic press directly to one end of the horizontal test-piece. The other end of the piece was connected to the short vertical arm of a bell-crank lever; the long arm of this lever was horizontal, and was connected to a second lever to which weights were applied. In some of Messrs Fairbanks's machines the multiple-lever system is carried so far that the point of application of the weight moves 24,000 times as far as the point of attachment to the test-piece. The same makers have employed a plan of adjusting automatically the position of the measuring weight, by making the scale lever complete an electric circuit when it rises or falls so that it starts an electric motor which runs the weight out or in. Generally the measuring weight is adjusted by hand. In some, chiefly small, machines, the weight adjusts itself by means of another device. It is fixed at one point of a lever which is arranged as a pendulum, so that, when the test-piece is pulled by force applied at the other end, the pendulum lever is deflected from its originally vertical position and the weight acts with increasing leverage.

Multiple-lever machines have the advantage that the measuring weight is reduced to a conveniently small value, and that it can be easily varied to suit test-pieces of different strengths. On the other hand, their multiplicity of joints makes the leverage somewhat uncertain and increases friction.

64. Other Testing Machines. Diaphragm Machines.

Hydraulic testing machines have been employed in which one end of the specimen is held in a fixed support and the stress is inferred from the pressure of the fluid in the hydraulic ram by which the load is applied, this pressure being read on a gauge. Machines of this class are open to the obvious objection that the friction of the hydraulic plunger causes a large and very uncertain difference between the force exerted by the fluid on the plunger and the force exerted by the plunger on the specimen. It appears, however, that in the ordinary conditions of packing the friction is very nearly proportional to the fluid pressure, and its effect may therefore be allowed for with some exactness. The method is not to be recommended for work requiring precision, unless the plunger be kept in constant rotation on its own axis during the test, in which case the effects of friction are almost entirely eliminated.

In another important class of testing machines which we may distinguish as diaphragm machines, the stress (applied as before to one end of the piece, by gearing or by hydraulic pressure) is measured by connecting the other end to a free diaphragm, on which a liquid acts whose pressure is determined by a gauge. Fig. 28 shows a simple machine of this class (used in 1873 for testing wire by Sir W. Thomson and the late Prof. Fleeming Jenkin). The wire is stretched by means of a screw at the top,

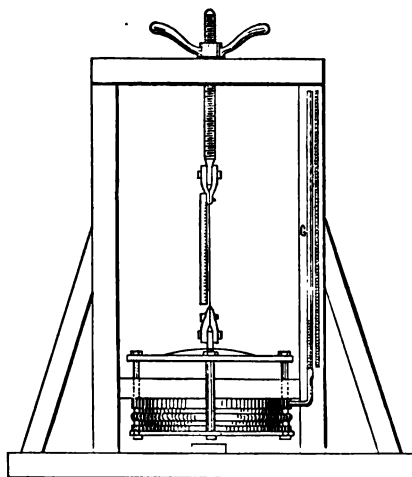

Fig. 28. Hydraulic Machine for Testing Wire.

and pulls up the lower side of a hydrostatic bellows; water from the bellows rises in the gauge-tube *G*, and its height measures the stress.

In a larger testing machine of this type by Thomasset, the specimen pulls horizontally on the short end of a bell-crank lever, the long end of which presses on a horizontal diaphragm, consisting of a metallic plate and a flexible ring of india-rubber. The pressure on the diaphragm displaces mercury from a chamber, which the diaphragm covers, and causes a column of mercury to rise in a gauge-tube, thereby indicating the amount of the stress. The same principle is made use of in a number of other testing machines. It has found its most important application in the remarkable testing machine of Watertown arsenal, built in 1879 by the U.S. Government to the designs of Mr A. H. Emery. This

is a horizontal machine, taking specimens of any length up to 30 feet, and exerting a pull of 360 tons or a push of 480 tons by a hydraulic press at one end. The stress is taken at the other end by a group of four large vertical diaphragm presses, which communicate by small tubes with four similar small diaphragm presses in the scale case. The pressure of these acts on a system of levers which terminates in the scale beam. The joints and bearings of all the levers are made frictionless by using flexible steel connecting plates instead of knife-edges. The total multiplication at the end of the scale beam is 420,000*.

65. Testing Machines for special purposes. Small testing machines are made for such special purposes as determining the tensile strength of cement in briquettes, or the transverse strength of cast-iron bars, or for applying torsion. A usual test of cast-iron is to lay a rectangular bar with a section 2 inches deep and 1 inch wide on supports 3 feet apart, and load it in the middle until it breaks. The load required is usually between 1 and 2 tons, and it is generally applied by means of a lever with

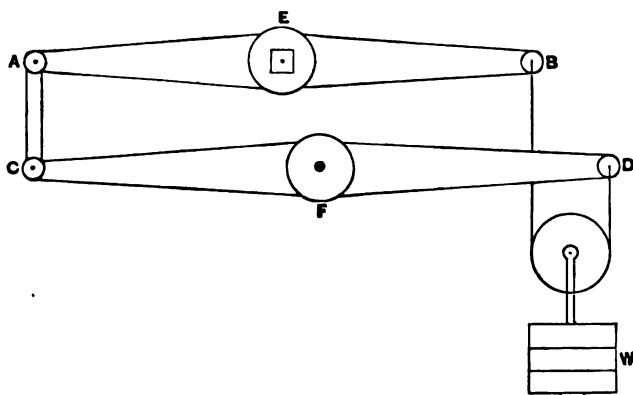

Fig. 29. Arrangement of Levers in Torsion Testing Machine.

a travelling weight. In torsion tests a worm and worm-wheel at one end of the specimen serve to apply twist, and the moment of

* For details of the Emery Machine see *Report of the U.S. Chief of Ordnance 1883, Appendix 24*; also Unwin's *Testing of Materials* and *Proc. Inst. Mech. Eng. 1888*.

the couple may be measured at the other end either by a single loaded lever, or better by using a system of levers such as that sketched in fig. 29. The object in this arrangement is to secure that a pure couple will be applied. The lever AB , to which the specimen is secured at E , has equal arms. Half of the weight W acts directly at B . The other half acts at D on one arm of the auxiliary lever CD , which is pivoted by a knife-edge on a fixed support at its middle point F . This produces an upward thrust in the link CA equal to half the weight W , and hence the twisting moment on the specimen is constituted by a pair of equal and opposite forces forming a pure couple and escaping the shearing force which a weight simply applied at the end of a single lever would produce.

66. Attachment of the specimens in tensile tests. The problem of holding a test-piece fairly so as to ensure that the pull will be symmetrically distributed about the axis, and that fracture will not occur at or near the grips through local inequality in the stress, presents some difficulty, especially when the material is of a rigid (non-plastic) kind. The shackles in which the piece is held are hinged, to let them adjust themselves to the line of pull. The test-piece is often made with enlarged ends on which screws are cut, and the end is screwed into a nut the seat of which is shaped to form part of a sphere, thus providing a ball-and-socket joint at each end of the bar. Or the enlarged end terminates in a shoulder inside of which two half rings are slipped on to form a collar, and the half rings have spherical curvature where they bear on the shackle. With plastic materials such as wrought-iron and mild steel there is no difficulty in getting a fair test of ultimate strength, even with the simplest appliances for holding the specimen, for the plastic yielding which precedes rupture wipes out any inequality there may be in the distribution of the stress to begin with. The trouble of screwing the ends or of forming shoulders on the test-piece may therefore be dispensed with, and a simpler attachment by wedge grips may be used. In this, which is the commonest of all methods of holding bars or strips of plate in commercial testing, each end of the bar stands between two wedges of hard steel the faces of which, where they press on the bar, are rough while the backs are smooth and are greased to make them slip down easily in a tapered recess in the shackle. When pull comes

on the bar, the wedges are drawn down with it and press themselves against the specimen with so much force that the rough faces of the wedges bite into the plastic surface of the bar and hold it securely. In testing flat plate-strips the ends of the test-piece are usually cut a little wider than the main body of the piece, thereby giving an enlarged surface for the wedge to act on. With round or square bars no enlargement of the ends need be used, but the wedges instead of being plane have a groove with roughened sides, so that each end of the bar is gripped at four places round its circumference. Fig. 30 shows in sectional elevation and plan the shackles of a Wicksteed 100-ton machine with flat wedges holding a strip of plate as test-piece. The tapered hole in which the wedges sit is not cut out of a single piece of metal, but out of two half-rings which are separately free to turn round the shackle, thus admitting of adaptation to cases where the opposite sides of the strip are not quite parallel.

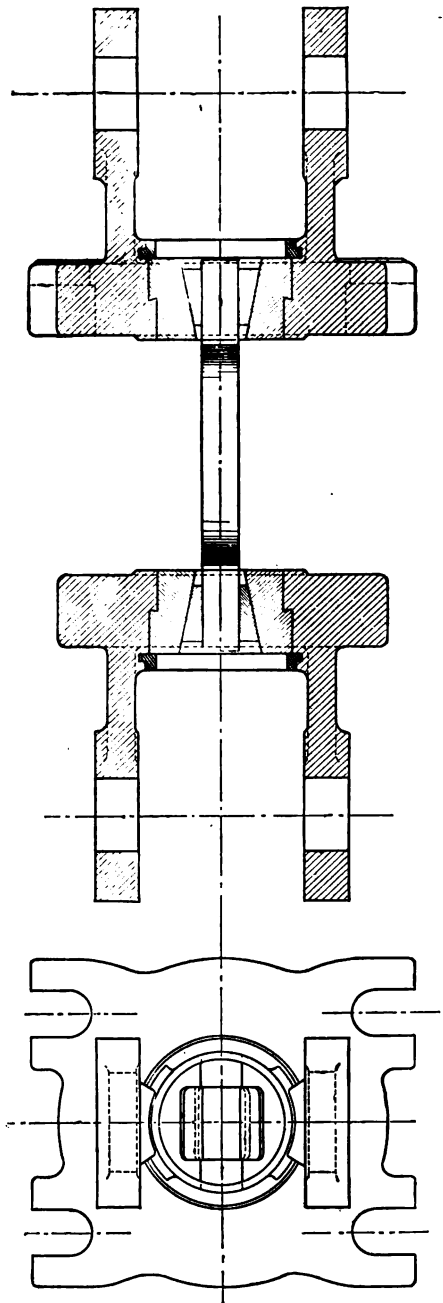

Fig. 30. Shackles in Wicksteed's Vertical Testing Machine.

67. Apparatus for drawing autographic diagrams of extension and load. In laboratory testing the relation of extension (beyond the elastic limit) to load throughout the test may readily be observed by simply applying a pair of beam compasses to two marked points on the specimen (usually 8 inches apart) from time to time as the test proceeds, and transferring the distance to a scale. When testing is to be done rapidly, and a knowledge of this relation is still wanted, some form of autographic recording apparatus is convenient.

In most of the arrangements which have been designed for this purpose, the diagram is drawn by the relative movement of a pencil and a sheet of paper on a drum, one component of the motion being proportional to the extension and the other to the travel of the weight by which the load is measured. In a single lever testing machine, for example such as that shown in fig. 23, a convenient form of recorder is made by supporting the paper drum horizontally on the main standard, setting the pencil carriage on a screwed spindle, which revolves along with the vertical shaft which gives motion to the travelling weight. This makes the pencil advance, parallel to the axis of the drum, through distances proportional to the load. The extension is taken by having two clips firmly secured to the test-piece at points 8 inches apart, with a fine wire or inextensible cord attached to one passing over a pulley on the other, thence over a second pulley on the first, and thence to the paper drum. This causes the drum to be turned round through distances proportional to the extension. In another arrangement, designed by Prof. Unwin*, the wire from the specimen causes a pencil to travel longitudinally, parallel to the axis of the drum, and the drum revolves through distances proportional to the displacement of the travelling weight.

In Mr Wicksteed's hydraulic recorder, which appears on a separate frame behind the main standard in fig. 23, the drum is pulled round by a wire from the specimen, through distances proportional to the extension, and the pencil takes its motion, not from the travelling weight but from the piston of an auxiliary hydraulic cylinder in free communication with the straining cylinder of the machine. This piston compresses a

* *The Testing of Materials of Construction*, chap. vii.

spring in its advance, and therefore its displacement measures the force with which it is pressed out. Its friction is eliminated by keeping it in continuous rotation, and this makes it indicate correctly the pressure in the main straining cylinder. But the net load on the bar bears a somewhat uncertain relation to that pressure, in consequence of the friction of the ram. Mr Wicksteed contends that the friction of the ram is proportional to the pressure, and that a uniform scale is therefore found, the value of which is interpreted by occasional reference to the weigh-beam.

68. Measurement of Young's Modulus by Extensometers. The small strains which occur in a tensile test of non-plastic material, and those which occur during the early stages of the test in material of any kind, require some form of delicate measuring appliance. The name extensometer is given to apparatus designed for this purpose. We have seen that the whole amount of elastic stretching in such a material as wrought-iron amounts to only about $\frac{1}{1000}$ of the length under observation. In measuring the elastic modulus and in determining the true elastic limit we must be able to compare the fractional parts of this strain which are produced by successive increments of load. On an 8-inch length of iron or steel the elastic extension is, in round numbers, about $\frac{1}{1000}$ inch for each ton per square inch of load. Hence to obtain accurate measurements of the modulus there is much advantage in being able to read to, say, $\frac{1}{10000}$ of an inch.

Measurements taken between marks on one side of the bar are so much affected by any bending of the bar through accidental inequality in the distribution of the stress that no credit is to be given them. It is essential either to measure the extensions on opposite sides of the bar and take a mean of the two, or to measure the displacement between two pieces which are attached to the bar in such a way as to share equally in the strain on both sides.

In the experiments of Bauschinger, which take high rank among observations of this class, independent measurements of the strains on two sides of the bar were taken by using mirror micrometers of the type illustrated in fig. 31. There are two clips *a* and *b* clasp-
ing the test-piece at the places between which the extension is to be measured. The clip *b* carries two small rollers, d_1, d_2 , which are free to rotate on centres fixed in the clip. These rollers press on two plane strips attached to the other clip. When the specimen

stretches the rollers are consequently caused to turn through distances proportional to the strain. The amounts by which the

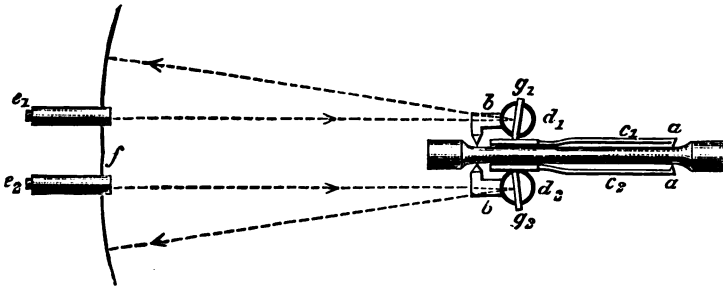

Fig. 31. Scheme of Bauschinger's Extensometer.

rollers turn are read by means of small mirrors, g_1 , g_2 , fastened to the rollers, which reflect the marking of a fixed scale, f , into the reading telescopes e_1 , e_2 . The extension of the bar is deduced from the mean of the two readings. The adjustment of this apparatus is a matter of considerable nicety, and in point of convenience a self-contained form of extensometer is much to be preferred.

Professor Unwin's extensometer (fig. 32) uses two clips, c_1 , c_2 , the upper one of which is free to revolve about the pair of points which attach it to the bar, while the lower one is deprived of this freedom by a set screw s abutting on the side of the bar. Each of the clips has a level tube l fastened to it, and the lower one carries a rod r furnished with a micrometer screw m , the point of which presses against the under side of the upper clip. The screw s is adjusted to make the lower level tube horizontal: then the upper tube is set level also by adjusting m , and

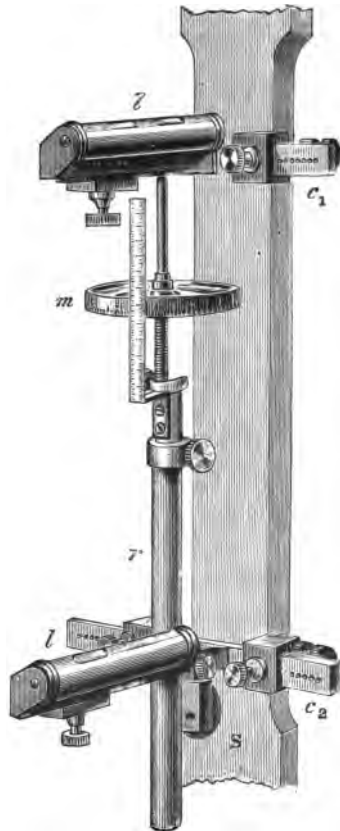

Fig. 32. Unwin's Extensometer.

as the specimen stretches the amount is noted by which m has to be turned to keep the tube level. The instrument reads to $\frac{1}{10000}$ inch.

The author has devised an extensometer of the self-contained class which has proved convenient and accurate in use. It can be quickly applied to any test-piece and no part of it has to be touched while the test is being made. The principle involved is illustrated diagrammatically in fig. 33. There are two clips B and

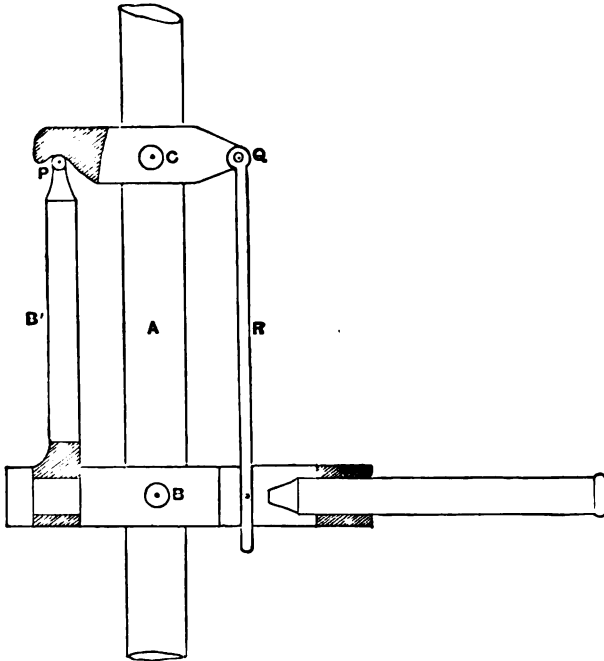

Fig. 33. Scheme of the Author's Extensometer.

C each attached to the test-piece A by the points of two set-screws. The clip B has a projection B' ending in a rounded point P which engages with a conical hole in C : when the bar extends this rounded point serves as a fulcrum for the clip C and hence a point Q , equally distant on the other side, moves relatively to B through a distance equal to twice the extension. This distance is measured by means of a microscope attached to B either on a projection which allows it to point directly towards a mark at Q , or (as in the sketch) the microscope forms a prolongation of B and the motion of Q is brought into the field of view by means

of a hanging rod R . The rod R is free to slide on a guide in B , and carries a mark on which the microscope is sighted. The displacement is read by means of a micrometer scale in the eye-piece of the microscope. The pieces B and B' are jointed to one another in such a way that the bar may twist a little, as it is sometimes liable to do during a test, without affecting the engagement of P with C . This also obviates any need of absolute parallelism in the axes of attachment of the two clips. But the joint between B and B' forms a rigid connection so far as angular movement in the plane of the paper is concerned. This feature is essential to the action of the instrument; it is only then that P serves as a fixed fulcrum in the tilting of A by extension on the part of the specimen.

Fig. 34 is a view of one form of the complete instrument, taken

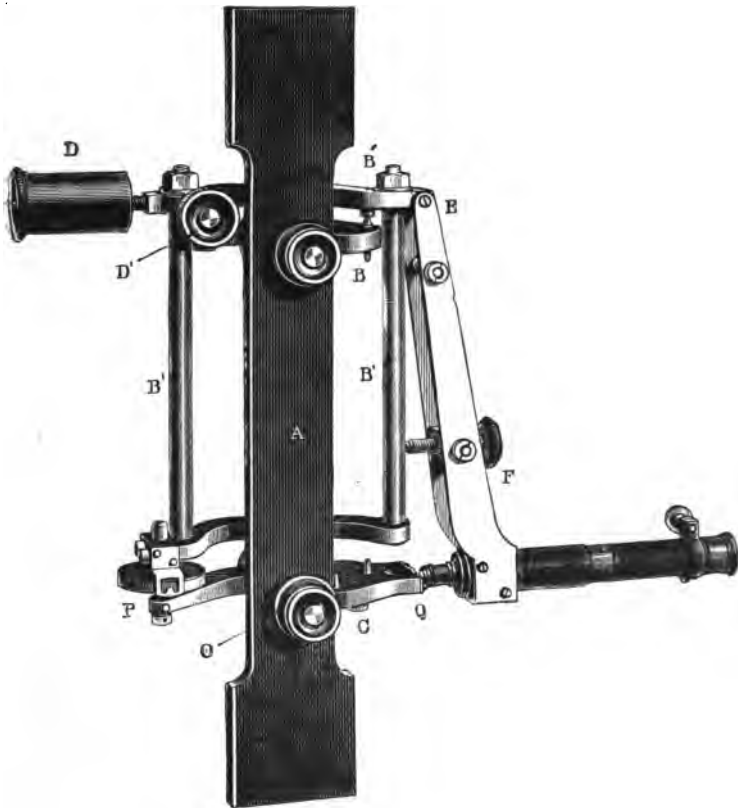

Fig. 34. The Author's Extensometer.

from a photograph*. The clips *B* and *C* are set at 8 inches apart. Here the instrument is inverted, as compared with the scheme of fig. 33. The joint between *B* and *B'* consists, in this instance, of two upright pins fixed in *B*, one of which presses up into a hole and the other into a slot in *B'*, the line of this hole and slot being perpendicular to the axis of the set-screws by which the clip is attached to the rod under test. Hence, so far as movement about the axis of the set-screws is concerned, *B* and *B'* act as a rigid whole. This movement is prevented by the gearing of *P* in the hole in the lower clip *C*. The piece *B'* is here a frame consisting of two parallel steel rods united by a cross-bar at top and bottom, and carrying, besides the screw *P*, the microscope, which is hinged to *B'* about the point *E* vertically above *Q*, and is provided with a focussing screw at *F*. The counterpoise *D*, which is also attached to the piece *B'*, serves to balance the weight of the microscope and make the pressure vertical between *P* and the hole into which it gears. There is a supplementary counterpoise *D'* for adjusting the balance about the axis of the joint between *B* and *B'*. These counterpoises are adjusted so that when the heavy end (*Q*) of *C* is raised, making *P* cease to be in gear with *C*, *P* has no tendency to move in any direction. The excess of weight on the right-hand side of *C* may be made sufficient to produce the requisite pressure at the point *P*, but it is convenient to supplement this pressure by means of a light spring pulling the two together. The frame *BB'* with the microscope may be lifted off, leaving only the two clips attached to the rod.

The object sighted is one side of a wire stretched horizontally across a hole in a plate at *Q*, and illuminated by a small mirror behind. The distances *OP* and *OQ* are in this instance equal, with the effect that the movement of *Q* is double the extension of the rod. The length of the microscope is adjusted, with reference to the scale in the eye-piece, so that the numbers read on the scale correspond to $\frac{1}{80000}$ of an inch of extension. This adjustment is tested by turning the screw *P*, which has a pitch of $\frac{1}{80}$ inch, through one revolution, and observing that the displacement of *Q* is 500 units of the eye-piece scale. In the instrument illustrated in fig. 34 the whole scale comprises 1,400 units, and calibration tests show that throughout the middle 1,200 of them.

* *Proc. Roy. Society*, Vol. 58, May, 1895. •

the proportionality of the scale readings with the real movements of Q is practically perfect.

The scale engraved in the eye-piece of the microscope has 140 divisions, each corresponding to $\frac{1}{8000}$ inch of extension, and by estimation to tenths of a division readings are taken to $\frac{1}{80000}$ inch.

The screw P further serves to bring the sighted mark to a convenient point on the micrometer scale, and also to bring the mark back if the strain is so large as to carry it out of the field of view: thus a single turn of the screw adds 500 scale divisions to

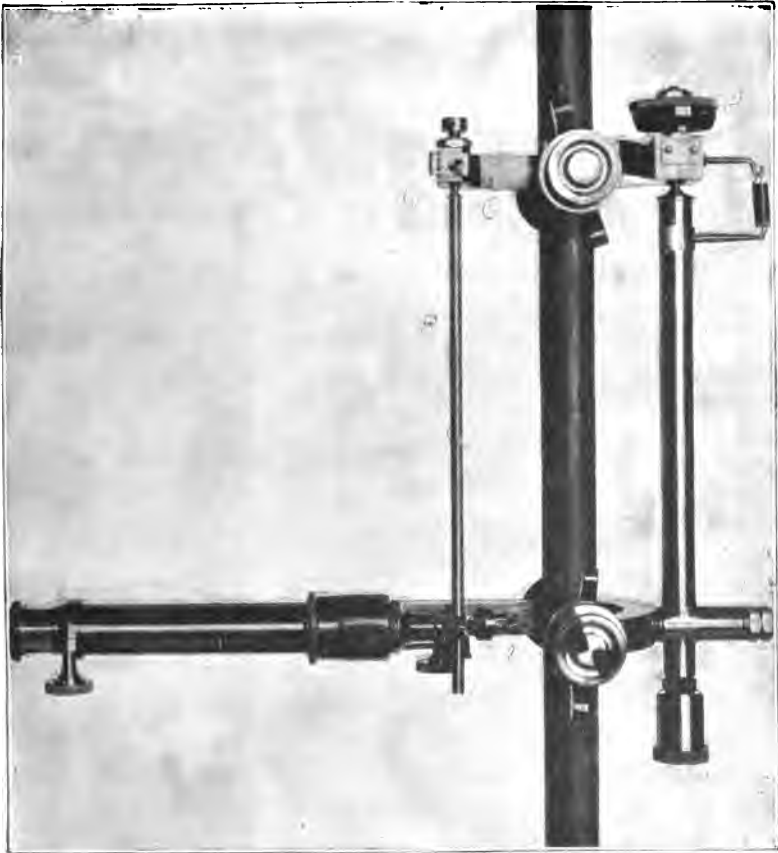

Fig. 35. The Author's Extensometer (Newer Form).

the range shown on the micrometer scale. In dealing with elastic strains there is no need for this, as the range of the scale is itself

sufficient to include them, but it is useful when observations are being made on the behaviour of metals as the elastic limit is passed.

To facilitate the application of the extensometer to any rod a clamp (not shown in the figure) is added by which the clips *B* and *C* are held at the right distance apart with the axes of their set-screws parallel, while they are being secured to the test-piece. Such a clamp is especially convenient when the strain has been carried beyond the elastic limit and it is desired immediately to reset the clips to the standard distance apart after the length between them has materially changed by the extension of the specimen.

The form shown in fig. 34 is applicable to vertical specimens only. A newer and in some respects more simple form, suitable for horizontal or inclined bars as well as for vertical ones, is shown in fig. 35. In this arrangement the microscope forms a prolongation of the clip *B*, and the displacement of the point *Q* in the clip *C* is brought into the field of view by a rod *R*, as in the scheme sketched in fig. 33. A ball-and-socket joint is used between *R* and *C*, and the two are held together by a light spring. The calibrating screw *P* is now fixed in *C* and a hole at the end of it forms the socket for *B'*.

Fig. 36 shows what is substantially the same form of extensometer adapted to measure the elastic compression of short blocks

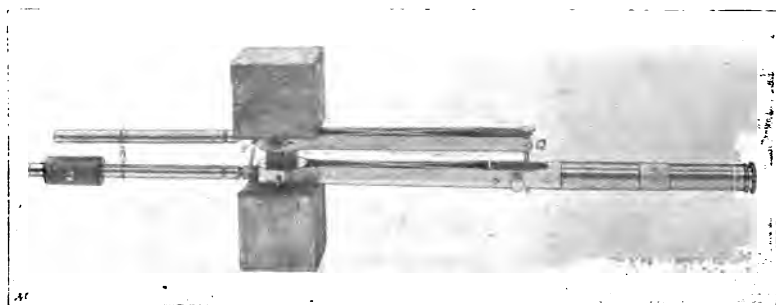

Fig. 36. The Author's Extensometer applied to measure the Elastic Compression of Short Blocks.

Here the length to be dealt with between the clips is only $1\frac{1}{2}$ inches, and the strain of the specimen is mechanically multiplied 10 times

instead of only twice, as in the former case. This is done by extending the clips to the right so that the distance of Q from the axis is 9 times that of P . The prolongations to the left are added to counterpoise the weight, so that the force with which the point P presses against its socket may be vertical. The motion of Q is transferred to the field of the microscope by means of a vertical hanging piece which is jointed to the lever PQ at Q , and carries the mark on which sights are taken. In this instrument the calibrating screw is dispensed with, and the object sighted by the microscope is a small piece of glass on which two fine horizontal lines are engraved at a distance of $\frac{1}{80}$ inch apart. The length of the microscope is adjusted to make these lines include 500 units of the eye-piece scale. Each unit consequently corresponds to a displacement of the glass plate through $\frac{1}{25000}$ inch, or in other words to an extension in the test-piece of $\frac{1}{25000}$ inch.

Extensometers such as have been described are an important adjunct to the testing machine, and are most commonly used along with it. It is however worth while to observe that for many experiments on elasticity the testing machine is not essential.

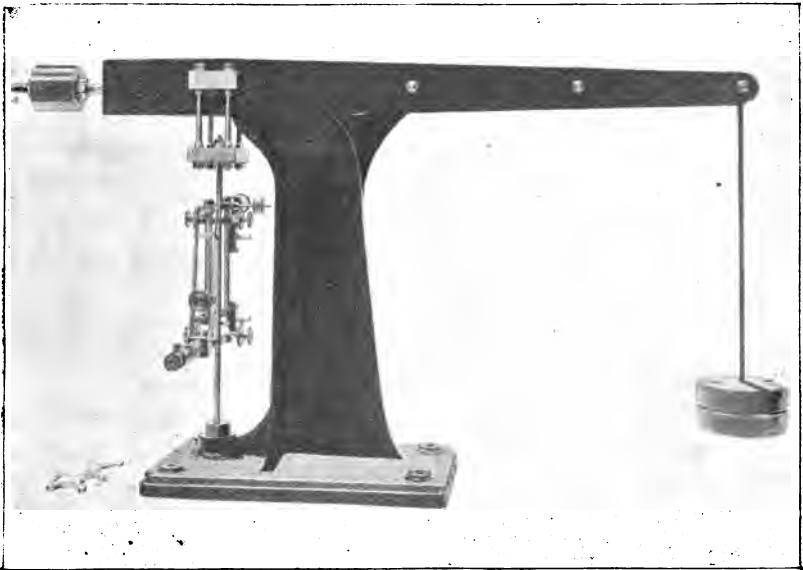

Fig. 37. Small Testing Machine for Elastic Extension of Rods, with Extensometer attached.

So long as elastic strains are dealt with there is no need of hydraulic or other gearing to take up the stretch, and a simple lever may suffice to apply the load. A laboratory apparatus for measuring Young's modulus in rods of various metals is shown in fig. 37. By hanging weights from the end of the lever loads up to 1 ton are applied to the rod, which may conveniently have a diameter of $\frac{1}{4}$ or $\frac{3}{8}$ inch, and an extensometer attached to the rod measures the strain.

69. Measurement of Young's Modulus in Wire. When long pieces of wire are available the elastic extension admits of direct measurement by means of a scale and vernier. A good plan is to hang up two long wires side by side, fastening both to the same support and attaching the scale to one and the vernier to the other. One is kept taut by a load which is not varied during the test. The other is first loaded with a weight sufficient to straighten it, and additional weights are then applied to produce the elastic extension, which is measured by noting the movement of the vernier over the scale. With iron or steel wires, say 20 feet long, the extension will be nearly $\frac{1}{16}$ inch for each ton per square inch of load, and as the load may generally be raised to 10 tons per square inch, and often to much more without passing the elastic limit, the movement of the vernier is sufficient to give fairly accurate determinations of the modulus. The advantage of using a second wire to carry the scale is that any yielding of the support, or any change of temperature such as might occur during the test, affects both wires equally.

When comparatively short pieces of wire are used some means of magnifying the relative displacement is necessary. A convenient plan is to clamp two little blocks to the two wires to serve as platforms on which is placed a small tripod carrying a mirror, two feet of the tripod being supported in a hole and a slot respectively on one of the blocks while the other leg rests on a plane horizontal surface on the other block. When one wire stretches the mirror tilts, and the amount of its tilting is measured by means of a fixed reading telescope and scale. Fig. 38 shows an apparatus for carrying out such measurements. The wires hang inside a tubular stem from a clamp at the top, and a cross-bar attached to the bottom end of one of them carries a constant quantity of load while variable load is applied to the other. The

reading telescope with its attached scale is supported by part of the framework, so that the whole apparatus is self-contained. A fixed shelf may be used in place of the second wire.

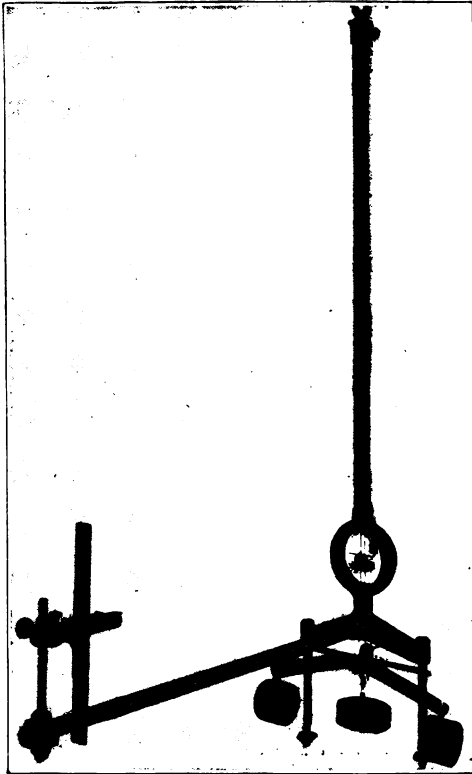

Fig. 38. Apparatus for measuring Elastic Extension of Wires.

In calculating the extension from the scale readings it must be noted that the angle through which the reflected ray turns is twice the angle through which the mirror tilts. Let a be the effective width of the tripod carrying the mirror, namely, the distance from its back foot to the line joining its two front feet, let s be the number of scale divisions by which the reading in the telescope changes when a load is applied, and let b be the distance between the mirror and the scale expressed in scale divisions.

Then the small angle turned through by the ray is $\frac{s}{b}$. The angle

through which the mirror tilts is $\frac{\delta l}{a}$, where δl is the extension of the wire. Hence $\delta l = \frac{as}{2b}$ and is found in the same units as are used in measuring a .

70. Measurement of Young's Modulus by Bending.

Observations of the deflection of a loaded bar supported as a beam on fixed supports, or clamped at one end and free at the other, furnish a convenient method of determining Young's modulus for the material of the bar. When the piece is long and sufficiently flexible to bend considerably, the deflection is readily measured by having a fixed scale behind the beam, with a fixed piece of mirror glass alongside of the scale, so that readings may be directly taken by bringing the eye to the level of the beam until the top edge of the beam covers its reflexion in the mirror behind, and then sighting the position of the edge upon the scale. In dealing with less flexible bars an apparatus like that shown in fig. 39 is useful.



Fig. 39. Apparatus for measuring elasticity by deflection of beams.

There the supporting knife-edges are clamped on a stiff frame like a lathe-bed, and can be set to any desired distance apart.

The deflection is measured by sighting a finely divided glass scale, clamped to the beam, through a reading microscope of low power. A useful addition to the apparatus consists of a little mirror which can be set astride the beam at any place for the purpose of observing the angle of slope there, the tilting of this mirror when the beam is loaded being observed from a distance by means of a reading telescope and scale. This mirror appears in the figure above one of the two supports. In place of loading in the centre, two loads, equal in amount, may be applied at the two extremities of the beam, which are arranged for that purpose to project by equal distances beyond the two supports. The advantage of this method of loading is that the middle portion of the beam between the supports is then subject to uniform bending and to no other kind of strain—a point which will be explained in the chapter dealing with beams.

Let a be half the distance between the supports, and b the distance by which the beam projects beyond each support. It will be shown later (Chapter VII.) that if a load W be applied at the centre the deflection caused there by that load is

$$u_1 = \frac{Wa^3}{6EI},$$

where I is the moment of inertia of the section about a horizontal central axis.

Hence in that case

$$E = \frac{Wa^3}{6u_1I}.$$

Again, if a load W be applied at each extremity, the upward deflection at the centre is given by the equation

$$u_2 = \frac{W\alpha^2b}{2EI},$$

and in that case

$$E = \frac{W\alpha^2b}{2u_2I}.$$

Fig. 40 shows a similar arrangement for observing the deflection of a cantilever or beam held fixed at one end and free at the other. Taking L to denote the whole length from the clamp to

the free end, and assuming the load W to be applied at the free end as in the illustration, the deflection there is

$$u_3 = \frac{WL^3}{3EI}.$$

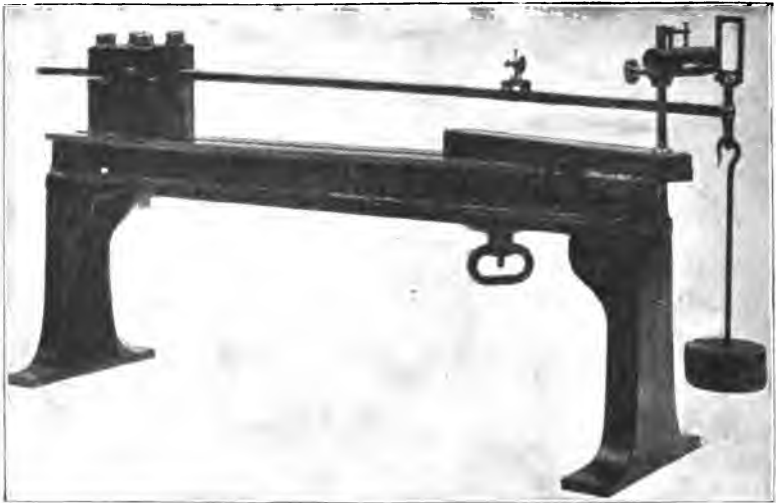

Fig. 40. Apparatus for observing deflection of Cantilever.

The practical difficulty of ensuring that the clamp shall hold the fixed end so securely as to keep it strictly horizontal makes this experiment a less trustworthy means of finding E than the other.

In both cases the apparatus is arranged so that the deflection may be observed at the various points along the length of the bar for the purpose of examining experimentally the curve which a beam of uniform section assumes under a given load or system of loads. The slope may also be determined from point to point along the length by means of the jockey mirror.

71. Measurement of the Modulus of Rigidity. Static Method. This modulus is usually measured by experiments on the torsion of a round rod or wire. It will be shown later that when such a rod is twisted every part of it is in a state of shear, and that within the elastic limit the angle of twist θ (expressed in circular measure) on any length l is connected with the diameter

d , the modulus of rigidity C , and the twisting moment M by the equation

$$\theta = \frac{32lM}{\pi d^4 C},$$

or

$$C = \frac{32lM}{\pi d^4 \theta}.$$

In applying this to measure C in rods of moderate diameter a convenient plan is to find θ by using two long pointers, clamped to the rod near its ends, with their distant ends moving over fixed scales. The difference of the two scale readings measures the twist on the length l between the pointers. When the diameter of the rod is so great as to make the angle of twist too small to be measured in this way, a pair of mirrors clamped on the rod and facing sideways should be used along with a reading telescope and scale for each. An optical pointer has the advantage over a mechanical pointer of doubling the angle, and further it can readily be made of much greater length.

Fig. 41 shows a self-contained apparatus for experiments on the torsion of wires. The wire hangs in the axis of a tubular stem and carries a cylindrical weight round which two cords pass which are led away over pulleys and carry hangers on which equal weights are placed. The wire is consequently twisted by a pure couple, and the angle of twist is read by observing the displacement on a fixed circular scale of a pointer attached to the cylindrical weight.



Fig. 41. Apparatus for measuring Modulus of Rigidity by the torsion of wires.

72. Measurement of the Modulus of Rigidity. Kinetic Method by Torsional Oscillations. Let a circular rod or wire be held fixed at one end and have attached rigidly to the other end a mass which is set into oscillation by applying a twist and letting go. Then for elastic twists the moment acting at any instant on the mass to restore it to its normal position will be proportional to the angle of twist at that instant, and the oscillations will consequently be of the simple harmonic type, and will be executed in the same period whether they are large or small, provided they lie within the elastic limit. Thus if t is the period of time taken to make each complete oscillation, and μ is the twisting moment per unit of angle (in other words, the constant ratio of the twisting moment M to the angle θ), we have

$$t = 2\pi \sqrt{\frac{I}{\mu g}},$$

where I is the moment of inertia of the oscillating mass about the axis of the rod. The factor g converts the moment μ into kinetic units.

But by the principle stated in § 71 (and to be proved later)

$$\frac{M}{\theta} \text{ or } \mu = \frac{\pi d^4 C}{32l}.$$

Hence
$$t^2 = \frac{4\pi^2 I}{\mu g} = \frac{128\pi l I}{gd^4 C},$$

and
$$C = \frac{128\pi l I}{gd^4 t^2},$$

which allows C to be found by observing the period t , when the diameter and length of the rod and the moment of inertia of the oscillating mass are known.

The apparatus shown in fig. 41 allows this means of measuring C to be carried out on the same wire to which the static test is applied. The cords have simply to be disconnected and the heavy cylindrical mass to be set oscillating. Its moment of inertia is $\frac{mr^2}{2}$, r being its radius and m its mass.

Another convenient form of oscillator consists of a hollow

cylinder or ring with a rectangular bar across the top to allow the wire to be attached, fig. 42. Its moment of inertia is

$$\frac{m_1(r_1^2 + r_2^2)}{2} + \frac{m_2(a^2 + b^2)}{3},$$

where m_1 is the mass of the ring, r_1 and r_2 its external and internal radii; m_2 is the mass of the bar, a its half length and b its half breadth measured horizontally.

The method of oscillations may be used with rods of considerable diameter by attaching a cross bar to which heavy masses may be applied. The moment of inertia is most readily found by noting the period when the amount of the applied masses is changed. Thus after observing the period t_1 , let an additional mass, m , be applied at each end of the cross bar, and let t_2 be the value then found for the increased period of oscillation. Calling the original moment of inertia I , the moment of inertia in the second state is $I + 2ma^2$, where a is the distance from the axis to the points at which the weights are applied, and

$$\frac{t_1^2}{t_2^2} = \frac{I}{I + 2ma^2},$$

from which

$$I = \frac{2ma^2 t_1^2}{t_2^2 - t_1^2}.$$

73. Maxwell's Needle used as Torsional Oscillator.

This is a particularly convenient oscillator for use in measuring the modulus of rigidity of wires. It consists (fig. 43) of a tube

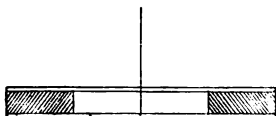

Fig. 43.



Fig. 43a.

Maxwell's Needle.

into which four equal short pieces of tube can be slipped, each of the short pieces being one-fourth of the length of the long tube.

Two of the short pieces are empty and two are filled with lead. By placing the tubes as shown in figs. 43 and 43a the moment of inertia of the system can have two values given to it, I_1 and I_2 , of which I_1 (corresponding to fig. 43) is considerably the greater.

To express the change in moment of inertia, or $I_1 - I_2$, let a be the half length of the long tube, m_1 the mass of each of the two short tubes that are filled with lead, and m_2 the mass of each of the empty short tubes.

Then the system is changed by shifting two masses each equal to $m_1 - m_2$, so that the distance of the centre of gravity of each from the axis changes from $\frac{3}{4}a$ to $\frac{1}{4}a$.

Hence

$$I_1 - I_2 = 2(m_1 - m_2)\left(\frac{9}{16}a^2 - \frac{1}{16}a^2\right) = (m_1 - m_2)a^2.$$

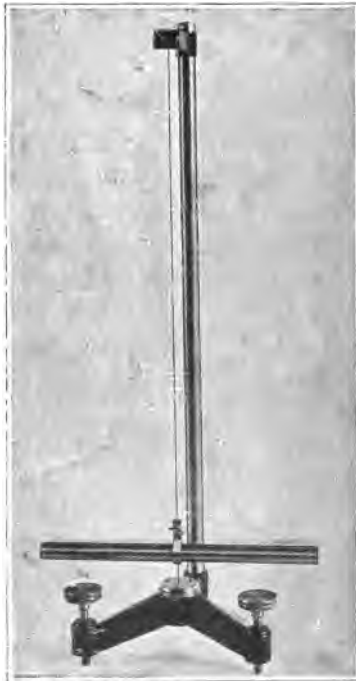

Fig. 44. Apparatus for experiments on torsional oscillation, using Maxwell's Needle.

Let t_1 and t_2 be the observed periods of oscillation in the two cases respectively.

Then

$$\frac{t_1^2}{t_2^2} = \frac{I_1}{I_2},$$

$$\frac{t_1^2}{t_1^2 - t_2^2} = \frac{I_1}{I_1 - I_2} = \frac{I_1}{(m_1 - m_2) a^2},$$

or

$$\frac{I_1}{t_1^2} = \frac{(m_1 - m_2) a^2}{t_1^2 - t_2^2}.$$

But

$$C = \frac{128\pi l}{gd^4} \cdot \frac{I_1}{t_1^2},$$

and hence we obtain without calculating I the following equation for C ,

$$C = \frac{128\pi l}{gd^4} \cdot \frac{(m_1 - m_2) a^2}{t_1^2 - t_2^2}.$$

A self-contained apparatus for experiments on the torsion of wires by means of Maxwell's needle is shown in fig. 44.

74. Results of Tests. Data for Cast-iron. Cast-iron, the product of the blast furnace, has properties which vary widely in different specimens, depending as they do in great measure on the quantity of carbon which the iron contains, as well as on the manner in which the carbon is united to the iron. The amount of carbon may range from 2 up to nearly 5 per cent. In white cast-iron it exists mainly in a state of combination with the iron: in grey cast-iron it consists mainly of graphite mixed with the iron. Silicon is also present in amounts that vary from less than 1 up to 3 per cent. or even more, along with small quantities of sulphur, phosphorus and manganese. Comparatively great softness is obtained when the amount of carbon present in the combined state is small, although the whole amount of carbon may be considerable, but a much stronger iron is obtained by having 1 per cent. or more of carbon in the combined state.

The tensile strength of cast-iron may be as low as 4 tons per square inch, and may be as high as 20 tons. These are exceptional figures, and values ranging between 8 and 12 tons per square inch are more usual in good foundry iron. The compressive strength may be as low as 20 tons per square inch, and as high as nearly 100 tons in exceptional cases: its ordinary values range

from 40 to 60 tons per square inch. The shearing strength appears from such experiments as have been published to be somewhat lower than the tensile strength. The great compressive strength of cast-iron leads to its being largely used in the construction of columns, but the facility with which it can be melted and cast into any desired shape is the property to which its application in engineering is mainly due. Very grey cast-iron is the kind which becomes most perfectly fluid when melted, and consequently takes most exactly the form of the mould, but a less grey mixture is to be preferred when strength is a chief desideratum.

It is only within very narrow limits that cast-iron can be said to show even approximate proportionality between stress and strain. Hodgkinson's experiments on long cast-iron bars showed that both in extension and in compression the strain was about '00017 for each ton per square inch of load, in the initial stages of the loading. This makes, in round numbers,

$$E = \frac{1}{.00017} = 6000 \text{ tons per sq. inch.}$$

In experiments on short cast-iron bars Prof. Unwin* observed strains ranging in various specimens from '000133 to '000156 per ton per square inch. The corresponding limits of E are in round numbers 7,500 and 6,400 tons per square inch. Values of the modulus of rigidity C in cast-iron generally lie between 3,400 and 3,000 tons per square inch.

75. Wrought-iron. In wrought-iron, which is manufactured from cast-iron by the processes of puddling and rolling, only a small fraction of the carbon present in the cast-iron survives the action of the puddling furnace. The carbon remaining in the iron is reduced to less, often to much less, than one-quarter of one per cent. Traces of manganese, sulphur, silicon and phosphorus are also found. The metal as rolled has a markedly fibrous structure, arising chiefly from intermixture with particles of slag which the process of rolling draws out into long filaments.

Good wrought-iron bars have a tensile strength of about 25 tons per square inch, and will stretch as much as 20 per cent. on an 8-inch length before breaking, the section becoming reduced

* *The Testing of Materials of Construction*, 1st ed. p. 265.

at the place where fracture occurs to 50 or 60 per cent. of its original size. In good wrought-iron plates the strength of strips cut along the direction of rolling ranges generally from 20 to 24 tons per square inch, and that of strips cut across the direction of rolling from 18 to 22. In plates of poor quality the tensile strength may be as low as 16 tons per square inch. Bars having a tensile strength of say 23 or 25 tons have usually a well-marked yield-point in the neighbourhood of 15 or 17 tons. The crushing strength of wrought-iron is rather indefinite: it is often taken as $\frac{3}{4}$ of the tensile strength. The shearing strength ranges from about 16 to 20 tons per square inch, but is according to Bauschinger's experiments notably less when a plate is sheared in a plane parallel to its faces. In that direction the shearing strength may be only 8 or 10 tons. The value of E for wrought-iron lies in most cases between 12,000 and 13,000 tons per square inch: it appears that 12,500 may be taken as a fair mean value. The modulus of rigidity C is about 5,000.

76. Steel. The name steel is applied to a great variety of materials which differ mainly in the proportion of carbon they contain. At one end of the range is very mild steel, made in the Siemens furnace or in the Bessemer converter, which contains less than 0.2 per cent. of carbon, and differs from wrought-iron chiefly in the greater homogeneity which it possesses as a consequence of being rolled from a cast ingot instead of from a puddled ball interspersed with slag. At the other end of the range are high carbon steels, containing 0.5 per cent. or more of carbon, capable of being hardened and tempered by the treatment mentioned in § 46, and in some cases made by an entirely different process, namely, by adding carbon to wrought-iron in the cementation furnace, with or without subsequent melting of the steel in a crucible. Mild steel containing from 0.15 to 0.25 per cent. of carbon has now to a very great extent superseded wrought-iron in engineering construction. Its tensile strength is about one-third greater, and its capacity for plastic yielding before fracture is also greater.

Specimens of mild steel bars or plates containing about 0.2 per cent. of carbon show in general a tensile strength of 28 to 30 tons per square inch, and stretch about 25 per cent. on the 8-inch length. As the percentage of carbon is increased the

plasticity diminishes, but the tensile strength becomes greater, at least until the percentage of carbon is as high as 0.5 per cent. To a considerable extent the strength and plasticity depend on the amount of work which has been done upon the ingot in rolling it down into the form of bar or plate, and the highest strength is found in wire, which is the finished product on which the largest amount of work has been spent. Steel wire containing a fairly high percentage of carbon may show a tensile strength of 80, 100, or even 120 tons per square inch. No rule can be laid down as to the relation of the strength to the percentage of carbon, for except in the mildest steel, the strength may be much affected by the state of temper, and in all cases it is also affected by the presence of other constituents and by the amount of rolling or drawing down which the ingot has undergone, as well as by the question whether the piece has been subsequently annealed. The following results obtained by Bauschinger are quoted from a table in Prof. Unwin's book, and will serve to give a general idea of the way in which the strength of steel may depend on the percentage of carbon it contains. The steels to which these tests relate were made by the Bessemer process.

Percentage of carbon	Tensile strength tons per sq. inch	Extension in 16 inches per cent.	Shearing strength tons per sq. inch	Elastic limit in tension tons per sq. inch
·14	28.1	22	21.7	18
·19	30.4	20	23.6	21
·46	33.8	18	22.8	22
·51	35.6	14	25.5	22
·54	35.3	18	25.0	22
·55	35.9	18	25.4	21
·57	35.6	18	23.1	21
·66	40.0	14	27.2	24
·78	41.1	11	26.3	24
·80	45.9	9	30.6	25
·87	46.7	8	31.7	27
·96	52.7	7	37.0	31

The contraction of area at fracture falls progressively from 49 per cent. in the mildest of these steels to 10 per cent. in the steel which is most rich in carbon.

It is remarkable that no great difference is found in the

modulus of elasticity whether the steel has much or little carbon. In the examples just quoted the modulus E was found to vary irregularly between 13,700 and 14,900 tons per square inch, but the values have no correspondence with the percentage of carbon.

In the light of more recent experiments these values of the modulus of elasticity appear to be rather high. Tests made by a committee of the British Association (*B. A. Report*, 1896, p. 538), on two steels, one of which was much milder than the other, gave values of E which are lower than those quoted above and are very nearly the same for the milder as for the higher carbon steel. The following are the figures, those for E being the means obtained by several observers with extensometers of various types:

Breaking strength tons per sq. inch	Yield-point tons per sq. inch	Ultimate extension or 8 inches per cent.	E tons per sq. inch
23·4	16·0	32	13190
35·6	20·4	24·5	13250

Mild steel plates have a shearing strength of 24 to 26 tons, and do not exhibit the same weakness in regard to shearing along a plane parallel to their faces which is observed in wrought-iron.

The modulus of rigidity C was found by Bauschinger to vary irregularly, in the series of Bessemer steels referred to above, from 5,320 to 5,670 tons per square inch. Like Young's modulus it has no obvious relation to the hardness or softness of the steel. In another series of tests (of Siemens steel) the mean value of E was 13,360, and that of C was 5,310.

Even the mildest steel when quenched in oil or water from a bright red heat shows some increase of strength, with some reduction in ultimate elongation and raising of the elastic limit. In less mild steels these effects are very marked, and when the percentage of carbon exceeds 0·5 per cent. the process of hardening by quenching deprives the steel of almost all its capability of drawing out before rupture.

Steel castings, while generally much stronger than iron castings, are less strong and decidedly less ductile than steel on which work has been done by forging or rolling. The tensile strength is often from 15 to 20 tons per square inch, sometimes as much as 25 tons

or even more. The extension before rupture is usually less than 5 per cent.

Many special steels are manufactured in which the iron is alloyed with other constituents in addition to small quantities of carbon and manganese. Nickel, aluminium, chromium, tungsten, molybdenum are among the metals used for this purpose. The effects of various proportions of nickel have been particularly studied by Mr Hadfield, who has shown that the addition of 5 or even 7 per cent. of that metal produces a steel which combines a high breaking load with much elongation and contraction of area at fracture*. The addition of nickel, in quantities even so small as 3 per cent., to steel containing 0.2 per cent. or so of carbon is highly advantageous in raising the breaking strength and the elastic limit. Most nickel steels are characterised by having a relatively high elastic limit, and this feature should make them specially suitable in cases where considerable amounts of alternating stress have to be borne.

* *Min. Proc. Inst. C. E.* vol. CXXXVIII, 1899. See also papers by D. H. Browne, *American Inst. of Mining Engineers*, 1800, and W. F. J. Porter, *Engineering and Mining Journal*, vol. LXXII, p. 282.

CHAPTER V.

UNIFORM AND UNIFORMLY-VARYING DISTRIBUTIONS OF STRESS.

77. **Use of the Stress Figure to represent a Stress distributed over a Surface.** A stress distributed over any plane surface AB (fig. 45), such as an imaginary cross-section of a

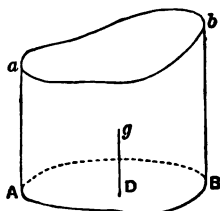

Fig. 45.

strained piece, may be represented by setting up ordinates Aa , Bb , etc., from points on the surface, the length of each ordinate being chosen so that it represents to scale the intensity of the stress at the corresponding point of the surface. In this way an ideal solid figure is constructed, which may be called the stress figure. Its height exhibits the distribution of stress over the surface which forms its base. The volume of the stress figure represents the total amount of the distributed stress. A line drawn from g the centre of gravity of the stress figure parallel to the ordinates Aa etc. determines the point D through which the resultant of the stress on the surface AB acts. This point is called the centre of stress for the surface AB .

78. **Uniformly distributed Stress.** When the stress is uniformly distributed over the surface, in other words, when its intensity at all points is the same, ab is a plane surface parallel to

AB , and D is the centre of gravity of the surface AB . This is sufficiently obvious from consideration of the stress figure: it is also seen by taking moments about any axis YY in the plane of

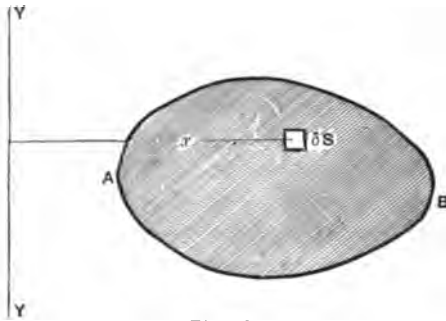

Fig. 46.

AB . Let δS be an element of the surface AB and let x be its distance from the assumed axis. Then the moment of the stress on the element δS is

$$p\delta S \cdot x,$$

and the moment of the whole stress, being the sum of the moments for all the elements, is

$$\Sigma p\delta S \cdot x,$$

or

$$p\Sigma x\delta S,$$

since in this case the intensity p is by assumption uniform.

The resultant of the stress

$$P = \Sigma p\delta S = pS,$$

where S is the area of the surface. To produce the same moment this resultant must act at distance x_r , such that

$$P \cdot x_r = p\Sigma x\delta S.$$

Hence

$$x_r = \frac{p\Sigma x\delta S}{pS} = \frac{\Sigma x\delta S}{S},$$

which is also the equation for the distance of the centre of gravity of the surface from the assumed axis.

Thus, for example, if the stressed piece is a tie-rod of uniform section, in which the distribution of stress is known to be uniform, the resultant pull must act along the axis of the rod, namely, along the line which cuts each cross-section in its centre of gravity. For brevity we may speak of this as an axial pull.

It does not however follow that an axial pull will necessarily produce a uniformly distributed stress. Other distributions of stress which will serve to bring the resultant into the line of the axis can readily be imagined: in particular the resultant will be axial if the distribution is symmetrical about the axis however much it may vary from point to point along radial lines. The question is one of much practical importance, Under what conditions (if any) will an axially applied load produce a uniformly distributed stress?

Consider a tie-rod such as that sketched in fig. 47, in which there are variations of section, and suppose the pull to act along the axis. It is clear that at a section AB near the fastening no approach to uniformity in the distribution of the stress can be expected. The central part of that section, lying as it does directly under the pin hole, bears but little of the load: nearly all is borne by the outer portions. Again, on the section CD , near a place where the area suddenly changes, the central portion has to bear nearly all the load. Or again, on EF the intensity is greater near the edges than in the middle. But as we recede from these exceptional places, advancing along parts of the bar where the section is uniform, we find a more and more close approach to uniformity in the stress, and at sections such as GH or JK the variation is probably slight. The strains to which the variable stress gives rise on such sections as AB or CD tend to equalize the action on neighbouring layers. Thus, for example, when the central part of CD is more pulled than the sides the greater stretching of the material in the centre there produces a shear which makes the lines along which the pull acts spread out, in sections above CD , into the portions of material at the sides.

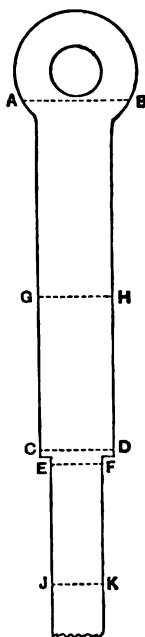

Fig. 47.

This equalizing effect of the strain occurs, to a greatly increased degree, when the elastic limit is exceeded. In a plastic material especially, like mild steel or good wrought-iron, the flow of the material in those places where the stress first passes the yield-point tends to relieve these of some of their excess of stress

and to throw a larger proportion on other parts of the section. In the testing of non-plastic metal there is some difficulty in getting a fair test, because the inequalities of distribution which necessarily exist in the neighbourhood of the grips are apt to cause fracture to occur there; but in the testing of plastic metal this difficulty does not present itself for the reason just stated, and fracture tends to take place where the section is most free to contract, namely, at or about the middle of the clear length.

Even however for stresses lying within the elastic limit the equalizing effect of the strains is so considerable that for the purpose of engineering calculations it is generally justifiable to assume that an axially applied load produces a practically uniform distribution of stress, except at or near shoulders, nicks, holes, and other places where a change of section is found. It is taken for granted in this statement that the piece is in a state of ease before the load is applied.

Subject, then, to these reservations it is usual to assume that any load P applied axially to a piece whose area of section is S will produce a stress the intensity of which may be taken as equal to $\frac{P}{S}$ at all points of the section, to a degree of approximation sufficient in calculations relating to the strength of the piece.

79. Uniformly-varying Stress. When the top of the stress figure (§ 77) is a plane inclined to the plane of the surface on which the stress acts, the stress is described as uniformly-varying. The intensity of the stress is then proportional at any point to the distance of that point from a certain line in the plane of the surface, namely, the line in which the top and bottom planes

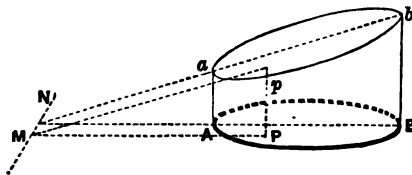

Fig. 48.

of the stress figure meet when produced if necessary. Uniformly-varying stress is illustrated in fig. 48. There MN is the line in which the plane of the stressed surface AB is met by the upper

bounding plane of the stress figure. This line is called the Neutral Axis of the uniformly-varying stress. It lies at right angles to the line AB which is assumed to be the direction along which the intensity of stress varies most rapidly. There is no variation in direction parallel to the neutral axis. The intensity of stress p at any point may be written

$$p = ax,$$

where x is the distance of the point from MN and a is the rate of variation of the stress in the direction of the line AB : in other words, a is the amount by which p increases per unit of length in the direction of AB .

Uniformly-varying stress is practically important because it occurs (for stresses within the elastic limit) in a bent beam, in a tie-rod when subjected to non-axial pull, and in a long strut or column, even when the push is originally axial, after the column has become bent so that the axis no longer coincides with the direction of the resultant thrust. The stress in beams and in struts will be considered in some detail later. Another example of uniformly-varying stress is found in a masonry pier or arch where the line of resultant thrust does not pass through the centre of gravity of the joint or section over which thrust is distributed.

It is obvious from consideration of the stress figure that in a uniformly-varying stress the resultant falls to one side of the centre of gravity of the stressed surface: in other words, the resultant is non-axial. And subject to qualifications similar to those which have been explained in dealing with uniformly distributed stress, the converse is approximately true for stresses lying within the elastic limit. That is to say, a non-axially applied load may be taken as giving rise to a stress which approximates more and more nearly to a uniformly-varying distribution the further the section dealt with is from any place where the distribution is disturbed by shoulders or holes or any such alterations in the form of the section. Thus, for example, a long tie-rod of uniform section, the fastenings of which lie excentrically so that the pull is non-axial, will have a stress which to all intents and purposes is uniformly-varying except near the fastenings. The stress in a loaded hook is another example: there the resultant passes so far from the centre of the section that

while the inner edge is in tension, the outer edge is in compression.

80. Uniformly-varying Stress forming a Couple. When the neutral axis MN (fig. 48) of a uniformly-varying stress lies, as in that figure, outside of the stressed surface, all parts of the surface are exposed to stress of one sign. The neutral axis may however lie within the surface, and it then divides the surface into two parts, on one of which there is pull and on the other there is push. A particular case of much practical interest occurs when the neutral axis passes through the centre of gravity of the stressed surface. The whole amount of the pull on one side of the neutral axis is then equal to the whole amount of the push on the other side: the resultant of the stress is not a single force but a *couple*. For the quantity $\sum ax\delta S$ has the same value over the positive region lying on one side of an axis through the centre of gravity as it has over the negative region on the other side of the same axis: multiply it by the constant a expressing the rate of variation of the stress and we have equal values of $\sum ax\delta S$, or $\sum p\delta S$, when summation is made separately on the positive and negative sides.

Such a couple stress is represented graphically in fig. 49, where

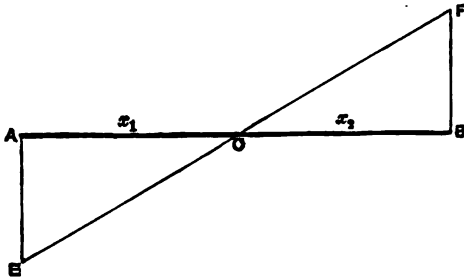

Fig. 49.

AB is a side elevation of the plane surface on which the stress acts, the direction of AB being that along which the stress varies. The neutral axis passes at right angles to AB through C , which is the centre of gravity of the stressed surface. The volume of the wedge ACE , representing in the stress figure the negative part of the stress, is equal to that of the wedge BCF , which represents the positive part of the stress. The greatest intensity of negative stress p_1 occurs at A , and the greatest intensity of positive stress

p_2 occurs at B . Calling x_1 and x_2 the distances of A and B respectively from the neutral axis through C we have

$$a = \frac{p_1}{x_1} = \frac{p_2}{x_2}.$$

To find the moment M of the couple we have to find the sum of the moments of all the elements, in other words, to integrate $x \cdot p dS$ over the whole surface:

$$\begin{aligned} M &= \int x p dS \\ &= a \int x^2 dS = aI, \end{aligned}$$

where I is the moment of inertia of the surface about the neutral axis through C . This may also be written

$$M = \frac{p_1 I}{x_1} = \frac{p_2 I}{x_2}.$$

81. Analysis of any Uniformly-varying Stress into a uniform stress and a couple. A stress such as that shown in fig. 48 or fig. 50 by the figure $AabB$ may evidently be regarded as

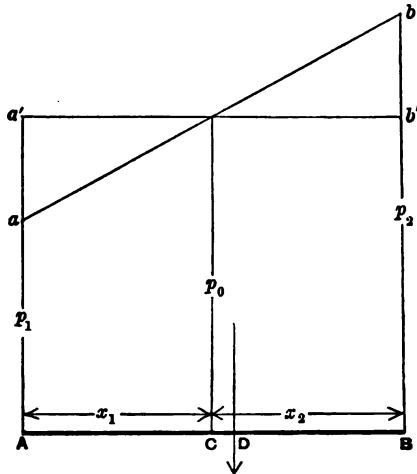

Fig. 50.

made up of a uniformly distributed stress $Aa'b'B$ together with a uniformly-varying stress whose resultant is a couple, namely, $aa'b'b$. The intensity of the uniform component, p_0 , is the intensity which the given stress has at the centre of gravity of the stressed surface. The resultant is equal to $p_0 S$, S being the area

of the surface, and it acts at such a distance x_r from C that its moment about C is equal to the moment of the couple component $aa'b'b$.

Hence to find x_r which is the distance of D , the centre of stress, from C we have

$$p_0 S \cdot x_r = aI,$$

where a is, as before, the rate of variation of the stress, namely, $\frac{p_0 - p_1}{x_1}$ or $\frac{p_2 - p_0}{x_2}$ or $\frac{p_2 - p_1}{x_1 + x_2}$, and I is the moment of inertia of the surface about an axis through C perpendicular to the direction AB along which the stress varies.

The equation
$$x_r = \frac{aI}{p_0 S} = \frac{(p_2 - p_1) I}{(x_1 + x_2) p_0 S}$$

allows the position of the resultant to be found when the stress is specified by giving the extreme intensities p_1 and p_2 . If however the position of the resultant is given, the extreme intensities are found thus:

$$p_0 S x_r = aI = \frac{(p_0 - p_1) I}{x_1},$$

hence
$$p_1 = p_0 \left(1 - \frac{S x_r x_1}{I} \right).$$

Similarly
$$p_2 = p_0 \left(1 + \frac{S x_r x_2}{I} \right).$$

82. Extent to which Stress may be Non-axial without reversing its sign at the edge of the stressed surface. The amount of which the resultant of a uniformly-varying stress may deviate from the centre of the stressed surface without reversing the sign of the stress on any part of the surface is found by writing

$$p_1 = 0,$$

the condition for which is that $S x_r x_1 = I$, or

$$x_r = \frac{I}{S x_1}.$$

Taking the particular case of a circular surface (radius r) we have $I = \frac{\pi r^4}{4}$, $S = \pi r^2$, and $x_1 = r$: hence $x_r = \frac{r}{4}$.

The stress will therefore have the same sign over a circular surface provided the resultant does not deviate from the centre by more than one-fourth of the radius.

In a rectangular surface such as a joint in masonry a similar calculation shows that the deviation may amount to one-sixth of the width of the surface without causing the stress to reverse its sign at the opposite edge. Hence the rule is sometimes followed in the design of masonry arches, of keeping the resultant thrust between neighbouring blocks within the middle third of the joint, in order that no part of the joint may be exposed to tensile stress.

In a joint formed without cement, or in one where the cement has become ineffective in offering resistance to pull, the consequence of allowing the resultant to deviate beyond the limit of the middle third would simply be to put a part of the joint out of action. That is to say, on the off side of the joint there would be, over a certain area, no stress at all, and on the remainder there would be compression, distributed in a uniformly-varying manner. The case in question is illustrated in fig. 51. From *A* to *E* there

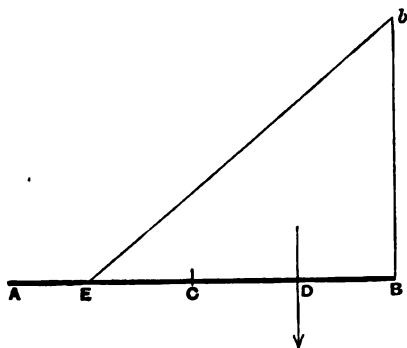

Fig. 51.

is no stress, the point *E* being found from the consideration that *EB* is (in a rectangular joint) three times the distance of *D*, the centre of stress, from *B*. In masonry piers and retaining walls it is by no means uncommon to find the resultant passing further from the centre than the middle third.

83. Simple Bending. The stresses which are produced in a beam by the application of any system of loads will be con-

sidered in the next chapter, but we may notice here a specially simple case in which the stress is of the kind illustrated by fig. 49.

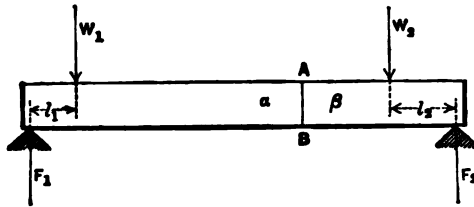

Fig. 52.

Let a beam be loaded as in fig. 52 with loads W_1 , W_2 , applied at points whose distances from the supports are l_1 and l_2 , and let

$$W_1 l_1 = W_2 l_2.$$

Then the reactions at the supports, F_1 and F_2 , are respectively equal to W_1 and W_2 . Consider the stress in any vertical section AB of the beam, taken between the points of application of W_1 and W_2 . The beam is divided by such a section into two portions α and β . The only external forces acting on β are the couple formed by W_2 and F_2 , and these must be balanced by the forces which α exerts against β in consequence of the stress at the section AB . In other words, the stress has the character of a couple, whose moment is $W_2 l_2$. We might have got the same result by considering the equilibrium of the portion α . The only external forces acting on it are the couple made up of W_1 and F_1 , and these are balanced by the forces which β exerts against α at the section: hence the stress at the section is a couple whose moment is $W_1 l_1$ —a result which is in agreement with that just arrived at, since

$$W_1 l_1 = W_2 l_2.$$

The moment of the stress on the section is called the Bending Moment. The bending moment is in this case the same for all sections lying between W_1 and W_2 .

If the stress be within the elastic limit it will be distributed in the uniformly-varying manner illustrated in fig. 53, with the neutral axis passing horizontally through the centre of gravity of the section. Calling y_1 and y_2 the distances of the top and bottom

respectively from the neutral axis, we have at the top the greatest intensity of compressive stress

$$p_1 = \frac{My_1}{I},$$

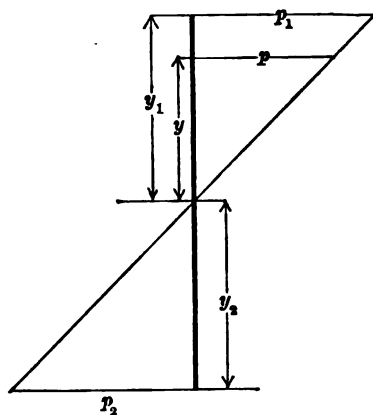

Fig. 53.

and at the bottom the greatest intensity of tensile stress

$$p_2 = \frac{My_2}{I},$$

where M is the bending moment and I is the moment of inertia of the section about the neutral axis. The intensity at any point, distant y from the neutral axis, is

$$p = \frac{My}{I}.$$

84. Influence of Bending beyond the Elastic Limit on the Distribution of the Stress. The assumption made in the last paragraph, that a bending moment gives rise to a uniformly-varying distribution of stress applies only when the material is homogeneous and when the greatest intensity of stress falls below the elastic limit. Hooke's Law is supposed to be true for all parts of the beam.

If, however, the bending moment be increased, non-elastic strain will begin as soon as either p_1 or p_2 exceeds the corresponding limit of elasticity. The distribution of the stress will then be modified. The outer layers of the beam are taking

permanent set while the inner layers are still following Hooke's Law. As a simple instance it will suffice to consider in a general way the case of a material which is strictly elastic up to a certain limit of stress, and then so plastic that any small addition to the stress produces a relatively very large amount of strain—a case not far from being realized in good wrought-iron or mild steel. When a beam of such material is overstrained the diagram exhibiting the distribution of stress will take a form generally resembling that sketched in fig. 54 or fig. 55. In fig. 54 it is

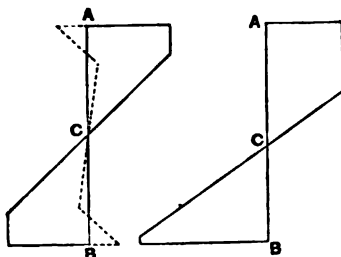

Fig. 54.

Fig. 55.

assumed that the elastic limit is the same for tension as for compression, with the effect that the distribution remains symmetrical about the original neutral axis. In fig. 55, on the other hand, it is assumed that the elastic limit is lower for compression than for extension, in consequence of which the neutral axis shifts towards the tension side when the beam becomes overstrained.

When the overstrained beam is relieved from external load it is left in a state of internal stress, the general character of which (for the case of fig. 54) is indicated by the dotted lines in that figure. This internal stress satisfies the condition that its sum and also its moment vanish over the section as a whole.

85. Modulus of Rupture. In consequence of the action which is illustrated, in a somewhat crude manner, by figs. 54 and 55, the bending moment M_1 which will break a beam cannot be calculated from the ultimate tensile strength f_t or from the ultimate compressive strength f_c by using the formula

$$M_1 = \frac{f_c I}{y_1} \text{ or } M_1 = \frac{f_t I}{y_2},$$

because the distribution of stress assumed in finding this relation

between bending moment and stress ceases to exist as soon as overstraining begins.

But when experiments are made on the ultimate strength of bars to resist bending, it is not unusual to apply a formula of this form to calculate an imaginary stress f which receives the name of the Modulus of Transverse Rupture. Let the section be such that $y_1 = y_2$. Then the modulus of transverse rupture is defined as

$$f = \frac{M_1 y_1}{I},$$

where M_1 is the value to which the bending moment has to be raised in order to break the bar.

This mode of stating the results of experiments on transverse strength is unsatisfactory, inasmuch as the modulus of rupture thus determined will vary in beams of the same material having different forms of section. When a plastic material in which the tensile and compressive strengths f_t and f_c are equal is tested in the form of an I beam in which the top and bottom flanges form nearly the whole of the section, it will have a modulus of rupture not far from equal to f_t or f_c . On the other hand, if the material be tested in the form of a rectangular bar, the modulus of rupture may approach a value one and a half times as great. For in the latter case the distribution of stress may approach an ultimate condition in which the lower half of the section is in uniform tension f_t and the upper half is in uniform compression of the same intensity. The moment of the stress is then equal to $\frac{1}{2} f_t b h^2$ where b is the breadth and h the depth of the section, while by definition of the modulus of rupture f we have

$$M = \frac{fI}{y_1} = \frac{1}{2} f b h^2.$$

Values of the modulus of transverse rupture are generally to be understood as referring to bars of rectangular section.

In a material such as cast-iron, whose tensile and compressive strengths are very different, the modulus of rupture is found to differ widely from either of these strengths. Experiments on the cross-breaking of rectangular bars of cast-iron generally give values of the modulus of rupture ranging from 14 to 20 tons per square inch, or fully double the values which are found in tests of tensile strength.

CHAPTER VI.

STRESS IN BEAMS.

86. Character of the Stress in Beams. In general the loads, as well as the supporting forces, applied to a beam act at right-angles to the beam's length. In the special case already considered in § 83 the stress at any section is a bending couple simply: in the more general case is a bending couple together with a shearing stress in the plane of the section.

Imagine a beam loaded in any manner. Let HK (fig. 56) be

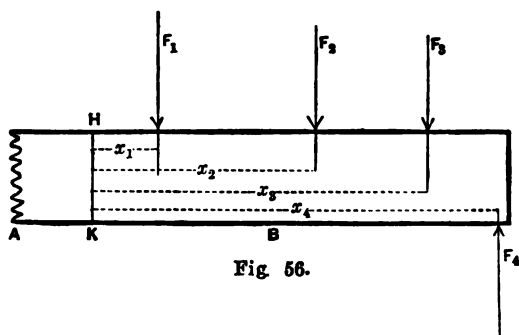

Fig. 56.

any cross-section. Between the two parts A and B into which this section divides the beam there is a stress, the amount and character of which are to be found by considering the equilibrium of either portion A or B . The portion B , for example, is in equilibrium and therefore the loads and supporting force applied to it, namely, F_1 , F_2 , F_3 , F_4 , are balanced by the forces which A exerts against B in consequence of the state of stress which exists at the section HK . The system of applied forces F_1 , F_2 , etc., may be resolved into a single force and a single couple, by referring

each force in turn to the plane of the section. Thus F_1 acting where it does act is equivalent to an equal and parallel force acting at HK together with a couple whose moment is equal to F_1x_1 , where x_1 is the distance of the force from the section. Similarly F_2 is equivalent to a force equal and parallel to F_2 acting at HK together with a couple whose moment is F_2x_2 , and so on. Hence the system of applied forces as a whole is equivalent to a couple whose moment is

$$\Sigma Fx$$

and to a force, in the plane of HK , and parallel to the applied forces, equal to

$$\Sigma F.$$

The former constitutes the Bending Moment at the section: the latter constitutes the Shearing Force.

In other words, the stress on HK must be such as to equilibrate first a couple whose moment is ΣFx and second a force ΣF tending to shear B from A . In these summations regard must of course be had to the sign of each applied force: in the case sketched, for example, the sign of F_1 is opposite to that of the other forces.

We conclude then that the stress on any section of the beam may be regarded as due to a bending moment M equal to the sum of the moments (about the section) of the externally applied forces on one side of the section (ΣFx), and a shearing force equal to the sum of the forces on one side of the section. It is a matter of convenience only whether the forces on B or those on A be considered in reckoning the bending moment and the shearing force at the section which separates A from B .

The bending moment causes (for action within the elastic limit) a uniformly-varying normal stress of the kind described in § 83. The shearing force causes a shearing stress distributed over the plane of section in a manner which will be discussed later. This shearing stress in the plane of the section is (by § 12) necessarily accompanied by an equal intensity of shearing stress in horizontal planes parallel to the length of the beam.

87. Stress due to Bending Moment. The stress due to the bending moment is the thing chiefly to be considered in practical problems relating to the strength of beams. It consists,

in an ordinary beam, of longitudinal push in filaments above the neutral axis and longitudinal pull in filaments below the neutral axis. In a cantilever, which tends to "hog" instead of "sag" under the action of the loads, the pull is on the upper and the push on the lower side: the bending moment is then opposite in sign to the bending moment of a beam supported at both ends and loaded at intermediate points.

Whether positive or negative in sign, the bending moment produces (for stresses to which Hooke's Law applies) a distribution of stress of the kind sketched in fig. 53, with a neutral axis at the centre of gravity of the section. The intensity p , at any distance y from the neutral axis is, by § 83,

$$p = \frac{My}{I},$$

where M is the bending moment and I is the moment of inertia of the section about the neutral axis. The greatest intensities of pull and push occur at the top and bottom edges, their values being

$$p_1 = \frac{My_1}{I} \quad \text{and} \quad p_2 = \frac{My_2}{I}.$$

88. Particular Cases. One or two examples may be useful. Suppose the section of the beam to be a rectangle, of width b and depth h , and to stand with the side h vertical. Then

$$I = \frac{bh^3}{12}, \quad y_1 = y_2 = \frac{h}{2}$$

and

$$p_1 = p_2 = \frac{6M}{bh^2} = \frac{6M}{Sh},$$

where S is the area of the section.

The advantage, in point of economy of material, which is gained by using a deep and narrow section is obvious. The greatest stress in a rectangular beam varies inversely as h for a given bending moment when S is constant.

In a bar of square section set with its diagonals horizontal and vertical, the moment of inertia I has the same value as if the sides were horizontal and vertical, namely, $\frac{b^4}{12}$, where b is the

length of each side. Hence p_1 for a given bending moment is greater in the ratio in which y_1 is greater, namely, in the ratio $\sqrt{2}:1$,

$$p_1 = p_2 = \frac{6\sqrt{2} \cdot M}{Sb}.$$

In a solid circular section of diameter d , $I = \frac{\pi d^4}{64}$ and

$$p_1 = p_2 = \frac{32M}{\pi d^3} = \frac{8M}{Sd}.$$

If the section is a hollow circle, like that of a bicycle tube, in which the thickness is small compared with the diameter, I approaches the limiting value $\frac{Sd^3}{8}$, and in the limit, when the thickness is relatively indefinitely small,

$$p_1 = p_2 = \frac{4M}{Sd}.$$

89. Beam with Flanges and Web. A more advantageous disposal of the material is arrived at, in respect of bending strength, when it is concentrated at the places where the stress is greatest, namely, at the top and bottom. Hence in the most usual form a beam consists of two *flanges* held apart by a thin *web* or by bracing equivalent to a web. The function of the web is, as will be shown later, to take the shearing force. The bending moment is borne mainly by the flanges, one of which is in tension and the other in compression; and if the depth of each flange is small in comparison with the depth of the beam, the intensity of the stress is nearly uniform over the whole of each flange, at any section.

Girders of this kind are formed by rolling solid metal with an **I** section, or are built up of plates, or are made by combining separate members to form frames. In some cases the beam takes a box-shaped section through the use of two webs instead of one. Often the strength to resist bending moment is calculated with reference to the flanges alone, the (generally small) addition to the bending strength which the web affords being left out of account.

In that case the relation of the bending moment to the stress in the flanges may be expressed simply as follows. Let S_1, S_2 be the area of the flanges, p_1, p_2 the intensities of stress on them, and h the height reckoned from the middle of one flange area to the

middle of the other. Then, neglecting the small variation of p over each flange,

$$M = p_1 S_1 h = p_2 S_2 h,$$

and consequently

$$p_1 = \frac{M}{S_1 h}, \quad p_2 = \frac{M}{S_2 h}.$$

It is clear that the greatest economy of material can be secured only when the sectional areas of the tension and compression flanges are made inversely proportional to the tensile and compression strength, so that $S_t f_t$ may be equal to $S_c f_c$. In rolled beams of wrought-iron and steel and also in plate beams of these metals both flanges are usually of the same sectional area, but in a cast-iron beam a section such as that shown in fig. 57 would be

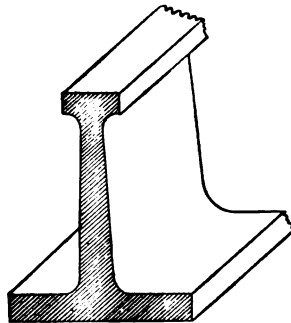

Fig. 57.

suitable, with a relatively large tension flange, the ratio of the two strengths being fully six to one. In a cast-iron beam the web is necessarily of considerable thickness and cannot properly be left out of account in reckoning the bending strength.

90. Variation of Bending Moment and Shearing Force from point to point along a Beam. Diagrams of Bending Moment and Shearing Force. The bending moment and the shearing force in general vary from point to point along a beam, and they are conveniently shown by setting up ordinates the lengths of which represent the values of these quantities, to any convenient scale, on a base line representing the length of the beam. A few examples of such diagrams may be given, and the student will find it a useful exercise to draw others for himself.

1. Single load W at the centre of the span :—

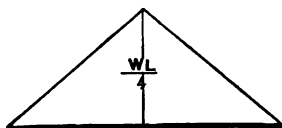
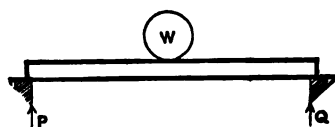

Fig. 58.

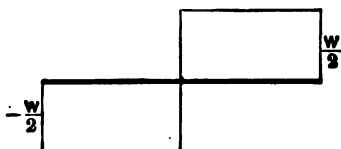

Fig. 59.

Calling P and Q the reactions at the ends, we have $P = Q = \frac{1}{2} W$.

Let L be the span and x the distance of any section from the end P , then, for the moment at a section between P and W ,

$$M_x = Px,$$

and for the shearing force

$$F_x = P = \frac{1}{2} W.$$

For a section between W and Q the bending moment is $Q(L - x)$, and the shearing force is equal to Q or $\frac{1}{2} W$.

The maximum bending moment is at the centre and its value is $\frac{PL}{2}$ or $\frac{WL}{4}$.

The diagrams of bending moment and shearing force are sketched in figs. 58 and 59 respectively. We shall distinguish a shearing force as positive when it tends to shear the right-hand portion of the beam up. With this convention the shearing force is positive on the right-hand half of the beam, and negative on the left-hand half. It changes from $+\frac{W}{2}$ to $-\frac{W}{2}$ at the place where the load is applied.

This abrupt change of the shearing force at the place where the load is applied must not be misunderstood to mean that there can be two different values of the shearing force at a single section. There is only one value at each section for any given distribution of load. The apparently anomalous state of things at the section under the load is due to the conventional assumption that the load is applied at a point. Any real load, however much concentrated, would be distributed over some finite length of the beam, and the change from positive to negative shearing force would be gradual over that length.

2. Single load W placed at any distance c from one end:—

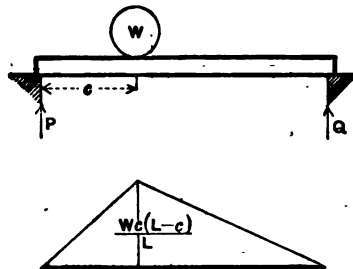

Fig. 60.

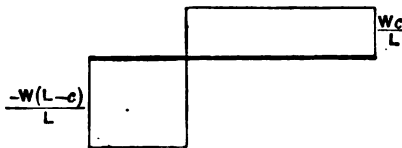

Fig. 61.

Here $Q = \frac{Wc}{L}$ and $P = \frac{W(L-c)}{L}$.

The bending moment

$$M_x = Px$$

as before, so long as x is less than c : the greatest value is reached when $x = c$ and is $\frac{Wc(L-c)}{L}$. The (negative) shearing force in the left-hand portion is equal to P , and the positive shearing force in the right-hand portion is equal to Q . The two rectangles which make up the diagram of shearing force have equal areas.

3. Two or more separate loads :—

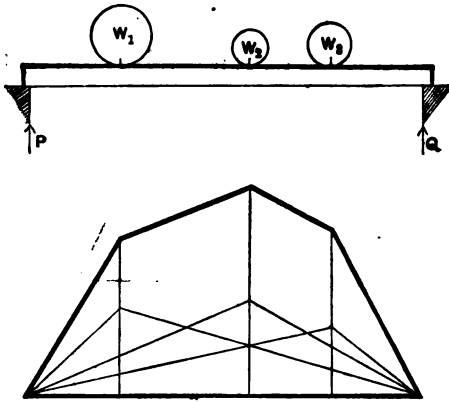

Fig. 62.

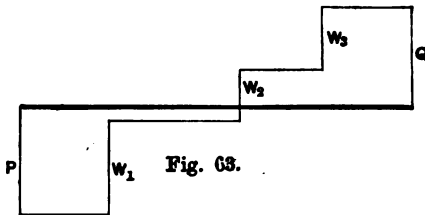

Fig. 63.

The diagram in this case may readily be drawn by drawing the diagrams for each load considered alone, in the first instance, and then combining them by adding the ordinates. The separate diagrams are shown in fig. 62 in fine lines, and the final diagram, derived from them, is shown in bolder lines. The shearing force diagram may be formed by superposition in the same way (fig. 63).

4. Continuous distribution of load, uniform per foot-run of the span :—

Let the uniform load be w per foot-run. The reaction at each pier is $\frac{1}{2}wL$. At any distance x from the left-hand end the bending moment

$$M_x = Px - wx \cdot \frac{x}{2} = \frac{w}{2} (Lx - x^2).$$

This is a maximum when $x = \frac{1}{2}L$, its value then being

$$\frac{wL^2}{8}.$$

The curve of bending moments is a parabola. (Fig. 64.)

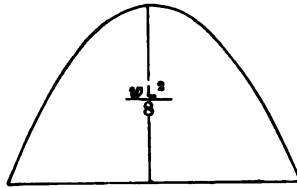

Fig. 64.

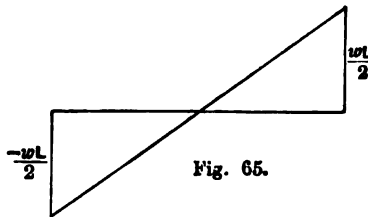

Fig. 65.

The shearing force

$$F_x = wx - P = w \left(x - \frac{L}{2} \right)$$

decreases uniformly from the value $-\frac{wL}{2}$ at the left-hand end, becomes zero at the middle, and increases uniformly to $\frac{wL}{2}$ at the other end. (Fig. 65.)

5. Beam carrying a uniformly distributed load over a part of its length only:—

Here the portions which are clear of the load are affected just as they would be if the load were concentrated at its own centre of gravity G . The straight lines pa and qb of the bending moment diagram, fig. 66, would meet, if produced, above G , and the curve from a to b is drawn by erecting on the base ab the parabola which would be the bending moment diagram of a beam AB carrying the same distributed load.

The straight line diagram $pabq$ represents the bending moment which would exist if a pair of equal loads, together equal to the

distributed load, were applied at A and B respectively. But in addition to the moment so produced, the effect of the distribution between A and B is to produce in that portion of the beam a

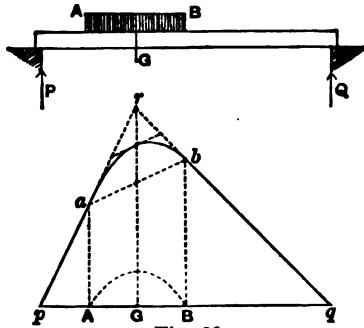

Fig. 66.

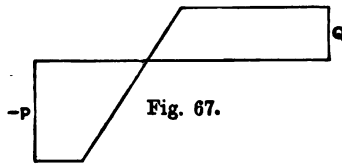

Fig. 67.

supplementary amount of bending, equal to that which the same load would produce if distributed over a beam AB resting on supports at A and B . This may be shown analytically, but it will be obvious from considerations to be brought forward in § 92 below.

The diagram of shearing force for the same case is sketched in fig. 67.

6. Beam projecting as a cantilever beyond one of its supports and loaded as sketched:—

The bending moment diagram $afcd$, fig. 68, is obtained by drawing acd which is the diagram due to the load at D alone, and abe which is due to the load at B alone and superposing them. Or, more directly, we obtain afc by setting up on the sloping base ac the ordinates of the diagram due to the load at B . To draw the shearing force diagram, fig. 69, we may calculate the reaction at C , which is the step by which the shearing force changes there, and then draw the diagram from left to right: or alternatively, sketch the diagram for the load at D alone, the reaction at C due to

The bending moment diagram for the single load is first drawn abc (fig. 70) and then that for the distributed load is drawn on the sloping base bc . Similarly for the shearing force, draw $defgh$ for the single load and superpose on it the diagram $gjhk$ for the distributed load.

91. Graphic method of finding Bending Moments. The following more purely graphic method of determining the bending moments on a beam loaded in any manner is occasionally useful. Given a beam AB carrying loads W_1, W_2 etc. at distances a_1, a_2 etc. from the support A . On an ordinate at A set off the distance $AC = QL$, L being the span, and join CB . On the line CA mark

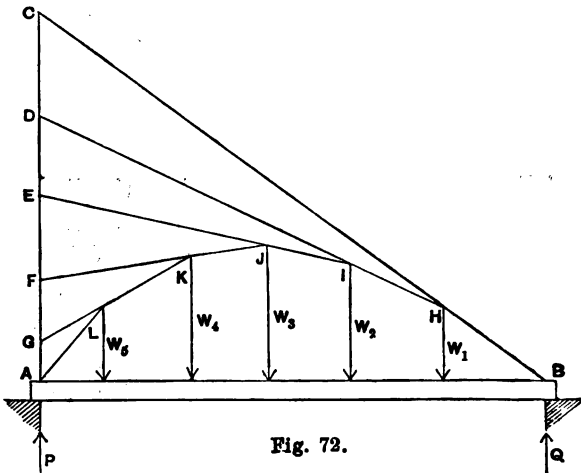

Fig. 72.

off $CD = W_1 a_1$, $DE = W_2 a_2$, $EF = W_3 a_3$ and $FG = W_4 a_4$. The remaining distance GA will be equal to $W_5 a_5$, since $\sum Wa = QL$, there being no bending moment at the pier A . Join D with H the point where CB meets the line of W_1 , D with I and so on. The line $BHIJKLA$ is the diagram of bending moments: its height evidently represents the quantity $\sum Fx$, summation being made in respect of the forces which lie to the right-hand side of any section.

92. Relation between the Bending Moment Diagram and the Funicular Polygon for the same system of Loads. The polygon formed by a hanging cord, under any system of loads,

is a diagram of bending moments for a beam similarly loaded. To prove this consider any section of the cord such as C (fig. 73). The stress there may be resolved into two components, one along

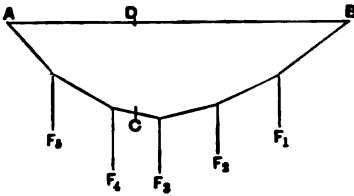

Fig. 73.

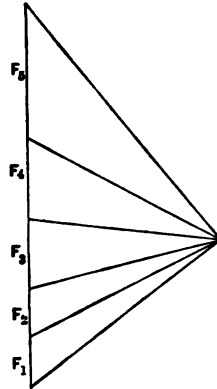

Fig. 74.

the vertical line CD and the other parallel to the line AB , which represents the span of the corresponding beam. The component parallel to AB is the same wherever the section C be taken, as is evident from consideration of the reciprocal figure. Call it H . The force exerted on the cord at B may also be resolved into a vertical part and a part along DB . Then the equilibrium of the whole right-hand portion of the cord, from C to B , requires that the moments taken about D shall balance, hence

$$H \cdot CD = \Sigma Fx,$$

where x is measured horizontally from the section, the sum being taken to the right of the section and including the vertical component of the force at B , which is the same as the reaction at the pier in the similarly loaded beam. Hence

$$CD = \frac{\Sigma Fx}{H},$$

and since H is constant CD is proportional to ΣFx , which is the bending moment on the similarly loaded beam. In this proof it is not necessary that the line AB be horizontal.

It is interesting to apply this proposition to such a case as the example no. 5 of § 90.

The continuous load from A to B (fig. 75) causes that portion of the funicular polygon to take a curved form, namely the form which

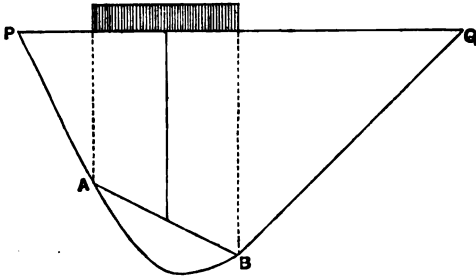

Fig. 75.

a chain whose weight represents the distributed load would take if hung from the points A and B . The straight line polygon $PABQ$ is the one which would be got by referring the load to its two extremities A and B . Hence the bending moment diagram is properly drawn (as in § 90) by drawing the straight line diagram $PABQ$ first and superposing on AB a diagram representing the bending moment which the distributed load would produce on a beam of the span AB .

93. Connection between Bending Moment and Shearing Force.

Consider two sections of a beam closely adjoining one another, separated by an indefinitely small distance δx . Call the bending moment on one M , and on the other $M + \delta M$.

We have

$$M = \Sigma Fx$$

$$M + \delta M = \Sigma F(x + \delta x),$$

the distance of each force from the second section being greater by the amount δx .

Hence

$$M + \delta M = \Sigma Fx + \delta x \Sigma F$$

and

$$\delta M = \delta x \Sigma F$$

or

$$\Sigma F = \frac{dM}{dx}.$$

That is to say, the shearing force is equal to the rate of change of the bending moment, from point to point along the beam.

Hence also, in diagrams of bending moment and shearing force, the height of the ordinate in the shearing force diagram measures the gradient of the curve in the bending moment diagram, and the area enclosed by the curve in the shearing force diagram, between any two points of the span, measures the difference between the bending moments at these two points.

If, for instance, we take two points on the beam where the bending moments are equal, the shearing force line between these points must enclose equal positive and negative areas. A particular case is when there is no bending moment at each of the two points. This applies, for example, to the whole length of an ordinary beam resting on two end supports, for at each support the bending moment is zero. It also applies to the whole length of an overhanging beam such as that of example no. 6 in § 90. The case of simple bending, without shearing, discussed in § 83, is found only when the bending moment is uniform. Illustrations of the relations between bending moment and shearing force diagrams will be found in the examples which have been already given.

94. Bending Moment and Shearing Force due to Moving Loads. The student should find it easy to establish the following propositions with respect to the action of moving loads on a beam supported at its ends.

The bending moment at any section due to a single moving load is greatest when the load is at the section. Its value is $\frac{Wx(L-x)}{L}$, where x is the distance from one end. The diagram of maximum bending moments is consequently a parabola; its height at the middle is $\frac{WL}{4}$.

The shearing force at any section due to a single moving load is positive when the load is approaching the section from the left, and negative when the load has passed the section. The greatest positive and negative values are found when the load is indefinitely near to the section, on each side. Their values are $\frac{Wx}{L}$ and $-\frac{W(L-x)}{L}$ respectively. The diagram of maximum shearing forces (positive and negative) is sketched in fig. 76.

The bending moment at any section due to a uniform advancing load is greatest when the beam is wholly covered.

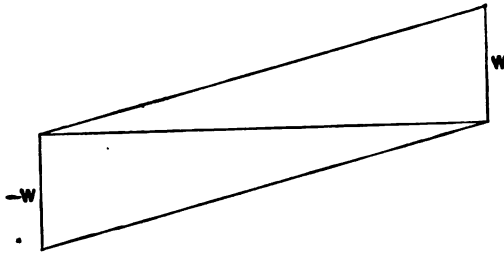

Fig. 76.

The shearing force at any section due to a uniform advancing load has its greatest positive value when the load covers the portion of the beam lying to the left of the section, and its greatest negative value when the load covers the portion of the beam lying to the right of the section. The diagram of maximum positive and negative shearing force is sketched in fig. 77. The values at any section distant x from the left-hand end are $\frac{wx^2}{2L}$ and $\frac{-w(L-x)^2}{2L}$.

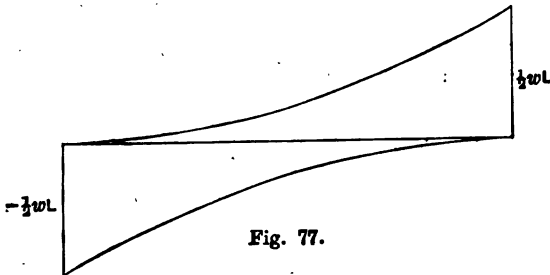

Fig. 77.

95. Distribution of Shearing Stress over the Section of a Beam. The shearing stress at any point in a vertical section of a beam is (by § 12) associated with a shearing stress of equal intensity in a horizontal plane through that point. If for instance AB and $A'B'$ are two closely neighbouring vertical sections separated by a short distance δx , the intensity of shearing stress in the section AB at the point H is the same as the intensity of shearing stress in the plane of HJ . We find the shearing stress in HJ by considering the equilibrium of the piece $AHJA'$. The normal stresses on AH and $A'J$ due to the bending moments M and $M + \delta M$ respectively differ

by an amount represented in the figure by the shaded diagram $A'JKL$, ACD being the stress figure for AC and $A'C'D'$ the

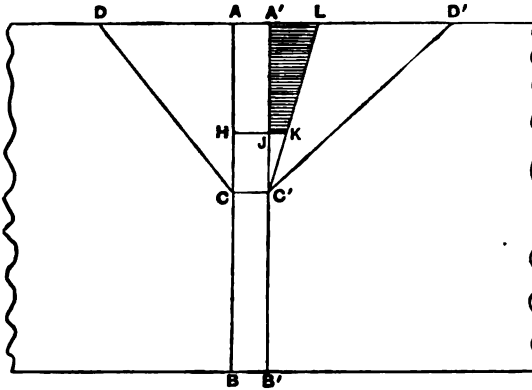

Fig. 78.

stress figure for $A'O'$, and $A'O'L$ being the difference between them. The excess of horizontal force on one side of the piece $AHJA'$ is balanced by shearing stress on the surface HJ , and the whole amount of that stress is consequently equal to the total stress represented by the shaded figure $A'JKL$.

Calling q the intensity of the shearing stress at H and ζ the width of the beam there, we have

$$q\zeta\delta x$$

for the whole shearing stress on HJ .

The intensity of the normal stress due to δM , at any height y from the neutral axis is

$$\frac{y\delta M}{I},$$

and hence the whole horizontal force represented by the shaded figure is

$$\int \frac{y\delta M}{I} z dy,$$

where z is the width of the beam at the height y , integration being performed between the limits $y = CA$ and $y = CH$.

This may be written

$$\frac{\delta M}{I} \int yz dy \text{ or } \frac{\delta M}{I} S y_0,$$

where S is the area of that part of the section which extends from A to H , and y_0 is the height of the centre of gravity of that part of the section, above the neutral axis. Equating these two expressions for the whole horizontal force on HJ we have

$$q\zeta\delta x = \frac{\delta M}{I} \cdot Sy_0,$$

from which

$$q = \frac{\delta M}{\delta x} \cdot \frac{Sy_0}{\zeta I} = \frac{FSy_0}{\zeta I},$$

where F stands for the whole shearing force at the section considered, the shearing force being (by § 93) equal to $\frac{dM}{dx}$.

It follows that the intensity of shearing stress is in general greatest at the neutral axis, and diminishes to zero at the top and bottom of the section. In the particular case of a rectangular section, the greatest intensity of shearing stress is

$$\text{max. } q = \frac{F \cdot \frac{1}{2}bh \cdot \frac{1}{4}h}{b \cdot \frac{1}{12}b^2h} = \frac{3}{2} \cdot \frac{F}{bh},$$

or one and a half times the mean intensity over the whole section. Similarly in a circular section the maximum intensity of shearing stress is $\frac{3}{2}$ of the mean.

In an I beam with wide flanges and a thin web the above expression for q shows that the intensity of shearing stress is nearly uniform over the web, and is much greater there than in the flanges in consequence of the much smaller value of the width ζ . A substantially accurate result is got, in such a case, by taking the web to bear the whole shearing force, with practically uniform distribution over the section of the web.

The same intensity of shearing stress occurs in horizontal planes in the web, and has to be reckoned with in designing the rivets or other fastenings by which the web is attached to the flanges.

96. Principal Stresses in a Beam. The foregoing analysis of the stresses in a beam, which resolves them into longitudinal pull and push, due to bending moment, along with shear in longitudinal and transverse planes, is generally sufficient in the

treatment of practical cases. If, however, it is desired to find the direction and greatest intensity of stress at any point in a beam, the planes of principal stress passing through the point have to be found. This is a particular case of the general problem of finding the principal stresses when the stresses in certain directions are known. In this case the problem is exceptionally simple, from the fact that the stresses on two planes at right angles are known, and the stress on one of these planes is wholly tangential. Let AC (fig. 79) be an indefinitely small portion of the horizontal section of a beam, on which there is only shearing stress, and let AB be an indefinitely small portion of the vertical section at the same place, on which there is shearing and normal stress. Let q be the intensity of the shearing stress, which is the same on AB and AC , and let p be the intensity of normal stress on AB : it is required to find a third plane BC , such that the stress on it is wholly normal, and to find r , the intensity of that stress. Let θ be the angle (to be determined) which BC makes with AB . Then the equilibrium of the triangular wedge ABC requires that

$$rBC \cos \theta = p \cdot AB + q \cdot AC, \quad \text{and} \quad rBC \sin \theta = q \cdot AB;$$

$$\text{or} \quad (r - p) \cos \theta = q \sin \theta, \quad \text{and} \quad r \sin \theta = q \cos \theta.$$

$$\text{Hence,} \quad q^2 = r(r - p),$$

$$\tan 2\theta = 2q/p,$$

$$r = \frac{1}{2}p \pm \sqrt{q^2 + \frac{1}{4}p^2}.$$

The positive value of r is the greater principal stress, and is of the same sign as p . The negative value is the lesser principal stress, which occurs on a plane at right angles to the former. The equation for θ gives two values corresponding to the two planes of principal stress. The greatest intensity of shearing stress occurs on the pair of planes inclined at 45° to the planes of principal stress, and its value is $\sqrt{q^2 + \frac{1}{4}p^2}$ (by § 10).

The above determination of r , the greatest intensity of stress due to the combined effect of simple bending and shearing, is of

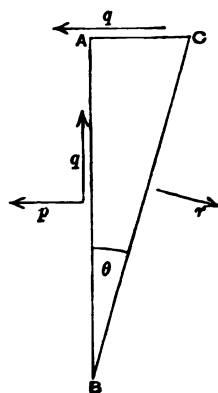

Fig. 79.

some practical importance in the case of the web of an I beam. We have seen that the web takes practically the whole shearing force, distributed over it with a nearly uniform intensity q . If there were no normal stress on a vertical section of the web, the shearing stress q would give rise to two equal principal stresses, of pull and push, each equal to q , in directions inclined at 45° to the section. But the web has further to suffer normal stress due to bending, the intensity of which at points near the flanges approximates to the intensity in the flanges themselves. Hence in these regions the greater principal stress is increased, often by a considerable amount, which may easily be calculated from the foregoing formula. What makes this specially important is the fact that one of the principal stresses is a stress of compression, which tends to make the web yield by buckling, and must be guarded against by a suitable stiffening of the web.

CHAPTER VII.

DEFLECTION OF BEAMS: CONTINUOUS BEAMS.

97. Curvature due to Bending Moment. We have to consider, in the first instance, the strain produced in beams by the action of the bending moment. The bending moment causes longitudinal strains, of extension on one side of the surface containing the neutral axes and compression on the other side. The beam, if originally straight, consequently becomes curved. In dealing with the curvature and deflection of beams we shall assume that the strains lie within the elastic limit and, as is always the case in practice, that the beam is stiff enough to keep the deflection small, and we shall in the first place exclude the case of a beam whose width is much greater than its depth.

The strain on any imaginary filament taken along the length of the beam is sensibly the same as if that filament were directly compressed or extended by itself. Since the stress at any section varies directly as the height y above or below the neutral axis, the strain also varies directly as that height. Hence two plane cross-sections, taken near together, which are parallel before straining become inclined to one another when the beam is strained, but remain plane. Let l (fig. 80) be the original distance between the two sections. At the level of the neutral axis this distance remains unaltered by the strain. At any height y above or below the neutral axis it changes by the amount δl . By Hooke's law

$$\frac{\delta l}{l} = \frac{p}{E},$$

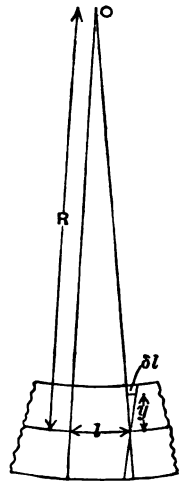

Fig. 80

where p is the mean stress, between the two sections, at the height y above the neutral axis. Further $\delta l : y = l : R$, where R is the distance from the neutral axis to the axis O where the two planes of section meet.

Hence

$$R = \frac{Ey}{p}.$$

Suppose the planes of section are taken indefinitely near together, so that the bending moment M is the same for both, R is then the *radius of curvature* of the bent beam at the place considered. Since $p = \frac{My}{I}$ we may express R also in the form

$$R = \frac{EI}{M}.$$

98. Condition of Uniform Curvature. It follows that a beam, originally straight, will bend into a circular arc if $\frac{M}{I}$ (or $\frac{p}{y}$) is constant. Practical cases in which this occurs are found (1) when a beam of uniform section is exposed to a uniform bending moment, and (2) when a beam is so designed that its depth and flange stress are both uniform. Calling the dip in the middle u_1 , we have in that case (fig. 81),

$$CE \cdot CD = CA \cdot CB,$$

$$u_1 (2R - u_1) = \left(\frac{L}{2}\right)^2,$$

from which, since u_1 is small,

$$u_1 = \frac{L^2}{8R} = \frac{LM}{8EI}.$$

The greatest slope is at each end, and is

$$i_1 = \frac{L}{2R} = \frac{LM}{2EI},$$

R being by assumption large compared with L .

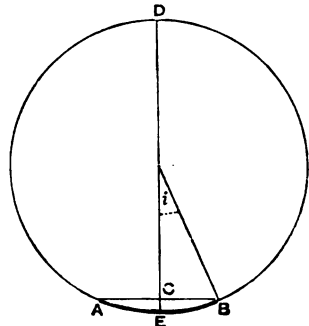

Fig. 81.

99. Relation of Curvature, Slope, and Deflection.

Denoting distance measured along the span by x , slope by i , and deflection by u , we have in all cases where the deflection is very small, so that δx may be taken as sensibly equal to δs (fig. 82),

$$\frac{\delta u}{\delta x} = i, \quad \frac{\delta x}{R} = \delta i.$$

Then the curvature

$$\frac{1}{R} = \frac{di}{dx} = \frac{d^2u}{dx^2},$$

the slope

$$i = \int \frac{1}{R} dx,$$

and the deflection, measured from below upwards,

$$u = \int i dx.$$

These equations allow us to find the slope and the deflection when R can be expressed as a function of x . The following are examples.

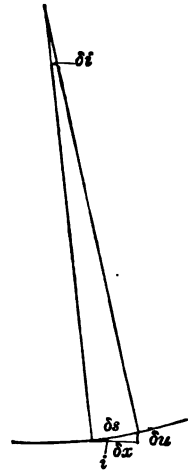

Fig. 82.

100. Examples of Slope and Deflection in Beams and Cantilevers.

(1) Beam of uniform section with uniform bending moment.

$$\frac{1}{R} = \frac{M}{EI},$$

$$i = \int \frac{1}{R} dx = \frac{M}{EI} \int dx = \frac{Mx}{EI}.$$

If we take the origin at the middle of the beam the constant of integration is zero, since $i = 0$ when $x = 0$, and the greatest slope is found by writing $x = \frac{L}{2}$, namely

$$i_1 = \frac{M}{EI} \cdot \frac{L}{2},$$

which agrees with the result got geometrically in the last paragraph.

Similarly the deflection

$$u = \int i dx = \int \frac{Mx}{EI} dx = \frac{M}{EI} \int x dx = \frac{Mx^2}{2EI},$$

and its greatest value, namely the rise of the ends of the beam above the middle, is

$$u_1 = \frac{ML^2}{8EI}$$

as before.

(2) Beam of uniform section with a single load W at the centre of the span.

Taking the origin at the centre as before, in order to make the constants of integration vanish, we have

$$M = \frac{W}{2} \left(\frac{L}{2} - x \right),$$

$$i = \int \frac{1}{R} dx = \frac{1}{EI} \int M dx = \frac{W}{2EI} \int \left(\frac{L}{2} - x \right) dx = \frac{W}{4EI} (Lx - x^2).$$

At the ends,

$$i_1 = \frac{WL^2}{16EI}.$$

To find the deflection,

$$\begin{aligned} u = \int i dx &= \frac{W}{4EI} \int (Lx - x^2) dx \\ &= \frac{Wx^2}{4EI} \left(\frac{L}{2} - \frac{x}{3} \right). \end{aligned}$$

At the ends,

$$u_1 = \frac{WL^3}{48EI}.$$

(3) Beam of uniform section with a uniformly distributed load.

Again, taking the origin at the centre,

$$M = \frac{wL^2}{8} - \frac{wx^2}{2},$$

$$\begin{aligned} i = \int \frac{1}{R} dx &= \frac{w}{2EI} \int \left(\frac{L^2}{4} - x^2 \right) dx \\ &= \frac{wx}{2EI} \left(\frac{L^2}{4} - \frac{x^2}{3} \right). \end{aligned}$$

At the ends

$$i_1 = \frac{wL^3}{24EI}.$$

To find the deflection,

$$\begin{aligned} u = \int i dx &= \frac{w}{2EI} \int \left(\frac{L^2 x}{4} - \frac{x^3}{3} \right) dx \\ &= \frac{wx^2}{8EI} \left(\frac{L^2}{2} - \frac{x^2}{3} \right). \end{aligned}$$

At the ends

$$u_1 = \frac{5wL^4}{384EI}.$$

Corresponding results for loaded cantilevers are readily found in the same way.

Both in beams supported at the ends and in cantilevers the greatest slope and greatest deflection may conveniently be expressed in the form

$$i_1 = n \frac{WL^2}{EI}, \quad u_1 = n' \frac{WL^3}{EI},$$

where W is the total load, distributed or not, and n and n' are factors depending on the uniformity or non-uniformity of the section and on the mode of loading. The following table gives numerical values of n and n' in various cases where the section is uniform. L stands for the total length of the beam or the cantilever.

	n	n'
Beam of uniform section with single load at centre	$\frac{1}{16}$	$\frac{1}{48}$
Beam of uniform section uniformly loaded	$\frac{1}{24}$	$\frac{5}{384}$
Cantilever of uniform section with single load at end	$\frac{1}{2}$	$\frac{1}{3}$
Cantilever of uniform section uniformly loaded	$\frac{1}{6}$	$\frac{1}{8}$

Similar expressions will apply in the case of beams of uniform depth and uniform strength (uniform flange stress) if we understand I to refer to the central section in the case of a beam, or to the section at the fixed end in the case of a cantilever. The curvature is, as we have seen, uniform, and the factors n and n' take the following values.

	n	n'
Beam of uniform strength and depth, with single load at centre	$\frac{1}{8}$	$\frac{1}{32}$
Beam of uniform strength and depth uniformly loaded	$\frac{1}{16}$	$\frac{1}{64}$
Cantilever of uniform strength and depth, with single load at end	1	$\frac{1}{2}$
Cantilever of uniform strength and depth uniformly loaded	$\frac{1}{2}$	$\frac{1}{4}$

The deflection due to a combination of loads may be found by summing the deflections due to the loads considered separately.

101. **Deflection of a uniform beam under a single load placed anywhere.** As a further example of the general method we may take the case of a beam of uniform section with a single load W placed at a distance a from the end P and b from the

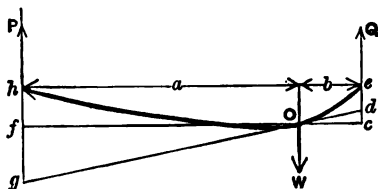

Fig. 83.

end Q . Take the place where the weight is applied as origin and consider first the portion of the beam which lies to the right. At any point in it the bending moment is $Q(b-x)$. The change of slope, in going from the origin towards the right is $\int \frac{M}{EI} dx$ or $\frac{Q}{EI} \int (b-x) dx$, and the whole slope at any point on the right is

$$i = i_0 + \frac{Q}{EI} \int_0^x (b-x) dx,$$

where i_0 is the slope at O ,

$$i = i_0 + \frac{Q}{EI} \left(bx - \frac{x^2}{2} \right).$$

The deflection, measured up from the horizontal line through O , is

$$u = i_0 x + \frac{Q}{EI} \int_0^x \left(bx - \frac{x^2}{2} \right) dx.$$

Hence the height of the end Q above the horizontal line through O , namely $cd + de$ in the figure, where the deflection of the beam is, of course, excessively exaggerated, is

$$i_0 b + \frac{Q}{EI} \cdot \frac{b^3}{3}.$$

The line gd is drawn through O in the direction of the slope of the beam at O .

Similarly the height of the end P above the horizontal line through O (namely $gh - fg$ in the figure) is

$$\frac{P}{EI} \cdot \frac{a^3}{3} - i_0 a.$$

Equating these two expressions for the deflection of O below the level of the ends of the beam we have

$$i_0(a+b) = \frac{1}{3EI}(Pa^3 - Qb^3),$$

and, substituting the value of i_0 found thus, the deflection at O is

$$\begin{aligned} u_0 &= \frac{1}{3EI} \left(Pa^3 - \frac{(Pa^3 - Qb^3)}{a+b} a \right) \\ &= \frac{Pa^3b + Qab^3}{3EI(a+b)} \\ &= \frac{Wa^3b^3}{3EI(a+b)}. \end{aligned}$$

A graphic method of solving the same problem will be found in § 104.

102. Transverse Bending. Anticlastic Curvature. Associated with the longitudinal bending of beams is a transverse bending with opposite curvature. This results from the lateral contraction of the longitudinally extended filaments and the lateral expansion of the longitudinally compressed filaments. An originally rectangular section tends to take a form like that sketched in fig. 84, the beam being one supported at its ends, so that the bending moment produces longitudinal extension below the neutral axis and longitudinal compression above it. The lateral strain being $\frac{1}{\sigma}$ of the longitudinal strain, the anticlastic or transverse curvature to which it gives rise is $\frac{1}{\sigma}$ of the longitudinal curvature, and the radius of transverse curvature is $R\sigma$.

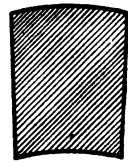

Fig. 84.

This however assumes that each filament is perfectly free to expand or contract laterally, a thing which is never more than approximately true and becomes less true the greater is the width of the beam. When a wide flat strip is bent as a beam it necessarily remains nearly flat: in other words, the horizontal lateral strain which would give rise to transverse curvature is to a

great extent prevented. As a consequence, the strip is stiffer in regard to longitudinal bending than it would be if each filament were free to take lateral strain. The case approximates to that considered in § 30, namely where lateral strain is free to take place in one direction (namely vertically), but is prevented from taking place in the other direction (horizontally). The appropriate modulus for the longitudinal strain is then

$$\frac{E\sigma^2}{\sigma^2 - 1},$$

and the radius of longitudinal curvature, instead of having the value

$$\frac{EI}{M},$$

as it has (very nearly) when the transverse dimensions of the section are small, has a value approximating to

$$\frac{EI\sigma^2}{M(\sigma^2 - 1)}.$$

The ordinary theory of bending applies only when the section is so comparatively narrow that the anticlastic bending due to lateral strain is substantially free to take place, and this holds good in most actual beams. The transverse flexure is not in general of practical importance.

103. Resilience of a Beam. The work done in bending any short portion δx of a beam is $\frac{M\delta i}{2}$ where M is the bending moment and δi is the amount by which the slope changes from one to the other end of the element of length δx . Hence the whole work done in bending the beam is

$$U = \frac{1}{2} \int M di,$$

integration being performed from end to end.

Since $\delta i = \frac{1}{R} \delta x$ and $R = \frac{EI}{M}$ we may write

$$U = \frac{1}{2} \int \frac{M^2}{EI} dx.$$

The following are particular cases: (1) Beam of uniform section

subjected to a uniform bending moment, and therefore assuming uniform curvature,

$$U = \frac{M^2 L}{2EI}.$$

Since $\frac{M}{I} = \frac{p}{y}$ this may be written

$$U = \frac{p^2 IL}{2Ey^2}.$$

And when the section is rectangular this becomes

$$U = \frac{p_1^2 hbL}{6E},$$

p_1 being the intensity of stress at the top or bottom. Thus the resilience of a rectangular bar when uniformly bent is

$$\frac{p_1^2}{6E}$$

per unit of volume, or one-third as great as the resilience of a piece uniformly stressed by a simple pull or push of the same greatest intensity p_1 .

This result might have been reached at once from the consideration that in the beam the stress varies uniformly across each half of the section from zero to p_1 and consequently the mean value of p^2 is one-third of the extreme value p_1^2 .

(2) Beam of uniform section with a single load W at the centre.

Take the origin at one end and calculate the resilience of one-half the beam :

$$\frac{U}{2} = \frac{1}{2EI} \int M^2 dx = \frac{1}{2EI} \int \left(\frac{Wx}{2} \right)^2 dx = \frac{W^2}{8EI} \left[\frac{x^3}{3} \right].$$

Hence, writing $x = \frac{L}{2}$, we have for half the beam

$$\frac{U}{2} = \frac{W^2 L^3}{192EI},$$

and the resilience of the whole beam is $\frac{W^2 L^3}{96EI}$.

This might also have been got as half the product of the load by the deflection u_1 , which is $\frac{WL^3}{48EI}$.

Expressed in terms of the greatest stress at the middle section the above expression for U becomes

$$\frac{p_1^2 IL}{6Ey_1^2}.$$

In a rectangular beam loaded at the middle this gives

$$U = \frac{p_1^2 hbL}{18E},$$

making the mean resilience per unit of volume equal to

$$\frac{p_1^2}{18E},$$

or one-ninth of the resilience of a piece uniformly stressed with the intensity p_1 .

This again is a conclusion which might be arrived at by considering that the mean value of p^2 across any section is $\frac{1}{3}p_1^2$ for that section, and that the mean value of p_1^2 along the beam is one-third of the value at the middle section. Hence the mean value of p^2 for the whole volume of the beam is one-ninth of the value of p_1^2 at the middle section.

104. Graphic method in the treatment of Deflection.
The three quantities

Curvature, $\frac{1}{R}$,

Slope, i ,

Deflection, u ,

are related to one another in the same way as the three quantities

Load per foot run, w ,

Shearing force, F ,

Bending moment, M .

For $\frac{du}{dx} = i$ and $\frac{di}{dx} = \frac{1}{R}$, while $\frac{dM}{dx} = F$ and $\frac{dF}{dx} = w$.

Hence, if we assume an imaginary load w' equal to the curvature $\frac{1}{R}$, or $\frac{M}{EI}$, the shearing force which w' would cause measures the slope due to the real load, and the bending moment which w' would cause measures the deflection due to the real load.

The problem therefore resolves itself into finding the shearing force and bending moment which would be produced by the imaginary load w' , and in practice this is in general best done by drawing the diagram of shearing force and bending moment for the imaginary load.

The method may be illustrated by an example.

In a beam of uniform section with a single load W at the middle, the imaginary load equal to the curvature is $w' = \frac{M}{EI}$.

This has its greatest value at the middle, namely $\frac{WL}{4EI}$. Its mean value is half this, and hence the reaction at each pier due to the imaginary load w' is $\frac{WL^2}{16EI}$.

The diagram of w' is sketched in fig. 85, and that of the shearing force due to w' in fig. 86. The greatest slope in the

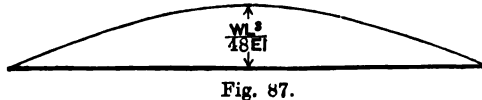
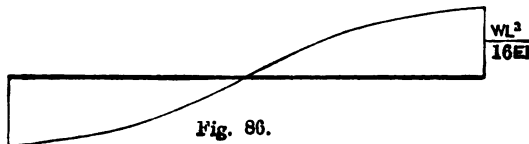

actual beam is the greatest value of the shearing force due to w' and is therefore $\frac{WL^2}{16EI}$, as was found otherwise in § 100.

The diagram of bending moment due to w' is sketched in fig. 87. At the middle of the span the value is

$$\frac{WL^2}{16EI} \cdot \frac{L}{2} - \frac{WL^2}{16EI} \cdot \frac{L}{6} = \frac{WL^3}{48EI}.$$

This measures the deflection at the centre produced by the actual load, and is in agreement with the result found in § 100.

As another example we may take the case dealt with in § 101, of a beam of uniform section carrying a single load at any point. The diagram of imaginary load w' is sketched in fig. 88. Let

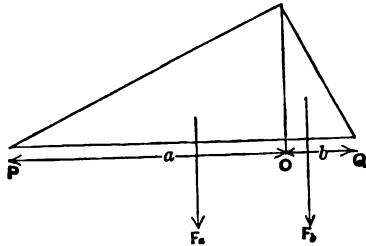

Fig. 88.

P' , Q' be the reactions due to it, and F_a , F_b be the total amounts of the imaginary load distributed over the portions a and b respectively. Then calling the reactions at the support of the actual beam P and Q as before, we have

$$\text{greatest } w' \text{ (at } O) = \frac{Pa}{EI} = \frac{Qb}{EI} = \frac{Wab}{EI(a+b)},$$

$$F_a = \frac{Pa^2}{2EI}, \quad F_b = \frac{Qb^2}{2EI},$$

$$Q = \frac{F_a \cdot \frac{2}{3}a + F_b(a + \frac{1}{3}b)}{a+b} = \frac{\frac{1}{3}Pa^2 + \frac{1}{3}Qb^2(a + \frac{1}{3}b)}{EI(a+b)}.$$

The deflection in the actual beam at O is the moment at O due to the imaginary load w' , namely

$$Q'b - F_b \cdot \frac{1}{3}b.$$

Substituting the values given above for Q' and F_b this becomes

$$\frac{Pa^2b + Qab^2}{3EI(a+b)} = \frac{Wa^2b^2}{3EI(a+b)},$$

as in § 101.

105. Additional Deflection due to Shearing. The shearing strain in a beam produces a supplementary deflection which is in general too small to be of practical account. We may examine its value in a particular case, namely that of a beam of uniform rectangular section, loaded with a weight W at the middle. The total shearing force is in this case uniform in amount along the whole length, its value being $\frac{W}{2}$ and it is distributed in the same manner at each cross section.

By § 95 its intensity q at any height y from the neutral axis is

$$q = \frac{3W \left(\frac{h^2}{4} - y^2 \right)}{h^3 b}.$$

The work done in producing the shearing strain is by § 22 $\frac{q^2}{2C}$ per unit of volume at any place. The work done in shearing is therefore

$$\int \frac{q^2}{2C} b dy$$

per unit of length of the beam. Hence the whole work done in shearing the beam is

$$U_s = \frac{Lb}{2C} \int q^2 dy = \frac{9W^2 L}{2h^3 b C} \int \left(\frac{h^2}{4} - y^2 \right)^2 dy.$$

On integrating from $y = \frac{h}{2}$ to $y = -\frac{h}{2}$ this gives

$$U_s = \frac{3W^2 L}{20hbC}.$$

The work done in bending the beam (apart from shearing) is by § 100,

$$U_b = \frac{W^2 L^3}{96EI}.$$

The total deflection at the middle, where the load is applied, must be such as to give this quantity when multiplied by half the load. Hence the deflection is

$$\frac{3WL}{10hbC} + \frac{WL^3}{48EI}.$$

The second of these terms is the deflection due to bending, without taking shear into account; the first term is the additional deflection due to shear. The ratio of the first to the second is

$$\frac{6Eh^3}{5CL^3}.$$

This shows that for any usual ratio of h to L the additional deflection due to shear is only a small fraction of the whole deflection.

The following case admits of still more simple treatment and is interesting as an example in which the shear strain may be of greater importance. Let the beam be of the **I** type, in which the shearing stress is practically all taken by the web and its intensity q over the section of the web is practically constant. With a single load W at the centre we have at all sections

$$q = \frac{W}{2A_w},$$

where A_w is the (uniform) area of section of the web. This shearing stress produces everywhere a slope supplementary to the slope produced by the longitudinal strains in bending, of the amount

$$i' = \frac{q}{C} = \frac{W}{2A_w C}.$$

Hence the supplementary deflection at the middle, where it is greatest, is

$$u' = \frac{W}{2A_w C} \cdot \frac{L}{2}.$$

The deflection due to the longitudinal strains in bending is (by § 100)

$$u = \frac{WL^3}{48EI}.$$

Taking the area of each flange to be uniform and equal to A_f we may treat I as practically equal to

$$\frac{A_f h^2}{2},$$

which makes

$$u = \frac{WL^3}{24EA_f h^2}.$$

The ratio of the shearing to the bending deflection

$$\frac{u'}{u} = \frac{6E}{C} \cdot \frac{A_f}{A_w} \cdot \frac{h^3}{L^3}.$$

As $\frac{6E}{C}$ is fully 15 in iron and steel, the shearing deflection may in this case form a considerable part of the whole, when the span is not a large multiple of the height and when the web is thin.

In the considerations which follow, relating to continuous beams, the supplementary deflection due to shearing is not taken into account.

106. Continuous Beams. A perfectly rigid beam resting on two rigid piers would be lifted off one or both of these if a third support were introduced. In a real beam the flexibility makes it possible for the load to be shared by more than two piers. A beam is said to be continuous when the number of its supports is greater than two.

As a simple case we may first consider a beam of uniform section, uniformly loaded, resting on three equidistant piers at the same level. Imagine the middle pier to be removed, leaving an ordinary beam of span $2L$. The deflection at the middle would then be (by § 100)

$$\frac{5}{32} \frac{w(2L)^4}{EI} = \frac{5}{8} \frac{wL^4}{EI}.$$

In other words, this is the distance through which the middle pier would have to be lowered in order to relieve it of all share of the load.

Now imagine the middle pier to be raised until it lifts the ends off their supports. The amount it must rise above the level would be equal to the deflection at the end of a uniformly loaded cantilever of length L , namely

$$\frac{1}{8} \frac{wL^4}{EI}.$$

The pressure on it would then be $2wL$. This pressure increases uniformly as the pier rises, from zero at a depth $\frac{5}{8} \frac{wL^4}{EI}$ below the level of the ends, to $\frac{1}{8} \frac{wL^4}{EI}$ above the level of the ends. Hence

when the middle pier is at the same level as the end piers the pressure on it is

$$\frac{\frac{5}{24}}{\frac{5}{24} + \frac{1}{8}} \cdot 2wL = \frac{5}{4}wL.$$

And the pressure on each of the end piers is consequently

$$\frac{1}{2} \left(2 - \frac{5}{4} \right) wL = \frac{3}{8}wL.$$

Another way of putting the matter is to regard the pressure F on each end pier as a single inverted load, acting on a cantilever of the length L to produce an upward deflection equal to the downward deflection which the load would produce on a cantilever of that length. The upward deflection due to F is $\frac{FL^3}{3EI}$. Equating this to the downward deflection produced by the load, namely $\frac{wL^4}{8EI}$, we have $F = \frac{3}{8}wL$.

If the middle pier were fixed at any assigned small height above or below the others it would evidently be easy to extend this treatment to find the proportion of load borne by it and by the other piers. The diagrams of shearing force and bending

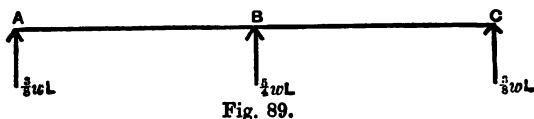

Fig. 89.

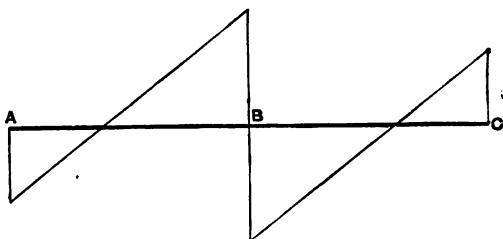

Fig. 90.

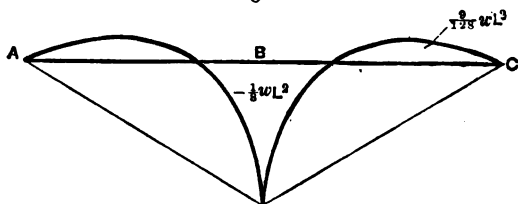

Fig. 91.

moment, when the piers are at the same level, are sketched in figs. 90 and 91. The diagram of bending moment is conveniently drawn by treating each half BC and BA as a cantilever fixed at B , and loaded with an upward force F at the end along with a uniformly distributed load w .

The points of inflection, where the bending moment is zero, are at a distance of $\frac{1}{2}L$ from the middle pier. At any distance x from the middle pier the bending moment is

$$M_x = \frac{1}{2}wL(L-x) - \frac{w(L-x)^2}{2}.$$

The greatest negative bending moment occurs over the middle pier: its value is $\frac{1}{8}wL^2$. The greatest positive bending moment occurs at points $\frac{1}{3}L$ from each end: its value is $\frac{9}{128}wL^2$.

It may be instructive to treat this example of a continuous beam in a more general way, using a method which is suitable for application to other cases:—

Let F be the (unknown) pressure on each of the end piers.

Taking the middle point as origin we have

$$\begin{aligned} M_x &= F(L-x) - \frac{w(L-x)^2}{2} \\ &= L\left(F - \frac{wL}{2}\right) - (F - wL)x - \frac{wx^2}{2}. \end{aligned}$$

The slope

$$i = \int \frac{M}{EI} dx = \frac{1}{EI} \left\{ Lx \left(F - \frac{wL}{2} \right) - (F - wL) \frac{x^2}{2} - \frac{wx^3}{6} \right\}.$$

The constant of integration vanishes, since $i = 0$ when $x = 0$.

The deflection

$$u = \int i dx = \frac{1}{EI} \left\{ L \left(F - \frac{wL}{2} \right) \frac{x^2}{2} - (F - wL) \frac{x^3}{6} - \frac{wx^4}{24} \right\}.$$

The constant of integration again vanishes, since $u = 0$ when $x = 0$.

Now if the piers are at the same level $u = 0$ when $x = L$, and hence

$$\frac{1}{2} \left(F - \frac{wL}{2} \right) - \frac{1}{6} (F - wL) - \frac{wL}{24} = 0,$$

which makes
as before.

$$F = \frac{3}{8}wL$$

The student will find it a useful exercise to apply this more general method to the case of a beam of three equal spans. He will find that each end pier bears a load of $\frac{1}{10}wL$ and each of the other two bears $\frac{1}{6}wL$.

107. Theorem of Three Moments. Whatever be the length of the spans and the mode of loading, an equation can be found connecting the moments over any three neighbouring piers. This is Clapeyron's "Theorem of Three Moments," the algebraic expression of which does much to facilitate the solution in less simple cases than the one considered above.

The theorem of three moments may be expressed in a generalised form applicable to all modes of loading, but it will suffice for our purpose to consider the case of uniform loading only.

Let A, B, C be any three consecutive piers (at the same level) in a continuous girder having any number of equal or unequal spans, uniformly loaded with a weight w per foot run. The object of the theorem is to establish an equation between the three pier moments M_A, M_B and M_C . The method we shall follow in getting the equation is to express the moment and the slope at B in two ways, by reckoning separately first from A and then from C .

Taking the origin first at A we have for any point in the span AB

$$M_x = M_A + F_A x - \frac{wx^2}{2} \dots \dots \dots (1).$$

At B , where $x = AB$

$$M_B = M_A + F_A L_{AB} - \frac{w}{2} L_{AB}^2 \dots \dots \dots (2).$$

Similarly by reckoning back towards B from C

$$M_B = M_C + F_C L_{CB} - \frac{w}{2} L_{CB}^2 \dots \dots \dots (3).$$

Returning now to equation (1), since $\frac{d^2u}{dx^2} = \frac{1}{R} = \frac{M}{EI}$, we may write that equation thus

$$EI \frac{d^2u}{dx^2} = M_A + F_A x - \frac{wx^2}{2} \dots \dots \dots (4).$$

Integrating to find the slope

$$EI \frac{du}{dx} = M_A x + F_A \frac{x^2}{2} - \frac{wx^3}{6} + C \dots \dots \dots (5),$$

where C is a constant of integration.

Integrating again to find the deflection

$$EIu = M_A \frac{x^2}{2} + F_A \frac{x^3}{6} - \frac{wx^4}{24} + Cx \dots \dots \dots (6).$$

The constant of integration is here zero, since $u = 0$ when $x = 0$.

Hence, since $u = 0$ when $x = L_{AB}$

$$0 = \frac{1}{2}M_A L_{AB}^2 + \frac{1}{6}F_A L_{AB}^3 - \frac{w}{24}L_{AB}^4 + CL_{AB}$$

from which $C = -\frac{1}{2}M_A L_{AB} - \frac{1}{6}F_A L_{AB}^2 + \frac{w}{24}L_{AB}^3 \dots \dots \dots (7).$

Writing i_B for the slope, or $\frac{du}{dx}$, at B , we have by equation (5), since x is then L_{AB} ,

$$EIi_B = M_A L_{AB} + \frac{1}{2}F_A L_{AB}^2 - \frac{1}{6}wL_{AB}^3 + C.$$

Substituting for C the value given in equation (7) we have

$$EIi_B = \frac{1}{2}M_A L_{AB} + \frac{1}{3}F_A L_{AB}^2 - \frac{w}{8}L_{AB}^3 \dots \dots \dots (8).$$

In the same way, taking C as origin and reckoning back along CB we get

$$-EIi_B = \frac{1}{2}M_C L_{CB} + \frac{1}{3}F_C L_{CB}^2 - \frac{w}{8}L_{CB}^3 \dots \dots \dots (9),$$

the negative sign coming in on account of x being reckoned negatively.

Equate these and eliminate the terms in F_A and F_C by substitution from equations (2) and (3), and we obtain an equation between the moments M_A , M_B and M_C

$$\frac{1}{2}M_A L_{AB} + M_B L_{AB} + \frac{1}{8}wL_{AB}^3 = -\frac{1}{2}M_C L_{CB} - M_B L_{CB} - \frac{1}{8}wL_{CB}^3;$$

or

$$(M_A + 2M_B) L_{AB} + (M_C + 2M_B) L_{CB} + \frac{w}{4}(L_{AB}^3 + L_{CB}^3) = 0 \dots (10).$$

This is the theorem of three moments, expressed in the comparatively simple form which applies to uniform loading. If

there are n piers it yields $n - 2$ equations and the terminal conditions supply the two more which are required for solution. Usually the terminal conditions simply are, that the moments at the first and the last pier are zero.

As an example of the use of the theorem we may first apply it to the case already treated, namely that of a continuous beam of two equal spans. Here $M_A = 0$ and $M_C = 0$. Equation (10) becomes

$$2M_B L + 2M_B L + \frac{wL^3}{2} = 0,$$

from which
$$M_B = -\frac{wL^3}{8}.$$

Then, since $M_B = F_A L - \frac{wL^3}{2}$, $F_A = \frac{3}{8}wL$, as was found in § 106.

Similarly with three equal spans the moment at each intermediate pier is readily found to be $-\frac{wL^3}{10}$, making the reactions $\frac{4}{10}wL$ at each end pier and $\frac{11}{10}wL$ at each intermediate pier.

Again, take the case of four equal spans. Here $M_A = M_E = 0$, $M_B = M_D$.

Equation (10) gives

$$4M_B + M_C = -\frac{wL^3}{2},$$

and
$$M_B + 4M_C + M_D = -\frac{wL^3}{2},$$

from which $M_C = -\frac{wL^3}{14}$ and M_B or $M_D = -\frac{3wL^3}{28}$.

The reactions at the piers are then found to be $\frac{11}{28}$, $\frac{32}{28}$, $\frac{36}{28}$, $\frac{32}{28}$ and $\frac{11}{28}$ of wL in each case*.

108. Advantages of Continuous Beams. In a continuous beam the average value of the bending moment is much less than in a series of separate beams bridging the same spans and subject to the same load, and hence, by adapting the section to the moment at each point the continuous beam may be made much

* For the graphic treatment of problems in continuous beams the student is referred to a paper by Professors Perry and Ayrton, *Proc. Roy. Soc.* 1879, and to Prof. Claxton Fidler's *Treatise on Bridge Construction*. See also Levy's *Statique Graphique*, vol. II.

lighter than the series of separate beams. But the advantage does not stop here: in the continuous beam the greatest values of the bending moments occur at and near the piers, whereas in the separate beam they occur at and near the middle of each span. Hence the heavier sections of the continuous beam are placed in positions where they are much less influential in causing bending moment. In long beams the weight of the beam itself becomes an important factor in producing bending moment: in a very long beam it is the chief factor. In such cases the advantage of continuity is specially great, on account of the concentration of weight near the piers and the comparatively light sections which are required towards the middle of each span. For short spans, where the externally applied load is the chief part of the whole load, the advantage of continuity is much less, especially when provision has to be made for moving loads. When moving loads pass over the beam the points of inflection change, and portions of the span are subjected to bending moments which change in sign as well as in amount.

The advantage of continuous beams is practically much restricted by the possibility that the supports may yield and may thereby disturb the distribution of moments. A small amount of subsidence on the part of one of the piers may seriously alter the stresses and upset estimates of strength based on the assumption that the piers are on the same level. Even small errors in construction, whether in the level of the piers or the straightness of the built beam, are not without effect.

When beams intended to be continuous have been in the first instance erected in separate spans they have of course to be connected in such a way as to secure effective continuity. Account must be taken of the flexure set up in each separate span by its own weight, and one or both of the distant ends must be lifted through a calculated distance before the near ends are joined over the pier, so that when the distant ends are let down again the moment due to the weight may be properly distributed.

109. Combination of Cantilever with Beams. In any continuous beam we might imagine the beam to be cut at each point of inflection, and the parts to be joined by a pin or other joint capable of resisting shearing force, but incapable of resisting bending moment. The stresses throughout the beam would be

unaffected by this change. We should then have a system of cantilevers projecting from the piers, united by beams between the ends of the cantilevers.

Such a combination would however be free from the objection which has just been stated. Any subsidence of a support would not affect the distribution of stresses, because the points of inflection are now fixed. Moreover, they remain fixed when the loads change and the changes of bending moment and shearing force due to moving loads are readily calculated. The combination retains the main advantage and escapes the drawbacks of simple continuity. It has been used in some of the largest modern bridges, notably by Sir B. Baker in the great bridge over the Firth of Forth.

110. Encasté Beams. An *encasté* or built-in-beam is one whose ends are secured in such a way as to prevent any change of slope from taking place at the ends. The condition is not easy to realize in practice, and may be said to be never more than approximately realized. It will suffice for our present purpose to consider a beam whose ends are fixed horizontally so that they remain horizontal when the beam bends under load (fig. 92).

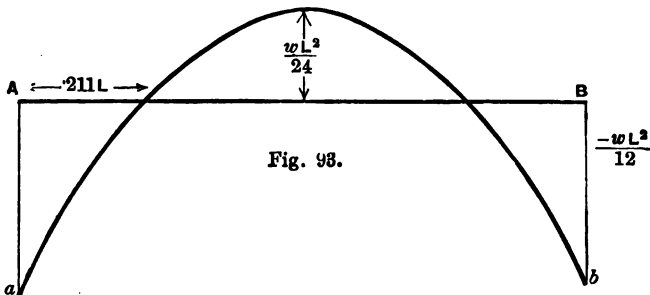
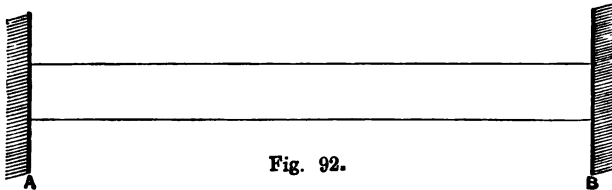

This may be regarded as equivalent to one span in a continuous beam of an indefinite number of equal spans, similarly

loaded. Over each pier such a beam would lie horizontally. Hence we may apply the Theorem of Three Moments.

Taking the case of a beam of uniform section uniformly loaded we have, in the expression of the Theorem given in § 107, $M_B = M_C = M_A$, and hence the expression becomes

$$(M_A + 2M_A)L + (M_A + 2M_A)L + \frac{w}{4}(2L^3) = 0,$$

whence
$$M_A = \frac{-wL^3}{12}.$$

This is the bending moment which must exist at each of the fixed ends to keep the beam horizontal there.

The forces which each support exerts upon the beam constitute (1) a couple whose moment is M_A and (2) a vertical reaction equal to that part of the weight which comes on each end, namely $\frac{1}{2}wL$. The first of these is the bending moment at the support, the second is the shearing force.

At any point distant x from the end the bending moment

$$M_x = M_A + \frac{1}{2}wL \cdot x - wx \cdot \frac{x}{2} = M_A + \frac{1}{2}wx(L - x),$$

the first term being due to the couple applied at the support, and the second term to the vertical reaction at the support.

Hence
$$M_x = \frac{-wL^3}{12} + \frac{wx}{2}(L - x).$$

To find the points of inflection we write $M_x = 0$, which occurs when

$$x(L - x) = \frac{L^2}{6}$$

that is, when
$$x = \frac{L}{2} \left(1 \pm \frac{1}{\sqrt{3}} \right),$$

which gives $x = 0.211L$ and $x = 0.789L$ as the distances of the two points of inflection from either support.

At the middle, where the positive bending moment is a maximum, its value is

$$M_0 = \frac{-wL^3}{12} + \frac{wL}{4} \left(L - \frac{L}{2} \right) = \frac{wL^2}{24}.$$

The diagram of bending moments is sketched in fig. 93. It may be described as the parabolic diagram for a simple beam of span L , erected on a base ab which is the line of pier moments.

Instead of having recourse to the Theorem of Three Moments for finding M we might have proceeded thus:—

$$M_x = M_A + \frac{wx}{2}(L-x).$$

The slope,

$$\begin{aligned} i &= \frac{1}{EI} \int M_x dx \\ &= \frac{1}{EI} \int \left(M_A + \frac{wx}{2}(L-x) \right) dx \\ &= \frac{1}{EI} \left(M_A x + \frac{wLx^2}{4} - \frac{wx^3}{6} \right), \end{aligned}$$

plus a constant of integration which must be zero since the slope is zero when $x=0$.

But $i=0$ when $x=\frac{L}{2}$, and hence

$$M_A \frac{L}{2} + \frac{wL^3}{16} - \frac{wL^3}{48} = 0,$$

from which

$$M_A = \frac{-wL^3}{12}$$

as before.

It is interesting to compare the bending moment borne by the encastred beam with that borne by a beam of the ordinary kind. In a uniformly loaded beam of span L simply resting on end supports the greatest bending moment is $\frac{wL^2}{8}$. The encastred beam is consequently stronger, so far as the maximum moment caused by a uniform load is concerned, in the proportion of 12 to 8, or 3 to 2. It should however be noticed that if any yielding at the supports occurs, which permits the beam to assume a slope at the ends, the advantage of the encastred form is quickly lost.

To find the deflection of the encastred beam, uniformly loaded, we have

$$u = \int i dx = \frac{1}{EI} \int \left(\frac{-wL^3 x}{12} + \frac{wLx^2}{4} - \frac{wx^3}{6} \right) dx.$$

At the middle, where the deflection is greatest, its amount is

$$\frac{wL^4}{384EI}$$

which is only one-fifth of the deflection in a similarly loaded simple beam.

As another example, the case may be mentioned of an encastré beam of uniform section carrying a single load W at the middle. We may proceed as in the former case to find the moment at each support, or more simply infer it from this consideration:—In an indefinitely extended continuous beam of which the given encastré beam represents one span, the pier reactions are each equal to W . The system suffers no change by *inversion*: the bending moment over each pier is therefore equal to the bending moment under each load, and the convex portion of the beam over each pier must be of the same length as the concave portion under each load. Hence the points of inflection are at the distance $\frac{1}{4}L$ from each support. The bending moment at the middle and at each support is $\frac{WL}{8}$ and the diagram of bending moments has the form sketched in fig. 94. The deflection at the middle is readily found by

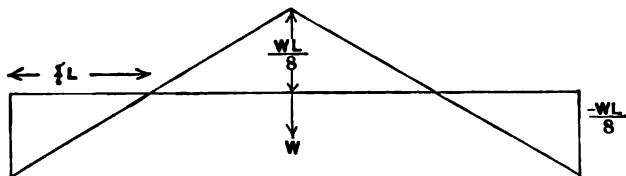

Fig. 94.

adding that of a cantilever of length $\frac{L}{4}$ loaded with $\frac{1}{4}W$ at its end to that of a simple beam of length $\frac{L}{2}$ loaded with $\frac{1}{2}W$ at its middle: its amount is $\frac{WL^3}{192EI}$.

The student will find it interesting to verify these results analytically, and to apply the same method of calculation to the case of a beam encastré at one end and resting at the other on a simple support at the same level.

CHAPTER VIII.

FRAMES.

111. Frames. Among structures capable of bearing bending moments and acting as beams a highly important place is taken by frames. A frame is a structure composed of struts and ties. Although it may be subject to bending as a whole its separate parts or members are simply in tension or compression. This is because the members are attached to one another by joints which cannot transmit a bending moment and because the loads are applied at the joints.

The simplest complete frame is a triangle (fig. 95). If such a frame rests on supports at *A* and *B* and carries a weight at *C* it

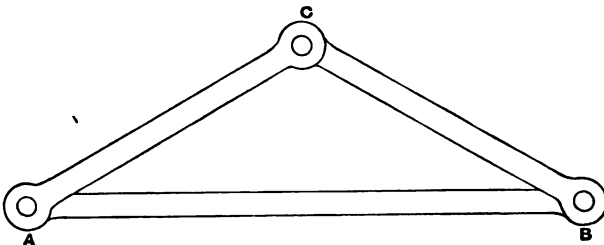

Fig. 95.

is serving as a beam although its three members are individually only subjected to tension and compression. We assume here that the members are connected by joints in which there is perfect freedom of angular movement—a condition which is approximated to when pin and eye joints are used.

112. Perfect, Imperfect, and Redundant Frames. A frame such as that sketched in fig. 96 would be in equilibrium under a particular distribution of loads, but not under any distribution. It is said to be imperfect, because the number of members is insufficient to make the frame preserve its shape when the loads vary. By adding one diagonal member (BC , fig. 97) it is converted into a perfect frame. The configuration now persists however the loads vary. Moreover, under any assigned system of loads the amount of pull and push on each member is determinate.

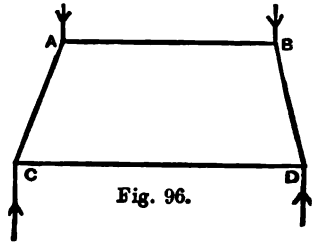

Fig. 96.

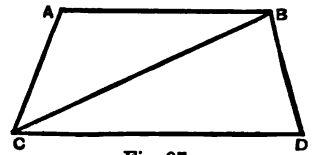

Fig. 97.

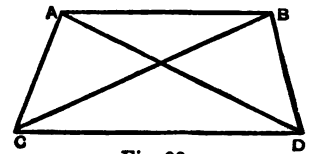

Fig. 98.

Suppose, however, another member were introduced (AD , fig. 98). The amounts of pull and push in the several members are now indeterminate. The frame is now capable of being self-strained: that is, stresses may exist in the members apart from any application of loads. This was not possible in the perfect frame. A frame of this last kind may be described as having one or more redundant members. In practice it is sometimes useful to introduce redundant members for the following reason. Suppose in the frame of fig. 97 there were a great excess of load on joint A . The diagonal member BC would then be acting as a tie. But if the excess of load moved to joint B the diagonal would have to act as a strut. If BC were very flexible, and therefore incapable of acting as a strut, the frame would virtually be imperfect, but it could be made perfect by introducing the other diagonal AD which would then act as a tie. If both diagonals were present from the first, but both capable of acting as ties only, the frame would be well adapted for bearing an excess of load either at A or at B . In each case one of the two diagonals would simply go out of action and the other would serve to complete the frame. Members acting in this way—that is, members capable of serving only as ties, or only as struts, and going out of action when a change in

the distribution of the load tends to reverse the stress in them—are called *semi-members*. We shall have instances of their use later. In general, however, the frames which have to be considered are those with simply the right number of members to be perfect in the sense explained above.

113. Method of Sections. A bridge frame, such as the Warren girder of fig. 99, or the "N" girder or "Linville" truss

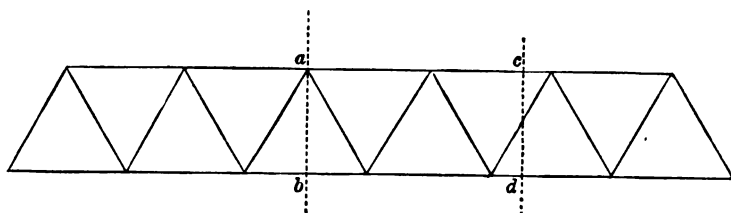

Fig. 99.

of fig. 100, may be regarded as a beam closely analogous to a solid beam of I section, but with this difference that the top and

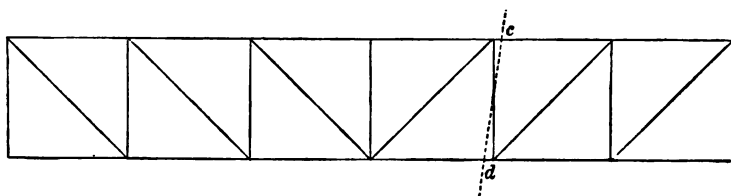

Fig. 100.

bottom lines of members, corresponding to the flanges, are held apart by a network of bracing instead of by a continuous web.

To find the stress in a top or bottom member we may calculate the bending moment M at a vertical section taken through the opposite joint. Take the section ab in Fig. 99. The stress in b prevents the right-hand and left-hand portions of the beam from turning about the joint a as a hinge. Consequently the amount of the stress in b is

$$F_b = \frac{M_{ab}}{h}$$

where h is the depth of the beam at the section, measured from the joint to the middle line of the member b . In applying this method to a beam with vertical members, like that of fig. 100, it

is convenient to think of the section as slightly inclined, so that it escapes coinciding with a vertical member.

This method of sections is also applicable as a means of finding the stresses in what we may call the web members. Let F be the shearing force at any section such as cd , taken so as to cut an inclined member. The top and bottom members which are also cut by that section do nothing towards bearing the shearing force, for the stresses in them are wholly horizontal. Consequently the stress in the inclined member must have such a value that its vertical component is equal to the shearing force F at the section. Hence the stress in the inclined member is

$$\frac{F}{\cos \theta}$$

where θ is the angle the member makes with the vertical.

In applying this principle to a frame with vertical members, the device of taking the section slightly inclined is again useful. Thus by taking cd slightly inclined as in fig. 100 we see at once that the stress in the vertical member it cuts is simply equal to the shearing stress reckoned by adding the loads on all the joints which lie to one or to the other side of the section so taken. To find the stresses in each inclined member of the "N" frame the section is taken vertical as in the Warren girder.

The method of sections is specially convenient when the beam is of uniform depth. To find the stresses then involves little more labour than is required to tabulate the bending moments and shearing forces for successive panels of the frame.

114. Graphic Process. Method of Reciprocal Figures.

As an alternative to the Method of Sections the graphic method of Reciprocal Figures is in all cases practicable, and offers many advantages when the depth of the beam varies. It is the usual method of finding the stresses in the members of roofs, and is applicable to framework generally whatever be the directions of the applied forces.

The method consists in drawing, superposed on one another, the polygons of forces for the several joints of the frame. It will be readily understood by reference to one or two examples.

Take, for instance, the bowstring girder of fig. 101. For the

sake of generality we assume loads which are unequal and un-symmetrical. Find the reaction at each pier, either by taking

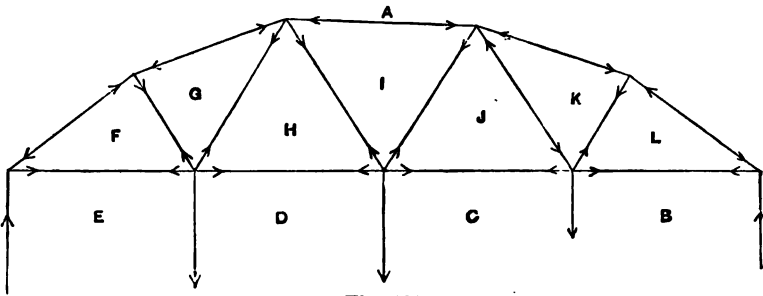

Fig. 101.

moments about the opposite pier or by the graphic process of the funicular polygon described below in § 116. We adopt the method of lettering devised by Henrici and Bow, in which letters are placed in the spaces between members, and in the spaces separated by the lines of action of the applied loads, in a manner which the figure exemplifies. Thus we have the load BC , the pier reaction AB , the members EF , FG , and so on. Similarly the joints are named by the letters round them, thus the girder rests on the left-hand pier at the joint EAF .

Begin by drawing the polygon of forces for that joint (fig. 102). Taking any convenient scale of forces, set out the known force

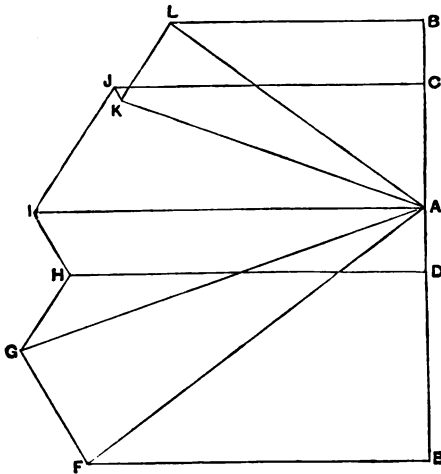

Fig. 102.

EA (fig. 102) and find the forces AF and FE by drawing lines parallel to these lines in the frame. The triangle EAF in fig. 102 is the polygon of forces for the joint EAF in the frame. The forces in the triangle have the directions EA, AF, FE . This shows that the member AF in the frame is a strut, and the member FE is a tie. Mark them so by arrows, and go on to draw the polygon of forces for another joint in the frame. A joint must be taken at which there are not more than two unknown forces: hence the next to be taken is the joint FAG . We use the line FA already drawn in fig. 102, and complete a triangle on it by lines parallel to the members AG and GF . These give the forces in those members. The next joint is $DEFGH$. The forces DE, EF, FG are already known, GH and HD are to be found. Take a point D on the vertical line through E in fig. 102, at a height above E which represents on the scale of forces the load DE : then we have the polygon DE, EF, FG , completed by lines GH, HD parallel to the corresponding members of the frame. By proceeding in the same way from joint to joint the complete diagram of fig. 102 is built up. It is a group of superposed diagrams of forces for the several joints, each line serving twice over, for the stress in each member acts as a force at each of the two joints which the member connects.

The lines in the two figures, the frame and the force diagram, are severally parallel, and each group of lines which meet at a point in the one form a closed polygon in the other. For this reason the figures are described as "reciprocal."

When drawing the force diagram it is important, at each joint, to follow the same order in taking the forces. In the example given above the forces are taken "clockwise" round the joint. At each joint all the known forces are dealt with first, in drawing the polygon, and the polygon is closed by lines parallel to the unknown forces, the number of which must therefore not exceed two.

115. Examples of the Method of Reciprocal Figures.

This graphic method of determining the stresses in the members is applicable to frames of all kinds, loaded in any manner. The externally applied forces need not be vertical. In the diagram of forces they form a closed polygon, since the frame as a whole is in equilibrium under them. When the loads and reactions of the

supports are vertical, the sides of this polygon coalesce into a vertical line: the line of reaction (directed upwards) then coincides

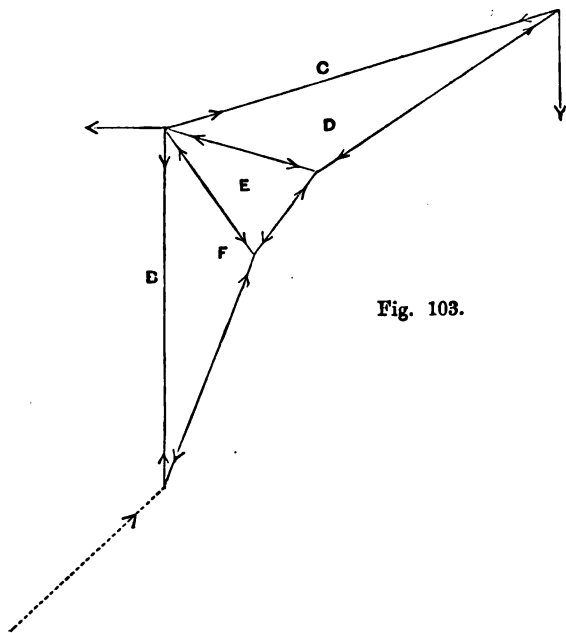

Fig. 103.

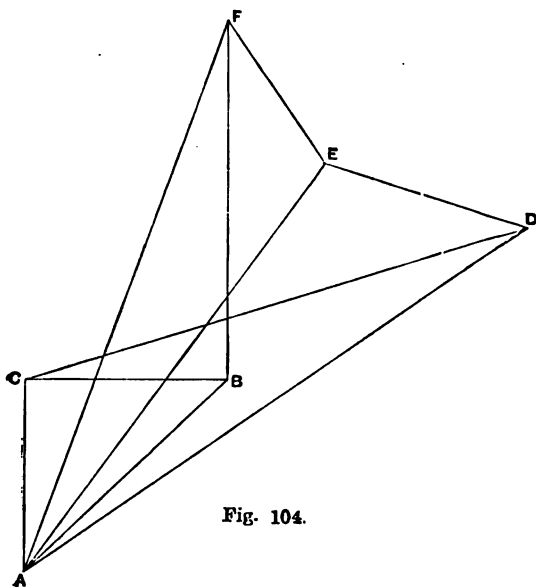

Fig. 104.

with the line of loads (directed downwards). In the diagram, fig. 102, the line of loads is BE ; the reactions are EA and AB .

Figs. 103 and 104 exemplify the method as applied to a crane or bracket supported by a socket at the foot and a horizontal tie CB . The thrust on the socket need not be determined beforehand: it is found when the force diagram is drawn. In drawing the diagram we begin with the joint CAD , then take the joint DAE , and so on. The triangle ABC is the polygon of the external forces, and AB determines the direction and magnitude of the thrust at the socket.

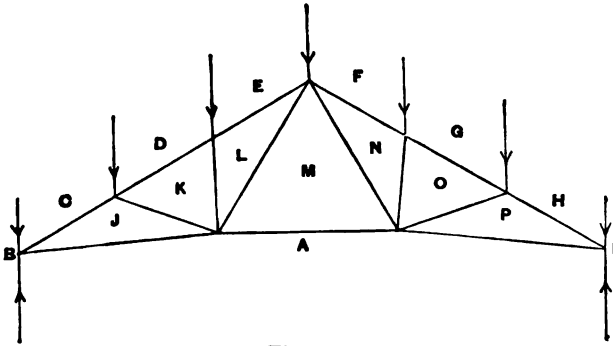

Fig. 105.

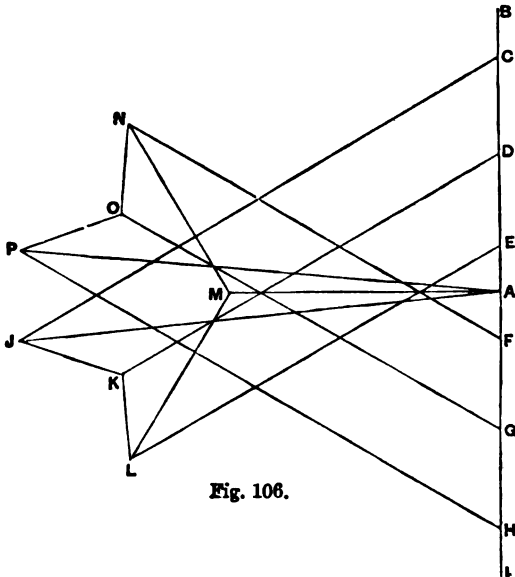

Fig. 106.

Fig. 105 is a simple example of a symmetrically loaded roof. In such a case it suffices to draw half the diagram of forces, but by completing it, as in fig. 106, we have a useful check on the accuracy of the work.

116. Use of the Funicular Polygon in finding the Reactions at the Supports. In fig. 107 the roof frame is

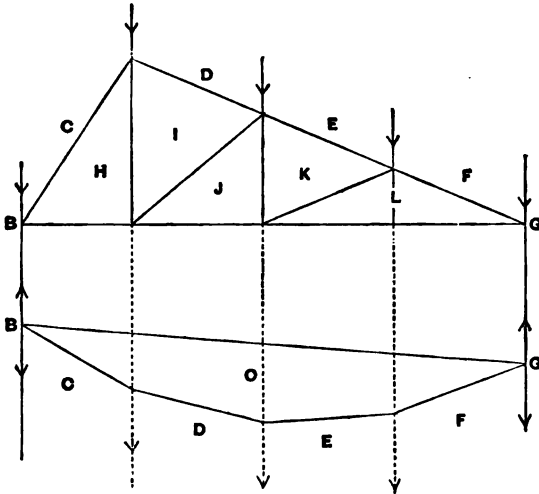

Fig. 107.

unsymmetrical, and this example will serve to show how the reactions at the supports may be graphically determined by the use of the funicular polygon. The funicular polygon is an imaginary chain which would be in equilibrium under the given loads. When the ends of such a chain are held apart by an imaginary bar they produce at the supports which carry them the same reactions as the loaded frame produces. Hence by finding the reactions due to the imaginary loaded chain we find those due to the frame itself.

To draw the funicular polygon, draw the line of loads $BCDEFG$ (fig. 108). Take any pole O and join it with the points B, C, D , etc. Then from any point in the line of the reaction AB draw a line OC (fig. 107), parallel to the line OC of the force diagram, to meet the line CD along which the load CD acts. Complete the funicular polygon by lines OD, OE, OF parallel to the corresponding lines in

the force diagram, and draw the bar OA joining its ends. Then in the force diagram (fig. 108) draw OA parallel to OA in fig. 107.

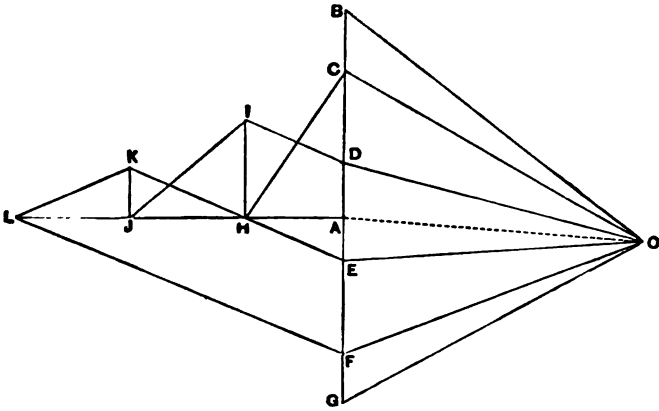

Fig. 108.

It divides the line of loads in a point A such that AB and GA are the reactions which were to be found.

Having determined the reactions, the force diagram for the frame is readily drawn. It is shown on the left-hand side of the line of loads in fig. 108.

In further illustration of the method we may take a case where the loads are not all vertical. "Suppose wind to act on a

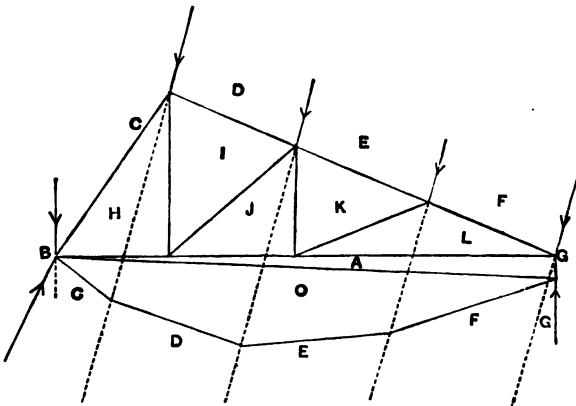

Fig. 109.

frame making the loads CD , DE , EF , and FG inclined as sketched (fig. 109). In that case one or both of the pier reactions must have a horizontal component. Let us assume that the roof is anchored at the left side, but that the reaction GA is vertical. Having drawn the line of loads $BCDEFG$ (fig. 110) and selected a pole O , proceed to draw the funicular polygon, starting from the left-hand side, where the direction of the reaction is not known. This determines the lines OC , OD , OE , OF , OG in fig. 109. The joining bar OA is added, and the line OA is drawn parallel to it in fig. 97, to meet a vertical reaction line from G .

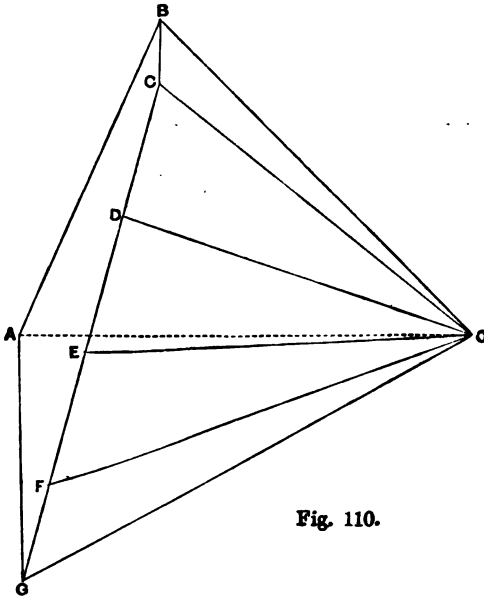

Fig. 110.

This determines GA , which is the reaction at the right-hand end. Then the reaction at the left-hand end is determined in magnitude and direction by the line AB (fig. 110), which completes the polygon $BCGA$ of the external forces. The student will complete for himself the force diagram of the frame.

117. Special Cases. In some frames a difficulty presents itself in the drawing of the reciprocal figure or force diagram, which has to be overcome by a suitable artifice. Consider, for example, the frame of fig. 111. Beginning with the joint $ABCL$ the reciprocal figure is readily drawn for that joint, and for $LCDM$,

and for $ALMN$. But we are then confronted by the difficulty that there are more than two unknown forces at either of the

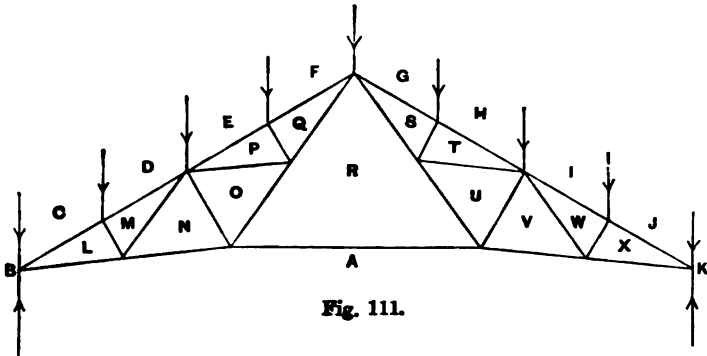

Fig. 111.

neighbouring joints $ANOR$ or $NMDEPO$. In order to proceed with the reciprocal figure, we determine, independently, the stress in AR . This may be conveniently done by the method of sections, taking moments about the top joint, or it may be done graphically by the following device. The stress in AR depends only on the loads and on the skeleton outline of the frame (fig. 112): in other words, it is independent of the character of

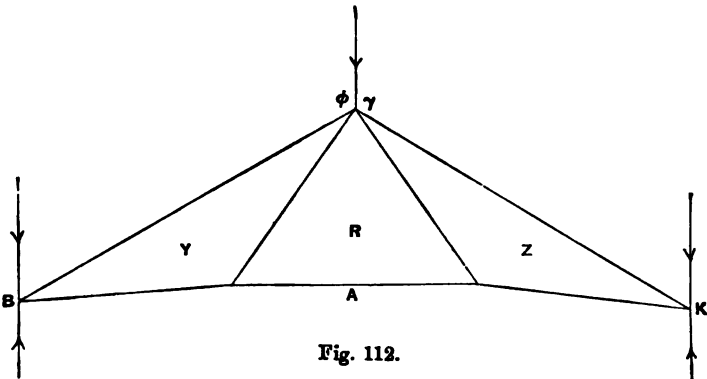

Fig. 112.

the bracing within the panels Y and Z . Hence we may omit this bracing altogether and refer the loads to the top and bottom joints of each rafter as in fig. 99, and then draw as much as is necessary of the reciprocal figure for that simple frame to find the stress in AR . This is done in fig. 113. Another method is to substitute for the actual bracing in the panels Y and Z a form

of bracing which escapes the difficulty, as in fig. 114: then by drawing part of the reciprocal figure for this altered frame we

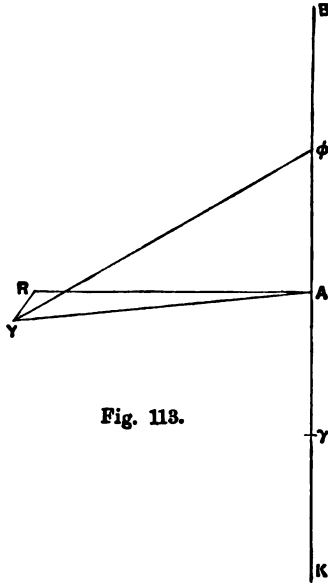

Fig. 113.

find the stress in AR , which is not affected by the change. Having found the stress in AR there is no difficulty in completing

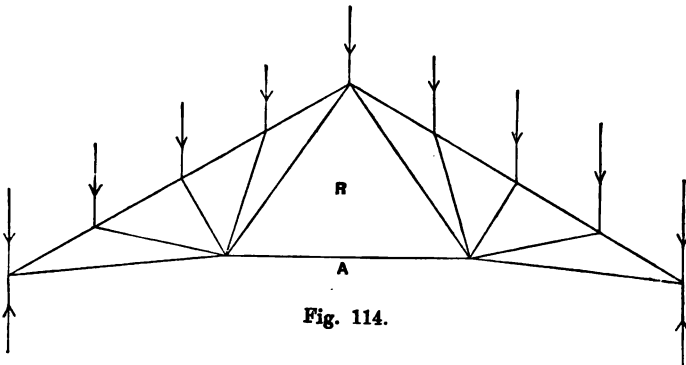

Fig. 114.

the reciprocal figure for the original frame. It is sketched complete in fig. 115.

118. Use of Semi-members in Bridge Frames. Counterbracing. In a frame such as that sketched in fig. 116, the

diagonal members in the panels act as ties if the bridge is symmetrically loaded. To the right of the centre the shearing

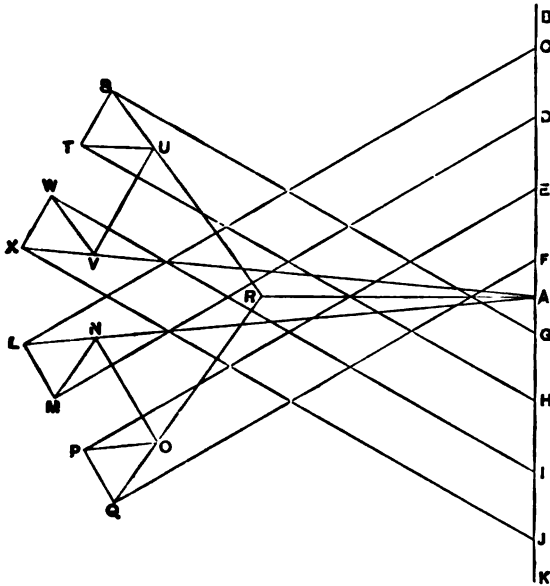

Fig. 115.

stress for any system of symmetrical loads is positive: hence at any section on the right of the centre the diagonal cut by that

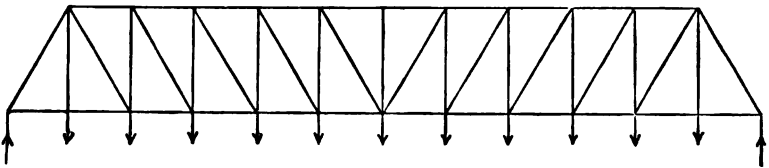
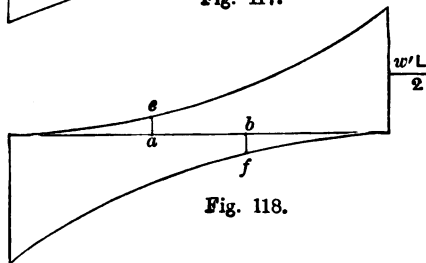
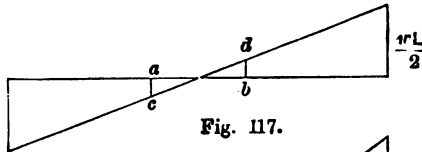

Fig. 116.

section is pulling, to hold down the part of the frame lying to the right of that section. But if the loading is unsymmetrical the shearing force in any panel may change its sign, and in that case the diagonal would have to act as a strut. To avoid this necessity the other diagonal would in general be introduced wherever such a reversal is liable to occur. The two diagonals then form semi-members (§ 112), one being in action only when the loads are such as to make the shearing force positive, and the other only when the shearing force is negative. Panels thus treated are said to be "counterbraced."

In practical cases the load on a bridge consists of two parts; one is the steady load due to the weight of the structure and of the roadway, the other is the variable or rolling load which passes over the bridge. If all the load were of the latter kind the shearing stress would be liable to reversal in every panel during the coming on and passing off of the rolling load, and in that case every panel would have to be counterbraced. But the presence of steady loads tends to prevent this reversal from happening, except in the central panels. Consequently the number of panels which require counterbracing depends on the proportion of the rolling load to the steady load.

In a beam loaded with a steady load w per foot run the diagram of shearing force is that sketched in fig. 117. If a rolling load of w' per foot run be supposed to come on from one end, it causes the shearing stress to take the maximum positive and negative values shown in fig. 118. Under the combined action of both loads the sign of the shearing stress suffers change



throughout the portion ab of the beam, a and b being taken so that $ae = ac$ and $bd = bf$. Outside of the limits ab there is no change in the sign of the shearing stress as the rolling load passes over the beam.

Hence in a frame beam similarly loaded, enough panels would have to be counterbraced to include the region ab . With a frame in which the load is assumed to act at the joints there would be stepped lines in the diagram of shearing force, instead of the continuous lines shown in figs. 117 and 118. The steps follow

the same general outline, and in applying this construction to find the number of panels which should be counterbraced no inconvenience is caused by treating the load as continuous.

Another common instance of the use of semi-members is found in frame piers. The panels of the pier are counterbraced so that one or the other diagonal will be in action when a horizontal load comes from one side or the other, such as would arise from the action of wind on the pier and on the structure which the pier carries.

119. Superposed Frames. Two or more frames may be superposed to form a compound frame, the members of which fulfil distinct functions in each of the component frames. Thus a double Warren or lattice girder (fig. 119) is obtained by superposing the frames of figs. 120 and 121. Each of these is readily examined

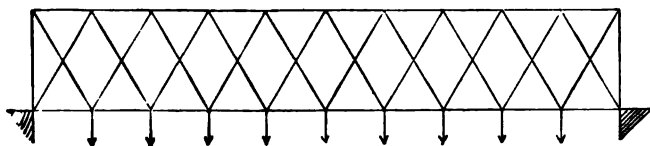

Fig. 119.

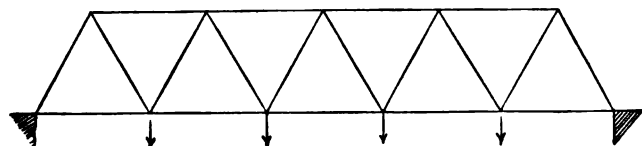

Fig. 120.

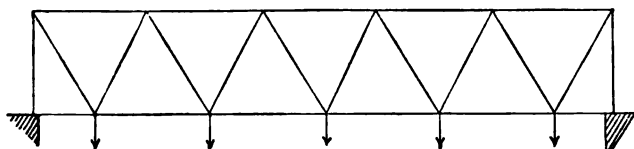

Fig. 121.

by the method of sections or the method of reciprocal figures, and the members which are common to both frames have to bear stresses equal to the sum of those determined for the component frames separately. The Fink truss (fig. 122) and the Bollman

truss (fig. 123) are other examples of compound frames, the only common members in them being those which make up the top boom.

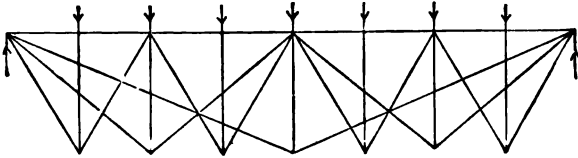

Fig. 122.

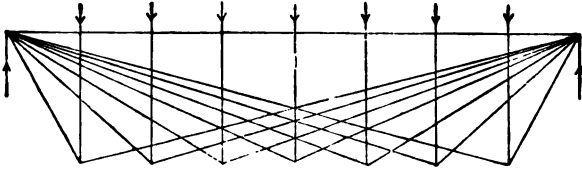

Fig. 123.

120. Effects of Stiff Joints. In the ideal frame the joints are perfectly flexible, in the real frame they are frequently stiff. Where pin and eye joints are used the condition of perfect flexibility is approached—though on account of friction at the pins it is not quite realized. But in many frames no attempt is made to give the members freedom of relative turning at the joints. Rivetted bridge-work and ordinary timber roofs are familiar instances of frames with stiff joints. When the joints are stiff the stresses are, strictly, indeterminate, for the frame may then be self-strained although it has no redundant members. Further, the stresses which are caused by external loads do not then admit of exact determination: the stresses cease to be necessarily axial, and the tension members are liable to be bent as well as pulled. The maximum intensity of stress in the tension bars may therefore be expected to exceed the value which would be found if the joints were flexible. On the other hand the compressed members are, for reasons which will appear in the next chapter, strengthened as well as stiffened by fixing their ends. On the whole the frame with stiff joints will generally be stiffer for small loads than the other: that is, its elastic yielding will at first be less. It may, however, be expected to reach its elastic limit sooner, although if loaded to rupture it may stand a greater load.

CHAPTER IX.

STRUTS AND COLUMNS.

121. Instability under Compression. A piece under compression differs from a piece under tension in this important respect, that if the distribution of the stress is for any reason not strictly uniform, the yielding of the piece tends to increase the inequality instead of reducing it. When a column is compressed, if there is at any stage in the process an inequality in the intensity of stress on two sides, the side that is more strongly stressed yields more than the other, and the column bends in such a manner as to bring the resultant thrust nearer to the more stressed side, with the result that the inequality is made greater than before.

Some initial inequality in the distribution of the stress must in all cases be expected. It may arise from a want of perfect straightness to begin with, or from unsymmetrically shaped ends, or from other causes which make the loading not perfectly axial. Or it may arise from non-uniformity in the elasticity of the column itself, due to a want of homogeneity in the material, or from the casual application of some force distinct from the load.

The influence of this bending is more felt in long columns than in short ones, but it may be traced in the crushing even of a block whose length is four or five times its diameter. Let such a block be tested in compression and it will be found to yield with a smaller total load than would be anticipated from the known crushing strength of the material, and in yielding it will be seen to bend. Experiments intended to determine crushing strength are consequently made in general on blocks which are only about one and a half or two diameters long.

In practical cases a column or strut is usually so long, in comparison with its transverse dimensions, that the tendency to bend under a longitudinal thrust is the main consideration affecting its strength. We accordingly consider first the case of a very long column, the theory relating to very long columns being afterwards modified to make the results applicable to columns of ordinary length.

122. Bending of Long Columns. Euler's Theory.

Consider a strut or column whose length is very great in comparison with its transverse dimensions. Assume it to be originally straight and of uniform section, to be loaded axially, and to be symmetrical as to elasticity. We shall further assume it to have round ends, in other words, that it is free to bend along its whole length, as in fig. 124.

Suppose that while the column carries an end-load it is caused to become slightly deflected (say by the application of a side force which is immediately removed). In consequence of the deflected position of the strut there is now a bending moment acting at every section. If the end-load has a certain value P the deflection will persist: if it has a smaller value the strut will straighten itself; if it has a greater value than P the deflection will increase. We have to find the critical value P which will just serve to keep the strut from straightening itself.

Taking the middle point O of the chord as origin, the bending moment at any section distant y from O is Pu , u being the deflection there. Since the strut is in equilibrium the curvature, $\frac{1}{R}$ or $\frac{d^2u}{dy^2}$, must be proportional at every section to the bending moment, and

$$\frac{d^2u}{dy^2} = -\frac{Pu}{EI},$$

where I is the moment of inertia of the section about a central axis perpendicular to the plane in which curvature has taken place. The negative sign in this equation arises from the fact that the centre of curvature lies on the negative side when the deflection is positive.

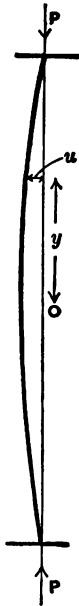

Fig. 124.

Assuming the section of the strut to be uniform, the solution of this equation is

$$u = u_1 \cos y \sqrt{\frac{P}{EI}},$$

where u_1 is the deflection at O^* .

Now $u = 0$ when $y = \frac{L}{2}$, L being the length of the strut, and hence

$$\cos \frac{L}{2} \sqrt{\frac{P}{EI}} = 0,$$

from which $\frac{L}{2} \sqrt{\frac{P}{EI}} = \frac{\pi}{2}$.

Hence the value of P is

$$P = \frac{\pi^2 EI}{L^2}.$$

This is the amount of end-load which is just sufficient to hold the strut bent once curvature has been produced. It is important to notice that P is independent of u_1 : in other words, the same force will serve to keep the strut bent whether the curvature is small or not so small. This is equivalent to saying that the strut is in neutral equilibrium under the critical load P . Under any smaller load it would be in stable equilibrium; under any greater load its equilibrium would be unstable, for the curvature once induced would increase without limit under the action of the load.

Hence this value of P must be taken as the limiting load which the strut can support. In this sense the expression $\frac{\pi^2 EI}{L^2}$ measures the strength of the strut. This is Euler's Theory of the yielding of struts. It is valid only when the strut is long and when the loading is perfectly axial, and the strut is perfectly straight and perfectly symmetrical in respect of elastic quality.

In such a case, the strut on being loaded would show no

* The general solution of the equation is

$$u = A \cos y \sqrt{\frac{P}{EI}} + B \sin y \sqrt{\frac{P}{EI}},$$

where A and B are constants whose values are to be determined from the conditions of the particular case. In the case of fig. 124 the conditions are that $u = u_1$ when $y = 0$, and that $u = 0$ when $y = \frac{L}{2}$, and also when $y = \frac{-L}{2}$.

Hence $B = 0$ and $A = u_1$.

permanent bending (after any casual side force had acted) until the critical load P was reached. Under that load it would maintain any bending that might be given to it. With the least further increase of load it would give way completely.

The condition
$$\cos \frac{L}{2} \sqrt{\frac{P}{EI}} = 0$$

is also satisfied when
$$\frac{L}{2} \sqrt{\frac{P}{EI}} = \frac{n\pi}{2},$$

n being any odd integer. The general solution given in the footnote shows that this applies to even values of n also. This gives a series of higher values of P , namely

$$P = \frac{n^2\pi^2 EI}{L^2}.$$

The physical interpretation of these values is that they are the critical loads for a strut bent in segments, the lengths of which are $\frac{L}{2}$, $\frac{L}{3}$, and so on.

These modes of bending do not however need to be considered in dealing with the strength of struts.

123. Fixed and Free Ends. The above theory requires modification when the ends of the strut are held fixed so that they are forced to remain parallel to the direction of the thrust when the strut bends. This state of things is illustrated in fig. 125. The line of thrust PP then passes through the points of inflection B, D ; by deviating from the ends A, E , it supplies the bending moment required to maintain finite curvature there. The section of the strut being, by assumption, uniform, the condition of equilibrium is identical at points between B and A and at corresponding points between B and C . A corresponding symmetry holds for points above and below D . Hence the points of inflection are at one-fourth of the length from each end. The yielding of the strut takes place under that critical load which would cause yielding in a round-ended strut of the half-length BD —namely when

$$P = \frac{\pi^2 EI}{BD^2} = \frac{4\pi^2 EI}{L^2}.$$

In this case the ends are fixed in such a manner

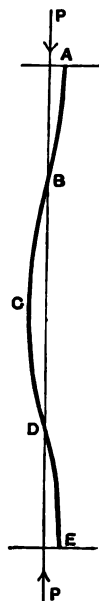

Fig. 125.

that their position as well as direction is maintained. If, however, the conditions were such that there was freedom on the part of the top of the column to move sideways, the direction of the ends only being constrained, then the strut as a whole would be represented by the portion AC of fig. 125, and in that case

$$P = \frac{\pi^2 EI}{L^2},$$

where L stands, as before, for the actual length of the strut.

When one end is fixed and one is free to turn, but not free to move sideways, the bent strut takes a form approximating to the curve BCE of fig. 125, and the critical load is that which would correspond nearly to a round-ended strut of $\frac{3}{4}$ the length, or

$$P = \frac{9\pi^2 EI}{4L^2}.$$

Finally, when one end is fixed, and the other is free not only to turn but to move sideways, the condition of the whole strut is represented by the curve DE of fig. 125, and the critical load is that which would be borne by a round-ended strut whose length is $2L$; in other words

$$P = \frac{\pi^2 EI}{4L^2}.$$

Euler's formula may be expressed to suit all the cases in this form

$$P = \frac{n\pi^2 EI}{L^2},$$

where n is a constant depending on the manner of attachment of the ends.

The cases are summarised below :

	Critical load P by Euler's theory.	n
1. Both ends round.	$\frac{\pi^2 EI}{L^2}$	1
2. Both ends fixed in direction and position.	$\frac{4\pi^2 EI}{L^2}$	4
3. Both ends fixed in direction. One end only fixed in position.	$\frac{\pi^2 EI}{L^2}$	1
4. Both ends fixed in position. One only fixed in direction.	$\frac{9\pi^2 EI}{4L^2}$	$\frac{9}{4}$
5. One end fixed in direction. The other end round and free to move sideways.	$\frac{\pi^2 EI}{4L^2}$	$\frac{1}{4}$

It may be noted in passing that a strut may be attached in such a way that it has round ends with respect to one direction of bending, and fixed ends with respect to the other.

Euler's theory requires important modification when applied in practical cases. It serves however to show the primary importance of giving a strut a form of section in which the moment of inertia is large.

124. Modification of Euler's theory to meet practical conditions. We have next to consider what modifications are imposed on Euler's theory by the conditions which hold in the case of real columns.

In the first place it is clear that a very short column will not yield in the manner contemplated in Euler's theory, but will yield by direct crushing. Its strength will depend, at least mainly, on the crushing strength of the material—a term which does not enter into the Euler formula. For a very short strut the application of that formula would give a load greater than the simple crushing strength of the strut. In the ideal very short strut, where bending plays no part in causing failure, the breaking load would be

$$f_c S,$$

where f_c is the crushing strength of the material and S is the area of section. In the ideal very long strut of Euler's theory the breaking load is

$$\frac{\pi^2 EI}{L^2}.$$

But the breaking load must alter in a continuous manner as we pass from very short to very long lengths, and an equation which will express a continuous relation between the two is to be found.

If we write

$$P = \frac{f_c S}{1 + f_c S \frac{L^2}{\pi^2 EI}},$$

we have a relation between P and L which is continuous and which makes $P = f_c S$ when L is indefinitely small, and also makes $P = \frac{\pi^2 EI}{L^2}$ when L is indefinitely great. In other words,

it makes P approximate to $f_c S$ when the strut is very short, and to $\frac{\pi^2 EI}{L^2}$ when the strut is very long.

Further it gives, for struts of intermediate length, a value of P which is considerably less than the value $\frac{\pi^2 EI}{L^2}$ corresponding to Euler's ideal strut. This is as it should be, for the ideal conditions of perfect straightness, perfect symmetry of elasticity, and perfect centrality in the application of the load are never realised in practice, and any deviation from these conditions makes the actual breaking load less than the ideal load of Euler's formula.

Fig. 126 illustrates the curve which represents the relation of strength to length as expressed by this formula. The height of

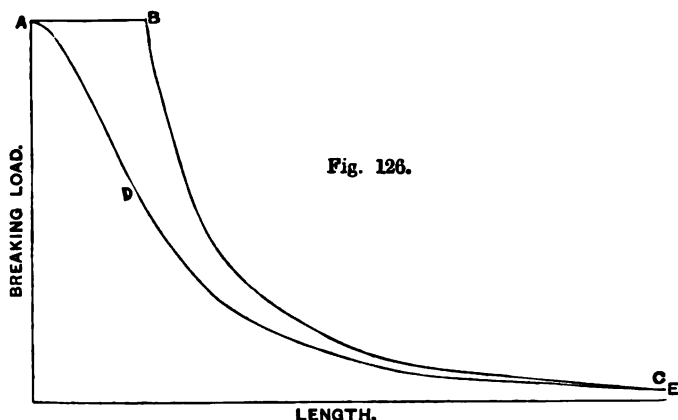

Fig. 126.

A is $f_c S$. The line BC represents values of P found from Euler's equation $P = \frac{\pi^2 EI}{L^2}$. The continuous curve ADE , which rises nearly but not quite as high as BC when the length is very great, is got from the equation stated above.

If now we take the results of any group of experiments made to determine the breaking load of struts of various lengths, of the same material and the same cross-section, we find that the points representing such experiments lie, in general, fairly well on a continuous curve resembling ADE . The experimental curve will however lie lower than the curve BC even when the struts are long, because of the weakening which is introduced by deviation from the ideal conditions assumed in Euler's theory.

Moreover, these sources of weakness are irregular, and cannot be expected to show themselves equally in all the experiments. One strut will be more homogeneous than another, straighter, or more strictly axial in its loading. Hence the results of experiments are found to lie irregularly about such a curve, and it is only at the best a roughly approximate expression of them that can be given by any formula.

The formula may be made to agree most closely with experimental results by treating it as empirical, and adjusting the constants. In other words, the constants in the numerator and denominator are to have such values assigned to them as will make the values of P agree most closely with experiments on struts of the same material but of different lengths.

Thus we may write it in the form

$$P = \frac{fS}{1 + 4c \frac{SL^2}{I}},$$

and then select values of f and $4c$ to suit the available experiments.

This may also be written

$$p = \frac{f}{1 + 4c \frac{L^2}{k^2}},$$

where p is the breaking load expressed per square inch of the section, and k is the radius of gyration of the section with respect to the axis about which bending is most likely to take place, namely the axis about which I is least.

This is for struts with round ends. When the ends are fixed we have

$$p = \frac{f}{1 + c \frac{L^2}{k^2}},$$

and generally we have for the other cases distinguished in § 123, $\frac{4c}{n}$ as the coefficient of $\frac{L^2}{k^2}$, where n has the values stated here.

A formula of this kind was first put forward by Prof. Lewis Gordon, who based it on a suggestion of Tredgold, and it was

adopted with some modification by Rankine. In the form which has just been given it is generally known as Rankine's formula.

In Gordon's original formula, the ratio of length to least breadth of section was used, instead of the ratio of L to k . This alters the constant in the denominator; thus for a strut with fixed ends,

$$p = \frac{f}{1 + a \left(\frac{L}{b}\right)^2},$$

where b is the least breadth of section and a is a constant depending both on the material and on the type of section.

Rankine's modification of Gordon's formula makes it applicable to columns of any section.

The constants a and c are connected by the equation

$$\frac{c}{a} = \frac{k^2}{b^2}.$$

In a strut whose section is a solid rectangle $k^2 = \frac{b^2}{12}$ and consequently $a = 12c$. Other cases are tabulated below.

Form of section	$\frac{k^2}{b^2}$.
Solid rectangle	$\frac{1}{12}$.
Thin hollow square	$\frac{1}{6}$.
Solid circle	$\frac{1}{16}$.
Thin hollow circle	$\frac{1}{8}$.
L, T, or cruciform section with equal sides, each equal to b ,	$\frac{1}{24}$.
H section, with equal web and flanges	$\frac{1}{18}$.

Among the most authoritative experiments from which the values of the constants may be deduced are those of Hodgkinson*. The following table gives some of his results for solid rectangular columns of wrought-iron having flat and well-bedded ends. The

* *Phil. Trans. Roy. Soc.* 1840, 1857.

behaviour of these columns may be taken as that of columns with fixed ends. In all the instances cited here the least width was exactly or approximately 1 inch (generally 1.023 inch), and the other transverse dimension was approximately either 1 or 3 inches. The exact dimensions of the section are used in calculating the breaking load per square inch and the ratio of length L to least breadth b .

Approximate dimensions of section	Length in inches	Ratio $\frac{L}{b}$	Breaking load in tons per square inch. p
1" x 1"	7.5	7.3	21.7
1" x 1"	15	14.6	15.4
1" x 1"	30	29.3	11.3
1" x 3"	30	30	13.2
1" x 1"	60	58.6	7.7
1" x 3"	60	60	8.1
1" x 1"	90	88	4.35
1" x 3"	90	90	4.42
1" x 3"	120	120	1.91

Fig. 127 shows these values of the breaking strength, in

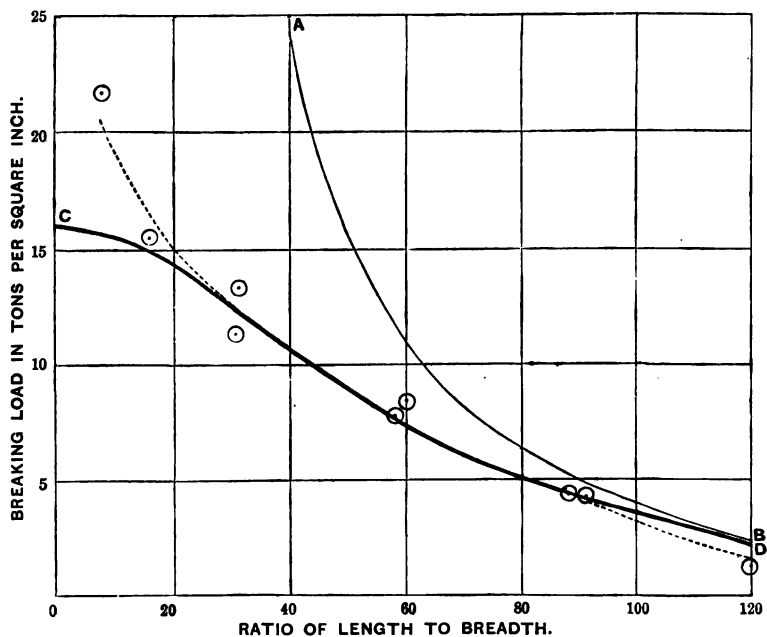

Fig. 127.

relation to the ratio of length to least breadth $\left(\frac{L}{b}\right)$. The separate observations are shown by small circles, and the dotted curve is sketched to lie as well as possible among them. The curve CD , shown by a full line, represents the breaking strength given by Gordon's formula,

$$p = \frac{f}{1 + a\left(\frac{L}{b}\right)^2},$$

where the constants f and a have the values assigned to them which Gordon found to represent best the results of these and other experiments by Hodgkinson on rectangular wrought-iron columns, namely

$$f = 16 \text{ tons per sq. inch,} \quad a = \frac{1}{30000}.$$

The corresponding value of c , the constant in Rankine's formula, would be $\frac{1}{30000}$. These constants are usually accepted for wrought-iron.

Fig. 127 will serve to illustrate the necessarily rough character of experiments or calculations on the strength of columns. The results of experiments differ somewhat widely amongst themselves, and the Gordon or Rankine formula does not express even the average of the experimental results with any great precision. The agreement between the results of experiment and the curve CD of the figure is good for struts whose lengths range from say 20 to 100 times their breadth, but for shorter struts there is considerable discrepancy, of such a kind that the formula errs on the side of safety.

It is interesting to compare these experimental values of the breaking strength with those which would be found, in an ideal strut, on Euler's theory. We may take 12000 tons per square inch as a probable (rather low) value of E in wrought-iron. Then for an ideal column 1 inch square, with fixed ends, Euler's theory would give

$$p = \frac{4\pi^2 EI}{L^2} = \frac{39500}{L^2}$$

in tons per square inch, L being in inches. The curve AB in fig. 127 gives the values of p derived from this. It shows, when compared with the results of the experiments, how wide of the

mark Euler's theory would be if applied to struts of moderate length.

What happens when the real strut is tested under compression is that owing to the departure from the ideal conditions of symmetry in form and quality and load it bends, at first slightly, and each addition of load is associated with a finite increase in the deflection.

In this bent state the distribution of stress is not uniform because the resultant passes away from the centre, and as bending proceeds the stress on the off-side may change to tension. Failure ensues when the greatest compressive stress on one side or the greatest tensile stress on the other exceeds the limit of elasticity.

125. Values of the Constants in other materials. The values of the constants derived from experiments on cast-iron columns with flat ends are

$$f = 36 \text{ tons per sq. inch,} \quad c = 8400.$$

Thus for cast-iron pillar, with flat ends, when the section is a hollow circle, we have

$$p = \frac{36}{1 + \frac{1}{800} \left(\frac{L}{d}\right)^2},$$

where d is the external diameter.

When the section is a solid circle

$$p = \frac{36}{1 + \frac{1}{400} \left(\frac{L}{d}\right)^2}.$$

Experiments on steel columns have been carried out by Mr Christie*, who gives a table of average results. Professor Fidler† finds that these are expressed with a fair degree of accuracy by Rankine's formula, for ratios of $\frac{L}{k}$ greater than 20 and less than 200, taking the following values for the constants:

$$\begin{array}{lll} \text{For mild steel,} & f = 21.4, & c = 30000. \\ \text{For hard steel,} & f = 31.2, & c = 20000. \end{array}$$

* *Trans. American Inst. of Civil Engineers.*

† *Treatise on Bridge Construction.*

It is important to notice that the formulas of Gordon or Rankine with these various empirical constants are not to be accepted as applicable beyond the limits of length reached in the experiments on which the constants are based. If we were to apply them to longer struts they would give a greater strength than is compatible with Euler's theory, whereas a real strut of great length is certainly weaker than Euler's ideal strut. Rankine's formula, for a strut with fixed ends,

$$p = \frac{f}{1 + c \frac{L^2}{k^2}},$$

gives values of p which approximate more and more closely to

$$\frac{f}{c} \cdot \frac{k^2}{L^2}$$

the greater the ratio of L to k becomes.

Now Euler's theory gives for the breaking strength of the long ideal strut

$$\frac{P}{S} = \frac{4\pi^2 EI}{SL^2} = 4\pi^2 E \cdot \frac{k^2}{L^2}.$$

It is certain that the strength of the actual strut is somewhat less, and hence

$$\frac{f}{c} \text{ should be less than } 4\pi^2 E$$

if the practical formula is to be applicable to very long struts. In fact, however, the constants which are usually accepted do not satisfy this test. Thus for wrought-iron or steel $4\pi^2 E$ ranges from about 480000 to 520000, but in wrought-iron

$$\frac{f}{c} \text{ is } 16 \times 36000 = 576000$$

if we take the received values of these constants. For steel the constants stated above make $\frac{f}{c}$ about 620000 or 640000. These considerations only strengthen what has been already said, that a formula expressing the results of experiments on struts is essentially empirical, and has little or no value when extended beyond the limits of experiment.

126. Struts with Lateral Load*. When, in addition to thrust at its ends, a strut carries lateral load which produces bending moment, the strut becomes laterally deflected and the whole bending moment at any section is made up of the bending moment due to the lateral load, together with the bending moment due to the end thrust. Let μ be the bending moment due to lateral load at any section, and u be the deflection there. Then the whole bending moment in that section is

$$M = \mu + Pu,$$

and therefore the curvature

$$\frac{d^2u}{dx^2} = -\frac{1}{EI}(\mu + Pu).$$

To integrate this we must be able to express μ as a function of x , which is the distance from the origin in the direction of the strut's length.

As a particular case, suppose that the lateral load is distributed more or less uniformly. The diagram of bending moment, due to a uniformly distributed load alone, is a parabola which is not very far from coincidence with a curve of sines. Thus if we express the moment due to the lateral load in the form

$$\mu = \frac{1}{8}WL \cos \frac{\pi x}{L}$$

where W is the whole of the distributed load, we get values which are nowhere widely different from the values which would be given by uniform loading. At the middle, where $x=0$, this expression makes $\mu = \frac{1}{8}WL$, and at the ends $\mu=0$. These are correct for uniform loading. At points between the middle and the ends it gives values which are slightly less than those which a uniform loading would produce.

Expressing μ in this manner we have

$$\frac{d^2u}{dx^2} + \frac{Pu}{EI} + \frac{WL}{8EI} \cos \frac{\pi x}{L} = 0,$$

which gives

$$u = \frac{\frac{1}{8}WL \cos \frac{\pi x}{L}}{EI \frac{\pi^2}{L^2} - P},$$

as the equation for the deflection of the strut.

* See a paper by Prof. Perry, *Phil. Mag.*, March, 1892.

At the middle, where this deflection is greatest, its value is

$$u_1 = \frac{WL^3}{8(\pi^2 EI - PL^2)}.$$

The greatest bending moment is

$$\begin{aligned} \mu_1 + Pu_1 &= \frac{WL}{8} + \frac{PWL^3}{8(\pi^2 EI - PL^2)} \\ &= \frac{WL}{8} \left(1 + \frac{P}{\frac{\pi^2 EI}{L^2} - P} \right). \end{aligned}$$

The quantity $\frac{\pi^2 EI}{L^2}$ is the load which would cause instability, by Euler's theory. Calling it Q we may express the greatest bending moment of the laterally loaded strut in the following form:

$$M_1 = \frac{WL}{8} \left(\frac{Q}{Q - P} \right).$$

Having found the greatest bending moment we may readily proceed to find the greatest intensity of stress. It is made up of the stress which the load P alone would cause, if acting axially, together with the stress which is produced by the bending moment. Taking the middle section, where the stress is greatest, let y_1 and y_2 be the distances from a central axis through the centre of gravity of the section to the inner and outer edges respectively. Then the stress due to bending alone produces a compression equal to $\frac{M_1 y_1}{I}$ at the inner edge, and a tension equal to $\frac{M_1 y_2}{I}$ at the outer edge. Hence the greatest intensity of compressive stress, namely at the inner edge of the middle section, is

$$\frac{M_1 y_1}{I} + \frac{P}{A},$$

where A is the area of the section, and I is its moment of inertia about the axis with respect to which bending occurs. The greatest intensity of tensile stress occurs at the outer edge of the middle section, and its value is

$$\frac{M_1 y_2}{I} - \frac{P}{A}.$$

From these expressions that value of P may be calculated which will cause the greatest stress to reach an assigned limit

when the lateral loading is known ; or alternatively the amount of lateral loading can be determined which, in conjunction with a given thrust P , will cause the greatest stress to reach an assigned limit. The theory also serves, of course, to test the suitability of assumed dimensions of section when the end thrust and lateral load are both assigned.

A practical case occurs in the coupling rod of a locomotive which in addition to acting as a strut has to bear a lateral load due to its centrifugal acceleration. Each part of the rod moves in a circle of radius r , making n turns per second. The centrifugal force per unit length of the rod is therefore $\frac{4\pi^2 n^2 r m}{g}$ in pounds weight, where m is the mass of unit length of the rod in lbs.

The bending moment due to centrifugal force is greatest when the rod is at the top or bottom of its path: in each of these positions the effect is that of a lateral load equal to $\frac{4\pi^2 n^2 r m}{g}$ per unit of length. When the rod is exerting longitudinal thrust as well as running at a high speed the thrust and this lateral load should be taken account of jointly. In general however the bending due to centrifugal force is greatest under conditions which exclude longitudinal thrust, namely when the engine is running down hill with steam shut off.

CHAPTER X.

TORSION OF SHAFTS.

127. Torsion of a uniform circular shaft. When a rod or shaft of uniform circular section is twisted, by applying opposite couples to its ends, the axis of the rod being the axis of the couples, the stress is everywhere one of pure shear. The strain may be regarded as due to a rotation of each plane of section relatively to neighbouring planes. At the centre the strain, and therefore the stress, is *nil*, and at other points of the section the amount of the shear is proportional to the distance from the axis. Assuming the strain to lie within the limit of elasticity the intensity of shearing stress q varies with the radius r . A radius DB (fig. 128) turns round to DC , and a straight line AB drawn parallel to the axis at any distance r changes into the helix AC .

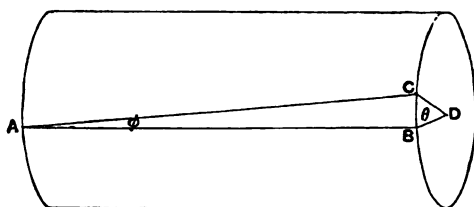

Fig. 128.

Let ϕ be the angle which this helix makes with lines parallel to the axis: then ϕ is what we have called in § 19 the angle of shear, at the distance r from the axis; it is proportional to r . The angle θ or BCD may be called the angle of twist for the length AB ; it is proportional to AB .

Taking two normal cross-sections at a distance δx from one another we have

$$\phi \delta x = r \delta \theta,$$

$$q = C\phi = Cr \frac{\delta \theta}{\delta x},$$

C being the Modulus of Rigidity.

The lines of principal stress are helices inclined at 45° to the direction of the axis.

128. Relation of the greatest intensity of stress to the twisting moment in solid and hollow circular shafts.

Since q varies as r we may write

$$q = \frac{q_1 r}{r_1},$$

where q_1 is the intensity at the surface where it is greatest, and r_1 is the radius of the shaft. The whole moment of the shearing stress distributed over each cross-section must be equal to the moment applied by the twisting couple M . Over any ring of radius r and radial width δr the intensity of stress is q and the total stress is $q \cdot 2\pi r \delta r$. This acts at a radius r , and contributes to the whole moment the quantity

$$q \cdot 2\pi r^2 \delta r.$$

Summing up these quantities for the successive rings into which the whole section may be conceived to be divided, we have

$$M = \int q \cdot 2\pi r^2 dr.$$

Substituting $\frac{q_1 r}{r_1}$ for q this gives

$$M = \frac{2\pi q_1}{r_1} \int r^3 dr.$$

For a solid shaft the limits of integration are from $r = 0$ to $r = r_1$.

Hence for a solid shaft

$$M = \frac{\pi q_1 r_1^3}{2}.$$

For a hollow shaft the internal radius of which is r_2 and the external r_1 ,

$$M = \frac{2\pi q_1}{r_1} \int_{r_2}^{r_1} r^3 dr$$

$$= \frac{\pi q_1 (r_1^4 - r_2^4)}{2r_1}.$$

To express the greatest intensity of stress produced by a given twisting moment M we accordingly have

$$q_1 = \frac{2M}{\pi r_1^3}$$

when the shaft is solid, and

$$q_1 = \frac{2Mr_1}{\pi (r_1^4 - r_2^4)}$$

when it has a central hollow with radius r_2 .

These results may be expressed for both cases by writing

$$q_1 = \frac{Mr_1}{J},$$

where J is the polar moment of inertia of the section, which in a hollow or solid round shaft has twice the value of I the moment of inertia about a diameter.

It is important to notice how little the greatest intensity of stress is increased when a shaft is lightened by removing even a considerable portion of the mass from the centre.

129. Angle of Twist in Round Shafts. Writing i for the angle of twist per unit of length we have

$$i = \frac{\delta\theta}{\delta x} = \frac{\phi}{r} = \frac{q_1}{Cr_1}$$

whether the shaft is hollow or solid. This gives

$$i = \frac{M}{CJ},$$

whence
$$i = \frac{2M}{\pi Cr_1^4} \text{ and } \frac{2M}{\pi C(r_1^4 - r_2^4)}$$

for the two cases. An application of this to the measurement of C has already been given in § 71. Another application is to observe the twist of a shaft as a means of determining the couple, and from that the power, which the shaft is transmitting.

130. Relation of Power transmitted by a Shaft to Torsional Stress and Angle of Twist. In practical problems relating to shafting the data often are the speed of rotation of the shaft, and the number of horse-power it is to transmit. Let H be the horse-power and N the number of revolutions per minute. Then the work done per minute, in inch pounds, is $12 \times 33000H$, and the angle turned through per minute is $2\pi N$. Hence the twisting couple in inch pounds,

$$M = \frac{12 \times 33000H}{2\pi N} = 63030 \frac{H}{N}.$$

Applying this to a solid shaft of diameter d ,

$$q_1 = \frac{2M}{\pi r_1^3} = \frac{16M}{\pi d^3} = \frac{321000H}{Nd^3}.$$

From this
$$d = 68.5 \sqrt[3]{\frac{H}{Nq_1}}.$$

As a safe value of q_1 , 9000 lbs. per square inch is often taken in wrought-iron shafting, which makes

$$d_1 = 3.29 \sqrt[3]{\frac{H}{N}}$$

for wrought-iron.

The greatest stress q_1 may safely be 13500 for steel, and 4500 for cast-iron. The corresponding expressions are

$$d = 2.88 \sqrt[3]{\frac{H}{N}} \text{ for steel;}$$

$$d = 4.15 \sqrt[3]{\frac{H}{N}} \text{ for cast-iron.}$$

It has been assumed here that the twisting moment acting on the shaft is uniform. In many practical cases however the moment varies periodically. A shaft driven by a single crank and connecting rod, for instance, is subject to a moment which varies from a maximum to zero twice in each revolution. The propeller shaft of a steam-ship, driven by two, three, or more cranks suffers smaller, but still considerable, variations in twisting moment. When a fly-wheel intervenes between the source of power and the shaft it tends to smooth out such irregularities, but some irregularity in the moment remains, and in all cases where the

moment is not uniform provision should be made by an appropriate increase in the value of d .

Another reason for increasing d is present in most cases. The shaft is subject to a certain amount of bending as well as twisting. This arises partly from its own weight, partly from the weight of pulleys or spur wheels upon it, and partly from the lateral forces which are brought to bear on it by the gearing or belting through which it takes or gives off power. We shall see presently how to calculate the effect of a bending moment acting in conjunction with a twisting moment when the amount of the bending moment is known. But in many practical cases the bending moments to which the shaft may be liable can scarcely be specified with any certainty, and in such cases the practice is generally followed of increasing the diameter to provide for such contingencies, by an amount which experience of similar shafting has shown to be prudent*.

131. Twisting combined with Bending. When a shaft is subjected to a known bending moment in addition to a known twisting moment we may apply the method exemplified in § 96 to find the magnitude and direction of the greatest principal stress. An important practical instance occurs in the case of a crank-shaft (fig. 129). Let a force P be applied to the crank-pin A at right

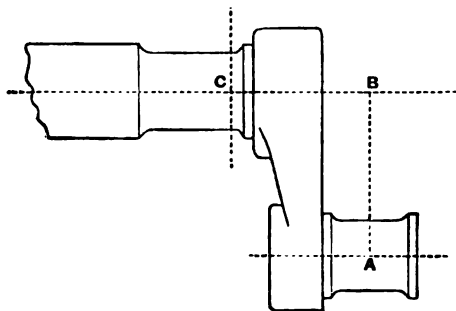

Fig. 129.

angles to the plane ABC . At any section C of the shaft, between the crank and the bearing, the force P gives rise not only to a twisting moment M_1 , the amount of which is $P \cdot AB$, but

* For practical rules on this point reference should be made to Unwin's *Elements of Machine Design*.

also to a bending moment M_2 the amount of which is $P \cdot BC$. There is also a direct shearing force at the section C , the total amount of which is P , but this, as we have seen in § 95, is distributed over the section in such a way that its intensity is zero at the top and bottom of the section. It is at the top and bottom that the intensity of stress due to combined bending and twisting is greatest, and hence in calculating the greatest principal stress we have no direct shearing stress to take account of. At the top and bottom of the section there is, first, a normal longitudinal stress due to bending, the intensity of which is

$$p = \frac{4M_2}{\pi r_1^3},$$

and second, a shearing stress due to torsion, the intensity of which is

$$q = \frac{2M_1}{\pi r_1^3}.$$

When these are combined as in § 96 we obtain for the principal stresses the values

$$\begin{aligned} & \frac{1}{2}p \pm \sqrt{q^2 + \frac{1}{4}p^2} \\ &= \frac{2(M_2 \pm \sqrt{M_1^2 + M_2^2})}{\pi r_1^3}. \end{aligned}$$

Hence the greater principal stress has the same value as the stress which would be produced by the application of a bending moment of the magnitude

$$\frac{1}{2}(M_2 + \sqrt{M_1^2 + M_2^2}),$$

without any twisting. This is sometimes called the equivalent bending moment. In the same way the quantity

$$M_2 + \sqrt{M_1^2 + M_2^2}$$

is sometimes called the equivalent twisting moment, as being the moment which if acting alone to produce torsion would produce a stress numerically equal to the greatest stress which the actual combination of bending and twisting moments produces. The student should, however, be careful to notice that the greatest stress produced by the combination is a normal stress, whereas that due to a twisting moment is a shearing stress, and for this reason the conception of an equivalent bending moment is less open to criticism than that of an equivalent twisting moment.

Since $M_1 = P \cdot AB$ and $M_2 = P \cdot BC$, the equivalent bending moment may be expressed as

$$\frac{1}{2}P(BC + \sqrt{AB^2 + BC^2})$$

or

$$\frac{1}{2}P(BC + AC).$$

The greatest shearing stress, due to the combined bending and twisting, being by § 96, $\sqrt{q^2 + \frac{1}{2}p^2}$, is equal to

$$\frac{2\sqrt{M_1^2 + M_2^2}}{\pi r_1^3} = \frac{2P \cdot AC}{\pi r_1^3}.$$

The axes of principal stress are inclined so that

$$\tan 2\theta = \frac{M_1}{M_2} = \frac{AB}{BC},$$

θ being their inclination to the section.

In all cases of combined twisting and bending, whether the moments are due to forces applied to a crank or to other causes, the method here given may be applied to find the equivalent bending moment, or to calculate directly the principal stresses and the greatest shearing stress. The joint effect of the two moments is readily exhibited by drawing a diagram showing the equivalent bending moment at all sections of the shaft*.

132. Resilience of a Round Shaft under torsion. The work done in twisting unit length of a shaft, within the limit of elasticity, is

$$\frac{1}{2}Mi$$

where M is the twisting moment and i is the angle of twist per unit of length. We have seen (§ 129) that

$$i = \frac{q_1}{Cr_1}$$

and

$$M = \frac{\pi r_1^3 q_1}{2}.$$

Hence the work done per unit of length is

$$\frac{q_1^2 \pi r_1^3}{4C}$$

* For examples see Unwin's *Elements of Machine Design*.

and hence the mean resilience, per unit of volume of the material, is

$$\frac{q_1^2}{4C},$$

an expression which may be compared with those already given for a rod under pull, and for a bent bar.

If instead of a solid shaft we are dealing with a hollow shaft whose thickness is small compared with its radius, the resilience per unit of volume approximates to the value

$$\frac{q_1^2}{2C},$$

all the material being then subject to a stress which approximates to q_1 .

133. Torsion beyond the Elastic Limit. When the twisting of a round shaft is carried beyond the elastic limit the first portion to take permanent set is a ring round the circumference, and if the material is reasonably plastic the stress on this ring ceases to increase or increases only very slightly when an increased twisting couple is applied. With increased torsion more and more rings become similarly affected, and the condition of the shaft ultimately approximates to one in which the shearing stress is uniform throughout the section. Thus if q' be the ultimate shearing strength of the material, the twisting moment which is required to break the shaft approximates to the value

$$M = \int q' 2\pi r^2 dr = \frac{2\pi q' r^3}{3},$$

for a solid shaft, or

$$\frac{2\pi q' (r_1^3 - r_2^3)}{3}$$

for a hollow shaft.

The moment, in the case of a solid shaft, has therefore a value greater in the ratio of 4 to 3 than that which it would have if a uniformly varying distribution of stress were maintained.

The ultimate strength of a shaft to resist torsion is not to be inferred from a knowledge of the shearing strength of the material any more than the ultimate strength of a beam to resist bending is to be inferred from a knowledge of the tensile strength and crushing strength of the material, and experiments on rupture by

torsion are not a satisfactory way of obtaining data with respect to shearing strength.

134. Spiral Springs. An ordinary helical or "spiral" spring yields mainly by torsion. There is in strictness some bending as well, but when the slope of the helix is very small the bending is insignificant, and the strain may be treated as approximating closely to pure torsion. This is the case when the spring is closely wound and the diameter of the helix is large compared with the diameter of the wire or rod of which the spring is made.

Let a be the radius of the helix and r the radius of the wire, which we assume to be circular in section. A load P , stretching the spring, exerts a twisting moment Pa on the wire. It produces a shearing stress, due to this torsion, the greatest value of which is

$$q_1 = \frac{2Pa}{\pi r^2}.$$

The angle of twist per unit of length is

$$i = \frac{q_1}{Cr} = \frac{2Pa}{\pi Cr^3} = \frac{Pa}{CJ}.$$

The whole angle of twist is il , when l is the length of the wire composing the helix. It is this twist that causes one end of the spring to move out when the other end is held fixed.

Every element in the length of the wire produces by its twist a displacement of the point from which the load is hung, through a distance equal to the product of the angle of twist into the radius of the coil. Hence the whole amount by which the spring is extended is

$$ail = \frac{2Pa^2l}{\pi Cr^3}.$$

The work done in stretching the spring is half the product of this quantity into P , an expression which is easily shown to be equivalent to $\frac{q_1^2}{4C}$ per unit of volume of the wire.

A numerical comparison of the resilience of a spiral spring with that of a bent rod will show that a considerably larger amount of energy can be stored in a spring where the strain is torsional than in one where the material is strained by bending.

The best disposition of all, that is to say the disposition which would allow a given weight of material to store the greatest amount of energy, would be that of a thin hollow tube of circular section, strained in torsion. A spiral spring made of such a tube would store an amount of energy approximating to $\frac{q^2}{2C}$ per unit of volume.

We have already seen that a rod directly extended has a resilience equal to $\frac{p^2}{2E}$, and a bent rod (if rectangular in section) when subjected to a uniform bending moment has a resilience equal to $\frac{p^2}{6E}$. Since E is generally about $\frac{1}{2}C$, these quantities are less than the resilience of the twisted tube in the ratio of $2\frac{1}{2}$ and $7\frac{1}{2}$ respectively, if we assume that equal intensities of normal stress and shearing stress are permissible.

135. Helix in which the obliquity is considerable.

The spiral spring dealt with in the preceding paragraph was supposed to have coils so flat that the strain could be treated as simply one of torsion. When the obliquity of the coils is considerable, the effect of bending has to be taken account of. Let α be the inclination of the wire to a plane perpendicular to the axis of the helix (fig. 130). Then the moment due to the

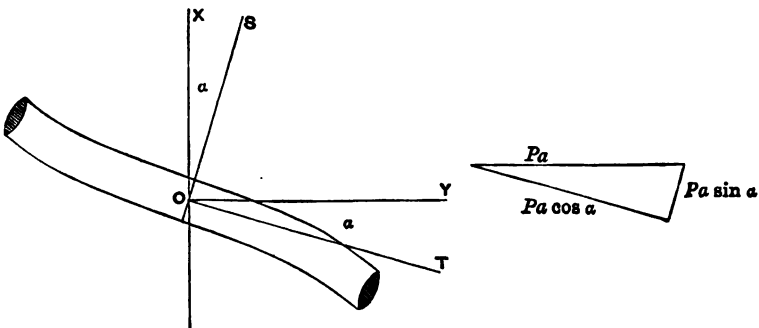

Fig. 130.

load, namely Pa , which acts about the axis OY may be resolved into two moments,

$$Pa \cos \alpha \text{ and } Pa \sin \alpha,$$

acting about OT and OS respectively, of which $Pa \cos \alpha$ produces twisting about the axis of the wire OT , and $Pa \sin \alpha$ produces bending about the axis OS perpendicular to the axis of the wire.

Hence the angle of twist per unit of length is

$$\frac{Pa \cos \alpha}{CJ},$$

and the angle of bending per unit of length is

$$\frac{Pa \sin \alpha}{EI}.$$

Now resolve each of these angles about the axes OX and OY to find the horizontal and vertical components of the angular displacement, per unit of length of the wire. Call the horizontal and vertical components of angular displacement $\frac{\theta}{l}$ and $\frac{\phi}{l}$ respectively, l being the length of the wire. The horizontal angular displacement is reckoned as positive when it implies increase of curvature in the helix.

The horizontal component of angular displacement, about OX , due to the twist is $\frac{Pa \cos \alpha}{CJ} \cdot \sin \alpha$ and is positive. The horizontal component of angular displacement due to the bending is negative and its value is $-\frac{Pa \sin \alpha}{EI} \cdot \cos \alpha$.

Hence

$$\frac{\theta}{l} = Pa \sin \alpha \cos \alpha \left(\frac{1}{CJ} - \frac{1}{EI} \right).$$

Both bending and twisting produce positive vertical components of angular displacement, and the amount due to the two is

$$\frac{\phi}{l} = Pa \left(\frac{\cos^2 \alpha}{CJ} + \frac{\sin^2 \alpha}{EI} \right).$$

We are of course assuming here that the strains are small and that the principle of superposition is applicable.

Hence the axial extension of the spring, which is $a\phi$, is

$$e = Pa^2 l \left(\frac{\cos^2 \alpha}{CJ} + \frac{\sin^2 \alpha}{EI} \right),$$

and the whole angular displacement of the free end in the horizontal direction is

$$\theta = Pal \sin \alpha \cos \alpha \left(\frac{1}{CJ} - \frac{1}{EI} \right).$$

In a wire of circular section $J = 2I$, and C is in general about $\frac{3}{2}E$. Hence the quantity

$$\frac{1}{CJ} - \frac{1}{EI}$$

is in that case positive and its value is about $\frac{1}{4EI}$. The positive sign means that such a spring coils itself closer as it stretches*. When α is infinitesimally small θ vanishes, and the expression for the axial extension becomes $\frac{Pa^2l}{CJ}$ as before.

The expressions given here for e and θ are not applicable to springs in which the section of the wire is other than round, for, as will be shown in the next paragraph, the torsional rigidity of other sections is not correctly expressed by CJ . It is, however, in general not excessively different from CJ , and hence it will be obvious that if a section be chosen in which J is very much greater than I the value of θ may come to be negative: in other words, a spring may be made which will unwind when it is stretched. Let the spring for instance be wound from a thin strip, so that the section has a depth much greater than its width measured radially to the coil. Then I is small and J is relatively very large. Although the expression given above for θ is not applicable to such a section without modification, it serves to show that θ may be expected to be negative in such a case, and to have a comparatively large value. With such a spring there is, in fact, a large rotation of the free end. Since this rotation is proportional to the applied load it may be used, instead of the extension, as a means of measuring the load. This property of springs wound from flat strips has been discussed by Professors Ayrton and Perry†, who have also applied such springs to a number of uses in the design of instruments.

* The treatment of spiral springs is easily extended to include cases in which a known couple is acting horizontally, to wind up the spring, in addition to, or in place of, an axial load, and also cases in which horizontal angular displacement is prevented from taking place. See Perry's *Applied Mechanics*, Chapter XXVIII.

† *Proc. Roy. Soc.* No. 230, 1884.

136. Torsion of non-circular shafts. It is only in shafts of circular section that the shearing stress is uniform at all points equally distant from the axis, and varies uniformly along the radius. If the shaft has any other form, the stress due to a torsional couple is distributed over the section in a much less simple manner.

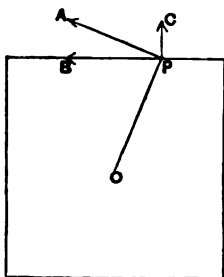

Fig. 131.

To see that this is the case, consider the stress at any point on the surface of a shaft in which the edge of the section is not perpendicular to the radius. A shearing stress at P perpendicular to the radius there, namely PA , may be resolved into shearing stresses PB along the edge of the section and PC perpendicular to the edge of the section. Each of these must be associated with equal shearing stress in a plane parallel to the axis of the shaft. Thus PC must be associated with a shearing stress parallel to the axis on a plane tangent to the surface of the shaft at P . But such a stress cannot exist unless forces parallel to the length of the shaft are applied at the boundary. In other words, a simple twisting couple cannot by itself produce in a non-circular shaft a distribution of stress such that the direction of shear is everywhere perpendicular to the radius. To produce such a distribution would require the application of longitudinal forces to the boundary, in addition to the twisting couple.

It follows that we cannot apply the formula $\frac{M}{CJ}$ to reckon the angle of twist in a square or, generally, a non-circular section, nor treat the intensity of stress as $\frac{Mr}{J}$, as it was in a hollow or solid shaft of circular section.

The actual distribution of stress produced by simple twist in

shafts of square, triangular and other forms of section has been investigated by St Venant, who has shown that in a shaft of square section the greatest intensity of stress occurs at the middle of each side, and that its value then is $\frac{M}{0.208h^3}$, h being the side of the square. This intensity is greater, by about one-seventh, than the greatest value which would have been found if the formula $\frac{Mr}{J}$ were applicable. Again, St Venant shows that the torsional rigidity of a square shaft is $0.84CJ$ instead of CJ ; in other words, that the angle of twist of a square shaft per unit of length, due to a twisting couple M , is

$$\frac{M}{0.84CJ}.$$

The torsional rigidity of a square shaft is consequently less than that of a solid round shaft of the same sectional area in the ratio of 0.88 to 1.

When the section is an equilateral triangle St Venant finds the torsional rigidity is $0.6CJ$, which is 0.73 times that of a circular shaft of equal section.

137. Stability of Shafts under End Thrust and Torsion. Professor Greenhill has investigated the influence which torsion produces on the stability of a shaft exposed to end thrust*. Taking end thrust alone the theory of Euler leads, as we have seen, to the conclusion that instability is produced by a thrust P when it is so related to the effective length L that

$$\frac{\pi^2}{L^2} = \frac{P}{EI}.$$

Professor Greenhill finds that when there is a torsional couple T acting on a round shaft in addition to end thrust, the condition producing instability is that

$$\frac{\pi^2}{L^2} = \frac{P}{EI} + \frac{T^2}{4E^2I^2}.$$

The second term is so small, in practical cases, that it need not in general be taken account of in estimating the stability.

* *Proc. Inst. Mechl. Eng.*, 1883.

The instability which may be produced in a shaft by the action of an end thrust is quite distinct from the instability described in the next paragraph.

138. Centrifugal whirling of shafts. This action, although it has nothing to do with the torsion of shafts, may usefully be described when we are dealing with the causes of instability to which a shaft is liable.

When a shaft revolves at a high speed its own inertia gives it a tendency to instability which is distinct from, although analogous to, the instability of a long column under end thrust. This instability is independent of any torsion to which the shaft may be subjected. It results from centrifugal force coming into play as soon as the shaft deviates from perfect straightness. At a particular speed the centrifugal force is just sufficient to keep the shaft bent and the state of things is then analogous to that of a column sustaining an end load equal to Euler's limiting value. The effect on the shaft is that when this critical speed is reached the amount *pari passu* with the deflection, and the shaft is then said to "whirl."

Let w be the mass of the shaft per unit of length, and n the number of revolutions per second. Then the centrifugal force at any place where the deflection from straightness is u is

$$\frac{4\pi^2 n^2 w u}{g}$$

per unit of length of the shaft. This is equivalent to a lateral load causing bending, and the bending moment M caused by it must be such that

$$\frac{d^2 M}{dx^2} = \frac{4\pi^2 n^2 w u}{g}.$$

The curvature of the shaft due to this bending moment is

$$\frac{d^2 u}{dx^2} = \frac{M}{EI}$$

where I is the moment of inertia of the section about a diameter.

Hence

$$\frac{d^4 u}{dx^4} = \frac{4\pi^2 n^2 w u}{gEI},$$

which for brevity we shall write

$$\frac{d^4u}{dx^4} = m^4u,$$

using m to represent $\left(\frac{4\pi^2n^2w}{gEI}\right)^{\frac{1}{2}}$.

The general solution of this equation is

$$u = A \cosh mx + B \sinh mx + C \cos mx + D \sin mx.$$

When the shaft is simply supported at bearings but not held in them in such a manner as to fix its direction there, it is free to bend along the whole length L between the bearings. In that case the deflection and the bending moment are zero at each end. Hence, taking the origin at the middle, $u=0$ and $\frac{d^2u}{dx^2}=0$ when $x=\frac{L}{2}$ and when $x=-\frac{L}{2}$. Further $\frac{du}{dx}=0$ when $x=0$.

From these conditions it follows that A, B and D each = 0, and the equation for the deflection becomes

$$u = C \cos mx,$$

where C is the deflection at the middle.

Then since $u=0$ when $x=\frac{L}{2}$

$$\cos \frac{mL}{2} = 0,$$

from which

$$\frac{mL}{2} = \frac{\pi}{2}.$$

Hence the length L between bearings and the speed n which causes whirling are related to one another thus :

$$L = \frac{\pi}{m} = \pi \left(\frac{gEI}{4\pi^2n^2w}\right)^{\frac{1}{2}} = \left(\frac{\pi^3gEI}{4n^2w}\right)^{\frac{1}{2}},$$

or

$$n = \frac{\pi}{2L^2} \sqrt{\frac{gEI}{w}}.$$

When the bearings are such as to fix the direction of the shaft at each end it may be shown that

$$mL = 4.74.$$

Other interesting cases arise when the shaft carries one or more pulleys, the mass of which has the effect of increasing the tendency

to whirl. The student is referred to a paper by Professor Dunkerley (*Phil. Trans. Roy. Soc.* 1894) where a large number of cases are considered in detail, and where an account will be found of experiments by which the results of the theoretical investigation were put to the test.

The formula which expresses the condition giving rise to whirling in an unloaded shaft supported by bearings which do not fix the directions of its ends, namely

$$n = \frac{\pi}{2L^3} \sqrt{\frac{gEI}{w}},$$

may be put into a form more convenient for application to ordinary shafting. For iron or steel we may take E to be about 30,000,000 lbs. per square inch, and the weight to be 0.28 lbs. per cubic inch. Hence for an iron or steel shaft the formula becomes

$$n = \frac{\pi}{2L^3} \sqrt{\frac{32.2 \times 12 \times 30,000,000}{0.28\pi r^2}} \cdot \frac{\pi r^4}{4},$$

where r is the radius of the shaft and L is the length between the bearings, both in inches. This gives

$$n = \frac{160,000r}{L^3},$$

or
$$L = 400 \sqrt{\frac{r}{n}},$$

n being the number of revolutions per second as before.

CHAPTER XI.

SHELLS AND THICK CYLINDERS.

139. Stress in a Thin Shell due to Internal Pressure.

When a circular cylinder contains a fluid under pressure the material of the cylinder is thrown into a state of circumferential tension, which may be treated as sensibly uniform if the thickness of the wall is small in comparison with the diameter of the cylinder. Such a thin cylinder is called for brevity a shell, and the circumferential stress is called the hoop tension. The barrel of a cylindrical boiler is in effect such a shell: the thickness of the plates being so small relatively to the diameter that we may without sensible error consider the hoop tension to be uniform throughout the thickness of a plate.

To find the relation of the hoop tension f to the radial pressure p , consider the equilibrium of a piece of a shell subtending a small angle θ at the axis of the cylinder. The piece which is shown in elevation and plan in fig. 132 has four sides, two of which (AC and BD) are parallel to the axis of the cylinder, and the other two are perpendicular to these. As the piece is supposed to form part of a uniform circular cylinder there can be no shearing stress on any of the four sides, for the neighbouring pieces are under identical conditions, and further, whatever normal force acts on AB must be balanced by an equal and opposite normal force on CD . The only forces left to be considered are the hoop tensions on AC and BD , indicated by arrows in the figure, and the pressure of the fluid on the inner surface of the piece.

The piece is in equilibrium under the action of the three forces P , T , and T , where P is the outward push which the fluid

exerts on it, and T, T are the pulls exerted on its sides AC and BD by neighbouring pieces, in consequence of the hoop tension.

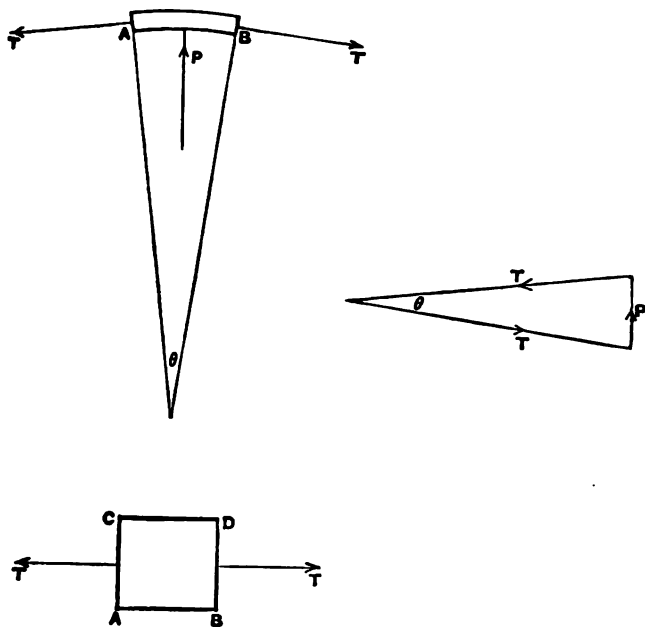

Fig. 132.

Let the width of the piece measured parallel to the axis, namely AC or BD , be unity. The circumferential length AB is $r\theta$. Then, since θ is small, P is sensibly equal to the product of the intensity of the fluid pressure into the area of the piece,

$$P = pr\theta,$$

and

$$T = ft,$$

t being the thickness of the shell.

But

$$P = T\theta$$

by the triangle of forces (fig. 132).

Hence

$$ft = pr,$$

$$f = \frac{pr}{t}.$$

This result is evidently applicable to a thin shell exposed to external as well as internal pressure, if P be taken to represent the excess of the internal pressure over the external.

The same result can be arrived at almost more simply by considering the equilibrium of half the cylinder. Here P , the

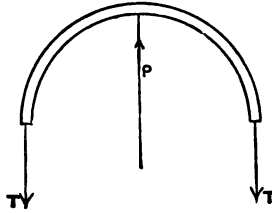

Fig. 133.

resultant of the internal pressure, is $2prl$ where l is the length of the piece under consideration. This piece is balanced by $T + T$. Hence

$$2T = 2prl,$$

$$2fl = 2prl,$$

$$f = \frac{pr}{t}$$

as before.

140. Longitudinal Stress in Cylinder exposed to Internal Pressure. If the ends of the cylinder are held together by longitudinal stress on the cylinder itself, and not by separate stays or other supports, there will be a longitudinal stress, the amount of which is readily found by imagining a transverse division AB , fig. 134, and considering the equilibrium of either of the

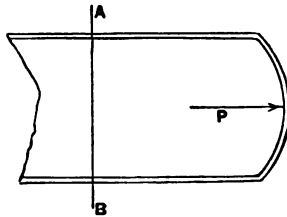

Fig. 134.

two portions, say the portion to the right. The sketch shows the cylinder, with its end, in section. Whatever the form of the end be, the resultant of the internal pressure on it is a force P acting along the axis of the cylinder and equal to pS where S is the area of section of the shell, as a whole, namely the area πr^2 . This force

is balanced by a longitudinal stress f' acting over the ring which constitutes the section at AB , namely the ring whose area is $2\pi rt$. Hence

$$f' \cdot 2\pi rt = p \cdot \pi r^2,$$

$$f' = \frac{pr}{2t}.$$

Thus the longitudinal tension f' is half the hoop tension f .

It is clear that if the ends are held together by stays, or in any manner other than by the material of the shell itself, the relation stated here does not exist. It is easy to imagine cases in which the presence of stays prevents any longitudinal tension from coming on the shell, and even cases in which an excess of tightness in the stays may put the shell into a state of longitudinal compression.

141. Spherical Shell. The tensile stress in a thin spherical shell is at once found by imagining a diametral plane of division, and considering the equilibrium of each half. The resultant fluid pressure is $p \cdot \pi r^2$: the resultant of the tensile stress on the ring section is $f \cdot 2\pi rt$. Hence

$$f = \frac{pr}{2t}.$$

142. Cylindrical Shell of oval section. In a cylindrical shell of oval section, fig. 135, such as the tube of a Bourdon pressure-gauge, the equilibrium of the halves separated by a plane AB shows that if f is the hoop tension at A or at B ,

$$2f \cdot t = p \cdot \overline{AB},$$

$$f = \frac{p \cdot \overline{AB}}{2t}.$$

Similarly, if f' is the hoop tension at A' or B' ,

$$f' = \frac{p \cdot \overline{A'B'}}{2t}.$$

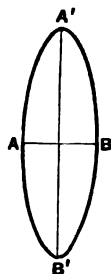

Fig. 135.

Thus the greater hoop tension is found at the places of greater curvature. A piece of the shell at A or at B is supported against the pressure within, not merely by the hoop tension which results from the curvature there, but also by shearing stress on the sides of the piece which face towards A' and B' . This shearing stress

is associated with a bending moment which acts upon any annular strip of the tube bounded by two parallel transverse sections. The bending moment varies, from point to point round the strip, both in amount and in sign, in such a way that its tendency is everywhere to make the section more nearly circular.

143. Thick Circular Cylinder. We have next to consider the distribution of hoop tension in a circular cylinder so thick that the hoop tension cannot be treated as having the same intensity from inside to outside.

We may regard the whole thickness as made up of a series of superposed rings. The radial pressure is transmitted from ring to

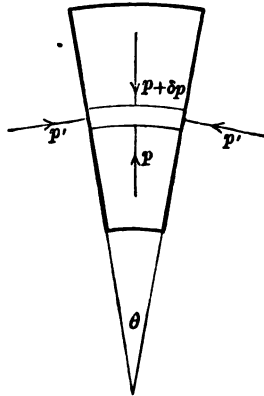

Fig. 136.

ring with reduced intensity, and the hoop tension decreases as we pass out from one ring to the next. Consider a small piece of a ring, anywhere within the thickness. Let r be its inner radius and $r + \delta r$ its outer radius. On the inner surface of such a ring there is a certain intensity of radial pressure p . We may write $p + \delta p$ as the intensity of radial pressure on the outer surface, it being understood that δp will be negative in the usual case, namely when a cylinder has to bear an excess of internal pressure.

The radial pressure p is one of the three principal stresses. Another is the hoop stress p' , and the third is the longitudinal stress, parallel to the axis, which does not need to be taken account of in considering the equilibrium of the piece, since it has equal and opposite values on the front and back faces.

Reckoning push stresses as positive, we shall find that p' has a negative value when there is an excess of pressure within the cylinder.

As before we take the width of the piece to be unity in the direction of the length of the cylinder, and assume θ to be small.

Then the whole radial force acting on the piece (reckoned as a force pushing it in) is

$$(p + \delta p)(r + \delta r)\theta - pr\theta,$$

and this must be equal to the resultant of the forces arising from hoop stress, namely to

$$p'\delta r \cdot \theta.$$

Hence
$$(p + \delta p)(r + \delta r) - pr = p'\delta r,$$

or
$$p\delta r + r\delta p = p'\delta r,$$

which may also be written

$$\frac{d}{dr}(pr) = p'.$$

A further relation between p and p' is got by considering the strains. Unless the cylinder be very short the strain must be of such a character that plane sections taken transverse to the length remain plane when strained: in other words the longitudinal strain is uniform. Assume further that the cylinder has free ends. Then the longitudinal strain is entirely due to the lateral action of the two stresses p and p' , and its amount is

$$\frac{p}{\sigma E} + \frac{p'}{\sigma E}.$$

Hence to make the longitudinal strain constant we must have

$$p + p' = 2a,$$

where $2a$ is a constant.

If we assume that the cylinder instead of having free ends is subjected to a uniformly distributed longitudinal stress p'' , the longitudinal strain is the sum of the direct effect of p'' and the lateral effect of p and p' , and in that case also the condition of constant longitudinal strain requires that the sum of p and p' shall be constant.

We have then the two equations

$$p + p' = 2a,$$

and

$$p\delta r + r\delta p = p'\delta r.$$

Substituting $2a - p$ for p' and multiplying by r , this second equation becomes

$$r^2 \delta p + 2pr \delta r = 2ar \delta r,$$

or
$$\frac{d}{dr}(pr^2) = 2ar.$$

Integrating,
$$pr^2 = ar^2 + b,$$

or
$$p = a + \frac{b}{r^2},$$

where b is another constant.

Also
$$p' = 2a - p = a - \frac{b}{r^2}.$$

The constants a and b are to be found by considering the boundary conditions.

In the ordinary case of a thick cylinder exposed to internal pressure only, let p_i be the internal pressure and let the internal and external radii be r_1 and r_2 respectively. Then $p = p_i$ when $r = r_1$, $p = 0$ when $r = r_2$.

Hence
$$b = \frac{p_i r_1^2 r_2^2}{r_2^2 - r_1^2},$$

$$a = \frac{-p_i r_1^2}{r_2^2 - r_1^2}.$$

Hence the hoop stress at any radius r is

$$p' = \frac{-p_i r_1^2 \left(1 + \frac{r_2^2}{r^2}\right)}{r_2^2 - r_1^2},$$

the negative sign showing that it is a tension.

The hoop tension has its greatest value at the inner surface, when $r = r_1$. We there have

$$p_1' = \frac{-p_i (r_1^2 + r_2^2)}{r_2^2 - r_1^2}.$$

At the outer surface it is

$$\frac{-2p_i r_1^2}{r_2^2 - r_1^2}.$$

Thus if f represent the greatest safe tensile stress which the material of the cylinder will stand, the greatest safe internal pressure is

$$\frac{f(r_2^2 - r_1^2)}{r_1^2 + r_2^2}.$$

It should be noticed that the hoop tension is always greater than the internal pressure, no matter how thick the cylinder is.

We have assumed throughout that the stresses lie within the elastic limit and that the cylinder is free from initial internal stress. The formulas are applicable to the design of the cylinders of hydraulic presses and other thick tubes intended to resist internal pressure.

Fig. 137 (p. 216) illustrates by the curve AB the variation of hoop tension in a tube whose external diameter is three times its internal diameter. It will be noticed that the external portion of the metal is under comparatively little hoop tension and consequently contributes comparatively little to the strength.

144. Thick Cylinder exposed to External Pressure. If the exterior is exposed to a radial pressure p_e and the inside is free from pressure, these boundary conditions give the following equations for the constants a and b , r_1 and r_2 being the internal and external radii as before:

$$b = \frac{-p_e r_1^2 r_2^2}{r_2^2 - r_1^2},$$

$$a = \frac{p_e r_2^2}{r_2^2 - r_1^2}.$$

Hence in that case the hoop stress at any radius r is

$$p' = \frac{p_e r_2^2 \left(1 + \frac{r_1^2}{r^2}\right)}{r_2^2 - r_1^2}.$$

As this has the same sign as p_e , it represents a circumferential pressure. It increases towards the inner surface, and there, when $r = r_1$, it has the value

$$\frac{2p_e r_2^2}{r_2^2 - r_1^2}.$$

145. Use of Initial Internal Stress in strengthening a thick tube. We may make the external portion of a thick tube more effective for the purpose of standing pressure from within if we arrange that there shall be a condition of initial internal stress, of such a kind that the outer layers are tending to contract over the inner layers. This throws the inner layers into a state of initial hoop pressure, and when the pressure of the fluid inside the tube

becomes operative, its first effect is to relieve them of this initial pressure and to throw additional tension on the external layers.

One way in which a helpful condition of initial stress may be produced is to build up the tube out of two or more superposed layers, the outer being shrunk on over the inner. This device has been applied in the construction of big guns. The outer tube is bored to a diameter somewhat smaller than that of the barrel over which it is to be placed. It is then heated until it expands sufficiently to slip over the barrel, and as it cools its contraction makes it press on the barrel below, producing hoop tension in itself and hoop pressure in the barrel. Then when any pressure is applied inside the tube its effects in producing hoop tension are superposed on the existing hoop stresses, with the result that the outer portion of the compound tube becomes more severely stressed than it would be if no initial stress existed, and the inner portion is less severely stressed, since its hoop tension is reduced by the initial stress there. By this means the general distribution of stress due to internal pressure is considerably equalised. It is evident that this method of equalising the stress may be carried further by building up the whole tube in the form of a series of rings each shrunk on above those below it, and in gun-making it was at one time customary to shrink a series of tubes one above another.

Confining our attention to the simple case where the cylinder is built up of two tubes, let p_o be the radial pressure at the surface between them, due to the shrinking on of the outer tube, apart from any stress that may be caused by application of pressure within the bore of the inner tube. Then the results arrived at in the last paragraph show that the condition of initial stress in the compound tube is as follows. In the inner portion, from radius r_1 to radius r_2 , there is circumferential stress (of pressure) equal to

$$\frac{p_o r_2^2 \left(1 + \frac{r_1^2}{r^2}\right)}{r_3^2 - r_1^2}.$$

In the outer portion, whose radii are r_2 (internal) and r_3 (external) there is circumferential stress (of tension) equal to

$$\frac{-p_o r_2^2 \left(1 + \frac{r_3^2}{r^2}\right)}{r_3^2 - r_2^2}.$$

Now suppose that the compound cylinder as a whole, with internal radius r_1 and external radius r_3 , is thrown into a state of stress by the application of an internal pressure p_i .

The hoop stress which this would cause at any radius r , apart from initial stresses, is

$$\frac{-p_i r_1^2 \left(1 + \frac{r_3^2}{r^2}\right)}{r_3^2 - r_1^2}.$$

The actual hoop tension is to be found by taking the sum of this and of the initial circumferential stress.

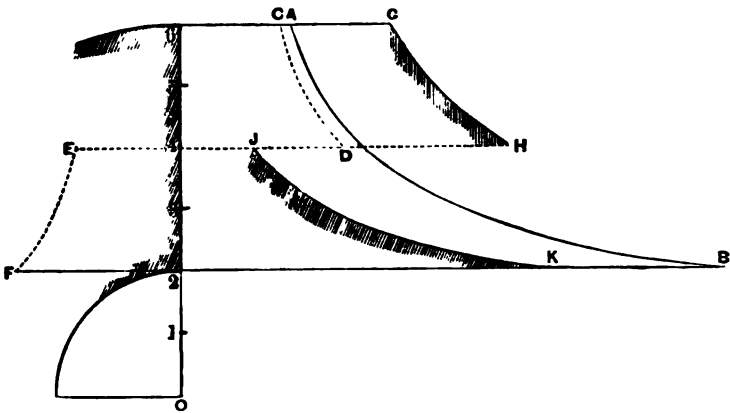

Fig. 137.

Fig. 137 illustrates this summation for a particular case. It is there assumed that $r_3 = 3r_1$ and $r_2 = 2r_1$. The inner tube has a bore of 2 inches radius; its external radius is 4 inches, and on this an outer tube with an external radius of 6 inches is shrunk on. The dotted curves CD and EF represent the initial states of circumferential stress set up in the outer and inner tubes respectively by the shrinking on. The curve AB represents the hoop tension which would be caused in the tube as a whole, if it were free from internal stress, when an internal pressure is applied equal in this example to seven times the pressure at the surface of contact of the two tubes. The curves GH and JK represent the resulting actual state of hoop tension. There is of course a discontinuity in the hoop stress as we pass from one tube to the other.

The numerical results of this example are stated in the following tables. The radial pressure produced by shrinking on, p_o , is taken as unity, and $p_i = 7p_o$.

Circumferential Stress in Compound Cylinder.

	Radius	Hoop pressure due to p_o	Hoop tension due to p_o	Hoop tension due to p_i	Resulting hoop tension
Inner Tube	2	2.67		8.75	6.08
	3	1.93		4.37	2.44
	4	1.67		2.84	1.17
Outer Tube	4		2.60	2.84	5.44
	5		1.95	2.13	4.08
	6		1.60	1.75	3.35

The advantage of the initial internal stress is obvious when a comparison is made between the two last columns of the table. It reduces the greatest hoop tension from 8.75 to 6.08 by throwing a larger share of duty on the outer layer of material. By division of the tube into three or more parts, with appropriate pressure at each surface of division, a more equal distribution could be secured. In all cases the state of initial stress must of course satisfy the condition that the total hoop pressure and total hoop tension due to initial stress are equal.

In the modern method of gun-making a long strip of steel tape is coiled over a barrel to form the compound tube. By regulating the tension under which the steel strip is wound on the barrel a suitable condition of initial internal stress is produced*.

146. Stress in a Revolving Ring. The problem of finding the circumferential stress in a revolving ring, due to the action of centrifugal force, is so closely analogous to the problem of the boiler shell that it will be convenient to mention it here.

Consider a short portion of the ring, subtending a small angle θ at the centre. Let s be the area of section, ρ the density, and r the radius. When the ring is revolving with a velocity v , the centrifugal force on this piece, expressed in gravitational units, is

$$\rho sr \theta \cdot \frac{v^2}{rg},$$

* The student is referred in this connection to articles by Prof. Greenhill in *Nature*, vol. XLII. pp. 304, 331, 378.

and this is balanced by the resultant of the two tensions at the extremities of the piece, namely

$$fs\theta$$

where f is the intensity of the circumferential tension. Thus

$$fs\theta = \frac{\rho sr\theta v^2}{rg},$$

or

$$f = \frac{\rho v^2}{g},$$

a result which shows that the hoop tension due to centrifugal force in a revolving ring depends only on the circumferential velocity and is independent of the radius of the ring. Thus in a running belt the tension, so far as it is due to centrifugal force, is independent of the size of the pulleys, and is the same in the straight and curved parts of the belt. In a steel ring, the density of which is 0.28 lbs. per cubic inch, a velocity of 567 feet per second produces a hoop tension of 15 tons per square inch.

147. Stress in a Revolving Disc. A more difficult problem is presented by a revolving disc. The following solution is substantially accurate when the disc is thin, and of uniform thickness. We have two principal stresses to deal with at any point, namely the radial stress p and the hoop stress p' . We shall use the positive sign for tensile stress and shall express the stresses in absolute units to avoid the introduction of g into the equations.

Let ω be the angular velocity of the disc,

ρ its density,

E Young's modulus,

μ Poisson's ratio, namely $\frac{1}{\sigma}$,

u the displacement of any point at radius r in the direction of the radius, due to the strain.

Taking a small element of the disc with radii r and $r + \delta r$ and with radially directed sides, the equilibrium of the element requires that the centrifugal force, which is $\rho\omega^2 r$ per unit of volume, shall be balanced by the resultant of the hoop tensions p' on the sides of the element together with the difference of radial stress on the outer and inner faces of the element. This gives an

equation between p and p' analogous to that in § 143 with the addition of a term due to the centrifugal force, namely

$$p' = \frac{d}{dr}(pr) + \omega^2 \rho r^2 \dots\dots\dots (1).$$

Next consider the strains. The strain in the direction of the hoop stress is $\frac{u}{r}$ and the strain in the radial direction is $\frac{du}{dr}$. Hence

$$\frac{Eu}{r} = p' - \mu p \dots\dots\dots (2),$$

and
$$E \frac{du}{dr} = p - \mu p' \dots\dots\dots (3).$$

Combining (2) and (3) we have

$$p' = \frac{E}{1 - \mu^2} \left(\frac{u}{r} + \mu \frac{du}{dr} \right) \dots\dots\dots (4),$$

$$p = \frac{E}{1 - \mu^2} \left(\frac{\mu u}{r} + \frac{du}{dr} \right) \dots\dots\dots (5).$$

Substituting these expressions for p and p' in (1),

$$r \frac{d^2u}{dr^2} + \frac{du}{dr} - \frac{u}{r} + \frac{(1 - \mu^2) \omega^2 \rho r^2}{E} = 0 \dots\dots\dots (6).$$

This gives, on integration,

$$\frac{u}{r} = \frac{C}{r^2} + C_1 - \frac{(1 - \mu^2) \omega^2 \rho r^2}{8E} \dots\dots\dots (7),$$

$$\frac{du}{dr} = -\frac{C}{r^3} + C_1 - \frac{3(1 - \mu^2) \omega^2 \rho r^2}{8E} \dots\dots\dots (8).$$

We have now to eliminate the constants by applying boundary conditions. Two cases have to be distinguished, namely the case of a complete or solid disc, and that of a disc with a hole in the centre.

Taking first the disc with a hole in it, let r_1 be the radius of the disc and r_0 the radius of the hole. Then $p = 0$ when $r = r_1$ and also when $r = r_0$. Applying these conditions in (4) and (5) we obtain

$$p' = \frac{\omega^2 \rho}{8} \left\{ (3 + \mu) \left(r_1^2 + r_0^2 + \frac{r_1^2 r_0^2}{r^2} \right) - (1 + 3\mu) r^2 \right\} \dots\dots (9),$$

and
$$p = \frac{\omega^2 \rho}{8} (3 + \mu) \left(r_1^2 + r_0^2 - \frac{r_1^2 r_0^2}{r^2} - r^2 \right) \dots\dots\dots (10).$$

From (9) it follows that the hoop stress has its greatest value at the circumference of the hole, namely

$$\text{Greatest } p' = \frac{\omega^2 \rho}{4} \{(3 + \mu) r_1^2 + (1 - \mu) r_0^2\} \dots\dots(11).$$

And in the particular case where the hole is very small this becomes

$$\frac{\omega^2 \rho}{4} r_1^2 (3 + \mu).$$

In the second case, that of a disc without a hole, the conditions are that $p = 0$ when $r = r_1$ and $u = 0$ when $r = 0$.

Applying this latter condition in (7) we have $C = 0$ and

$$u = C_1 r - \frac{(1 - \mu^2) \omega^2 \rho r^3}{8E} \dots\dots\dots(12),$$

$$\frac{du}{dr} = C_1 - \frac{3(1 - \mu^2) \omega^2 \rho r^2}{8E} \dots\dots\dots(13).$$

By substituting these values in (5) and applying the condition that $p = 0$ when $r = r_1$,

$$C_1 = \frac{(1 - \mu)(3 + \mu) \omega^2 \rho r_1^2}{8E} \dots\dots\dots(14).$$

Hence, by (4),

$$p' = \frac{\omega^2 \rho}{8} \{(3 + \mu) r_1^2 - (1 + 3\mu) r^2\} \dots\dots\dots(15),$$

and

$$p = \frac{\omega^2 \rho}{8} (3 + \mu) (r_1^2 - r^2) \dots\dots\dots(16).$$

Each of these stresses is a maximum at the centre, the maximum value being

$$\frac{\omega^2 \rho}{8} r_1^2 (3 + \mu).$$

Hence the greatest hoop tension in a disc without a hole is just half that which exists when there is a small hole.

These results show that if a thin disc of steel will bear safely a stress of 15 tons per square inch it may, when it has a hole in the centre, be whirled with a peripheral velocity of about 620 feet per second, and when there is no hole the speed may be increased to about 870 feet per second. It will be obvious that the strength of a disc to resist whirling is improved by giving it extra thickness in the neighbourhood of the nave, where the hoop tension is greatest.

CHAPTER XII.

HANGING CHAINS AND ARCHED RIBS.

148. Loaded Chain. When a perfectly flexible chain or rope is acting as a suspension bridge to support weights, the condition that there can nowhere be any bending moment requires that at each point where weight is applied there must be equilibrium between three forces, namely the weight and the pull exerted by the chain on either side of the point.

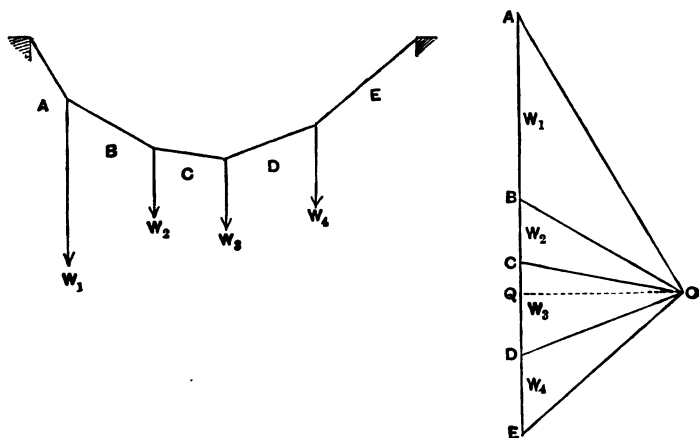

Fig. 138.

Let $ABCDE$ be the chain carrying W_1, W_2, W_3, W_4 , as sketched in fig. 138. Then the pulls in the chain at A and B must equilibrate W_1 , and so on. Hence the form in which the chain hangs must be such that lines drawn from any point O parallel to the successive sections of the chain will divide a vertical "line of loads" AE into segments $AB, BC, \&c.$ which

represent the loads $W_1, W_2, \&c.$ The lines $OA, OB, \&c.$ represent the pulls in corresponding portions of the chain. Further if a horizontal line through O be drawn to meet the line of loads in Q , AQ and BQ represent the proportion in which the whole load is borne by the two piers, and OQ represents H , the horizontal component of the pull, which is constant throughout the chain.

This construction allows us to determine a system of loads which will give an assigned form to the chain. The form is evidently unchanged when all the loads are altered in the same ratio—a process which is equivalent to moving the line of loads nearer to or further from O .

The converse problem is, given a system of loads, the distance of their lines of application from the piers being assigned, to find the form which will be taken by a chain carrying them. To solve this, find by the method of moments or otherwise the proportion of vertical load borne by each of the piers. Draw a line of loads $AB, BC, \&c.$ and divide it in this proportion in Q . From Q draw a horizontal line and take any point O in it. Join O with $A, B, \&c.$, and draw a chain, the successive sections of which are parallel to $OA, OB, \&c.$

Any chain drawn thus will be in equilibrium under the given system of loads, and to make the problem definite some further condition must be assigned, as for instance that the chain is to have a certain length, or that the horizontal pull between the piers is to have a certain value, in which case the length of QO in the force diagram is given.

When load is continuously distributed, the chain forms a continuous curve. The tension T at any point is equal to $H \sec i$, where i is the inclination of the chain there to the horizontal. H is the tension at the lowest point. Any portion of the chain

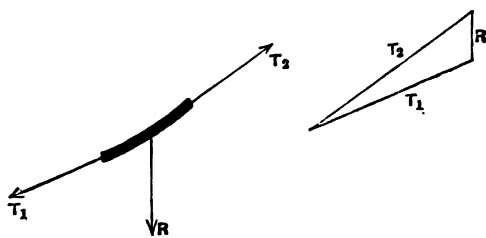

Fig. 139.

is in equilibrium under the tangential pulls T_1, T_2 , at its ends and the resultant load R carried by that portion (fig. 139). Thus the tangents when produced meet in the line of action of R .

149. Parabolic Chains. A case of considerable practical interest is that in which the chain bears a continuously distributed load which is uniform per foot run of the span.

Taking the origin at the lowest point of the chain, the total load borne by any arc AB (fig. 140) is $wAM = wx$, w being the load per foot run of the span. This load acts through V , the middle point of AM . The tangent at B meets AM in V and consequently bisects AM . Hence

$$\frac{y}{\frac{1}{2}x} = \frac{wx}{H},$$

$$y = \frac{wx^2}{2H},$$

an equation which shows that the form of the chain is a parabola.

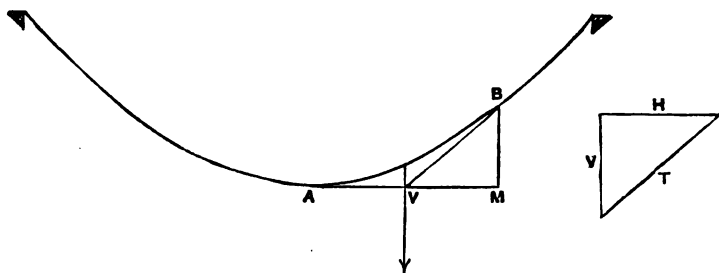

Fig. 140.

Writing c for the horizontal distance of the pier from A , and d for the depth of the vertex below the pier, we have

$$H = \frac{wx^2}{2y} = \frac{wc^2}{2d}.$$

The tension at any point

$$T = \sqrt{H^2 + w^2x^2},$$

and at the ends, where the tension is greatest, this becomes

$$wc \sqrt{\frac{c^2}{4d^2} + 1}.$$

It is convenient to remember that the half length of a parabolic curve, from the vertex to either extremity, is approximately

$$s = c + \frac{2d^2}{3c},$$

and hence, if the half length undergoes a small change δs , say through strain or through change of temperature, the amount by which the chain will sag is approximately

$$\frac{3c\delta s}{4d}.$$

If the piers are unequally high, we have distinct values for $c_1, c_2; d_1, d_2; s_1, s_2$. Since

$$d_1 : d_2 = c_1^2 : c_2^2,$$

$$c_1 = \frac{(c_1 + c_2)\sqrt{d_1}}{\sqrt{d_1} + \sqrt{d_2}} = \frac{L\sqrt{d_1}}{\sqrt{d_1} + \sqrt{d_2}},$$

an equation which serves to determine the position of the vertex when the span L and the heights of the piers are known.

These results have application in the design of suspension bridges, where the total load supported by the chain, including its own weight, is nearly uniform per foot run of the span. Another application is to determine the stress in a telegraph wire, due to its own weight or to a load of snow. Strictly, in such a case the load is uniform per foot of the wire's length, but so long as the inclination is small there is no material difference between that and a load which is uniform per foot run of the span. The case of a load uniform per foot of the chain's length has little interest except as an exercise in applied mathematics. Its solution is given in the next article.

150. Common Catenary: Uniform Chain loaded with its own weight. Here w is uniform per foot of length, not per foot of span. On any arc s the load is ws . The horizontal component of tension H may be represented as wm where m is a certain length. Using i as before to express the inclination at any point,

$$\frac{dy}{dx} = \tan i = \frac{ws}{wm} = \frac{s}{m}.$$

Then
$$\frac{ds}{dx} = \sqrt{1 + \left(\frac{dy}{dx}\right)^2} = \frac{1}{m} \sqrt{m^2 + s^2},$$

or
$$\frac{\delta x}{m} = \frac{\delta s}{\sqrt{m^2 + s^2}}.$$

Integrating,
$$\frac{x}{m} = \log_e (s + \sqrt{m^2 + s^2}) + C.$$

Since $s = 0$ when $x = 0$, $C = -\log_e m$, and

$$\frac{x}{m} = \log_e \frac{s + \sqrt{m^2 + s^2}}{m},$$

or
$$s + \sqrt{m^2 + s^2} = m e^{\frac{x}{m}}.$$

Hence
$$s = \frac{m}{2} \left(e^{\frac{x}{m}} - e^{-\frac{x}{m}} \right) = m \sinh \frac{x}{m}.$$

Also
$$\frac{dy}{dx} = \frac{s}{m} = \sinh \frac{x}{m},$$

from which
$$y = m \cosh \frac{x}{m} - m,$$

the constant of integration being $-m$ since $y = 0$ when $x = 0$.

This is the equation to the common catenary, taking the origin at the vertex.

A neater expression is obtained by shifting the origin to a point at a distance m below the vertex. Then calling y' the new ordinate,

$$y' = m \cosh \frac{x}{m}.$$

The tension at any point is

$$\begin{aligned} T &= \sqrt{H^2 + w^2 s^2} = w \sqrt{m^2 + s^2} \\ &= w m \sqrt{1 + \sinh^2 \frac{x}{m}} = w m \cosh \frac{x}{m} \\ &= w y'. \end{aligned}$$

That is to say, the tension at any point is equal to the weight of a chain whose length is the vertical distance of the point from a horizontal line drawn at a distance m below the vertex.

Taking the origin again at the vertex, we have

$$y + m = m \cosh \frac{x}{m}.$$

Also
$$s^2 = m^2 \sinh^2 \frac{x}{m}.$$

Hence

$$m^2 + s^2 = m^2 \left(1 + \sinh^2 \frac{x}{m} \right) = m^2 \cosh^2 \frac{x}{m} = (y + m)^2,$$

$$y = \sqrt{s^2 + m^2} - m,$$

and

$$m = \frac{s^2 - y^2}{2y},$$

an equation which enables m to be found when the data are the length and the dip of the chain. When the data are the span and the dip, or the span and the length, the value of m may be found by trial from the equation given above. The following table gives the ratio of m to the span corresponding to various dips, which are stated as fractions of the span :

Dip ÷ span	$\frac{1}{8}$	$\frac{1}{10}$	$\frac{1}{12}$	$\frac{1}{14}$	$\frac{1}{16}$	$\frac{1}{18}$	$\frac{1}{20}$
$m \div$ span	1.023	1.270	1.518	1.766	2.013	2.261	2.508.

As an example, take the case of a wire stretched between level supports with a span of 1000 feet and a dip of 100 feet. The stress at the middle, or mw , is $1270w$, w being the weight of the wire per foot. If the curve were treated as a parabola the calculated stress at the middle would be $\frac{wc^2}{2d}$ (§ 149) or $1250w$.

This will show that even when the dip is as much as one-tenth of the span no material error results from treating the distribution of weight as uniform per foot run of the span.

151. Suspension Bridge with Stiffening Girder. The flexibility of the hanging chain causes it to change its shape under moving loads and this is a serious drawback to the use of suspension bridges. If the platform is also flexible it may be thrown into a state of dangerous oscillation, especially when variations of load are repeated periodically, as happens for example when troops are marching over the bridge. The structure may however be stiffened by the use of auxiliary girders for that purpose. These girders are usually arranged in the manner indicated in fig. 141. Each chain carries a pair of stiffening girders, the length of which is equal to half the span. They are hinged to one another by a pin at the middle M , and they rest on the piers

by pins O and Q which are allowed sufficient freedom to slide in the direction of the span, and are held from rising as well as from

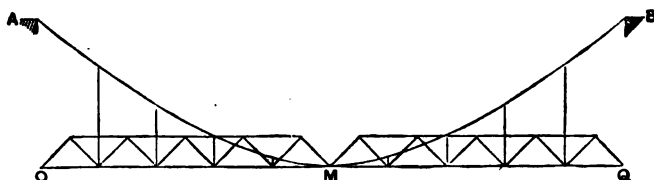

Fig. 141.

falling, because with some distributions of load they may tend to rise.

A single stiffening girder without a central hinge has also been used, but this has the disadvantage that the stresses on it depend on the initial tightness of the chain, and are much affected if through changes of temperature or any other reason the chain becomes tighter or slacker. With a central joint, the stress in each part of the structure is at once determinate, and does not change, except to a trifling extent, when the relative lengths of the various pieces are altered by changes of temperature or other causes.

To investigate the distribution of the load between the chain itself and the stiffening girder, when the girder is hinged, we may proceed as follows.

The forces on each girder are the loads it carries, acting downwards, the pulls of the suspension rods, acting upwards, and the forces on its ends at the pins acting either downwards or upwards. These forces produce, in general, bending moment at any section of the girder. The bending moment on the jointed girders is zero at the ends and at the central hinge.

We have seen in § 92 that the curve of a hanging chain is a diagram of bending moments for the load carried by the chain. Applying that principle to the chain with a stiffened girder, it is evident that the pulls of the suspension rods must always adjust themselves in such proportions, no matter how the load varies, as to make the curve of the chain represent a bending moment diagram for them, considered separately. In other words, out of the whole load carried by the structure, the chain carries directly, distributed through the suspension rods, as much as will constitute a system

having a bending moment diagram of the shape of the chain. Hence if we draw a diagram of bending moments for the complete system of loads which the structure carries as a whole, and subtract from that a diagram of bending moments having the shape of the chain (using the appropriate scale so that this latter diagram will represent the bending moments due to the pulls of the suspension rods), then the difference between the two diagrams will show the bending moments which have to be borne by the stiffening girders.

The diagrams may be drawn superposed, so that their differences are found graphically. The scale on which the curve of the chain represents a diagram of bending moments is to be determined with reference to the consideration that the resulting moment on the girder is zero at the central hinge. Consequently the total load diagram of moments must intersect the chain-load diagram of moments (that is, the chain curve) at the point which corresponds to the position of the hinge.

An example will make this construction more intelligible. Let the curve OCQ represent the given form of the chain, which is drawn inverted so that it may resemble the bending moment diagrams with which the student is familiar. This curve represents, on a certain scale which we do not at first know, a diagram of

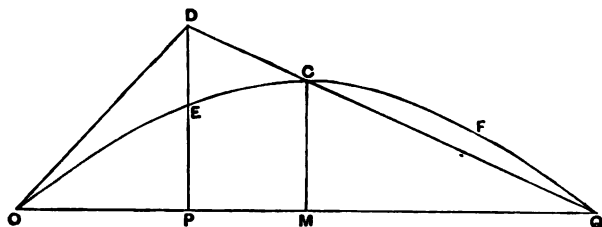

Fig. 142.

bending moments for what has been called here the chain-load, that is to say, that part of the load which the chain carries in consequence of the pulls in the suspension rods. Now let a bending moment diagram be drawn for the whole load carried by the structure. Draw that on the same base, selecting for it such a scale as will make that diagram intersect the other at the place where the hinge comes in the jointed girder (namely, at the middle of the span). The scale thus chosen is the scale on which both diagrams are to be interpreted. The difference between the two diagrams gives, on the same scale, the bending moments on

the jointed girders. Thus, in fig. 142, let the load consist simply of a single concentrated load applied at a point P distant a from one end of the span, and b from the other. The diagram of such a load is a triangle, with the vertex over P , and we have to draw this triangle so that the side DQ shall intersect the chain curve at C , the place corresponding to the hinge. Hence the diagram is to be drawn by joining QC , and producing it to meet a vertical line through P in D , and then joining OD . The value of DP as a bending moment is known, being $\frac{Wab}{L}$ where L is the span.

This determines the scale of moments for the figure. The overlapping pieces ODC and CFQ are then the bending moment diagrams of the two girders. The right-hand girder in this case bears negative moments: that is to say it is bent up by the pull of the suspension rods on it, and is held down at its ends by the pins there. Having in this way determined the bending moments on the girders we may go on to find the shearing forces $\left(\frac{dM}{dx}\right)$. The shearing forces at the ends and middle of the span are the forces which have to be borne by the pins.

This construction is applicable to any form of chain curve, and may be used to determine the bending moments and shearing forces which have to be provided for under any assumed distribution of load, and also the pulls in the suspension rods. If we assume that the form of the chain is a parabola, the pulls in the suspension rods are equivalent to a uniformly distributed load, and the case represented in fig. 142 may be expressed algebraically thus:

Let w represent the load per foot run which is equivalent to the pulls of the suspension rods. Then CM represents, in the diagram of bending moments, a moment equal to $\frac{wL^2}{8}$. The load W applied at P produces there a moment DP equal to $\frac{Wab}{L}$, and at the middle a moment CM equal to $\frac{Wa}{2}$. Hence, since the joint is at the middle,

$$\begin{aligned} \frac{wL^2}{8} &= \frac{Wa}{2}, \\ w &= \frac{4Wa}{L^2}, \end{aligned}$$

which determines the amount of pull in the suspension rods when the number of the rods is known. The greatest bending moment M_p to be borne by the left-hand girder, for this position of the load, is DE , or $DP - EP$.

But $DP = \frac{Wa(L-a)}{L}$ and $EP = \frac{wa}{2}(L-a)$, and substituting $\frac{4Wa}{L^2}$ for w we obtain, for the bending moment at P on the stiffening girder,

$$M_p = WL \left(\frac{a}{L} - \frac{3a^2}{L^2} + \frac{2a^3}{L^3} \right).$$

To find the position of the load which will make this moment a maximum we write $\frac{dM_p}{da} = 0$, which gives

$$a = \frac{L}{2} \left(1 \pm \frac{1}{\sqrt{3}} \right) = 0.211L, \text{ or } 0.789L.$$

The maximum moment to be borne by the stiffening girder is then readily found to be

$$0.096 WL.*$$

This is the maximum positive bending moment which each girder will have to bear when a load W moves across the bridge. The maximum negative moment occurs at the middle of each girder when the load is at the middle of the span. Its value (fig. 143) is

$$\begin{aligned} FG &= FN - GN = \frac{1}{4} CM \\ &= \frac{1}{8} WL. \end{aligned}$$

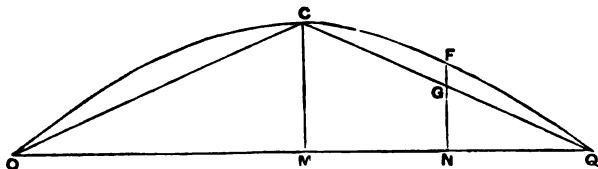

Fig. 143.

The student will find it instructive to extend this method of determining the moments on the stiffening girders to the case of a uniform advancing load.

* This quantity is only very little greater than the moment produced by placing W in the middle of the half girder, namely $\frac{1}{8} WL$.

152. Inverted Chain. The Arch. Imagine a chain consisting of a series of stiff jointed rods, loaded at the joints, to be inverted so that it forms an arch, the form of the chain and the distribution of loads remaining unchanged. The chain is still in equilibrium, but its equilibrium is now unstable. Each

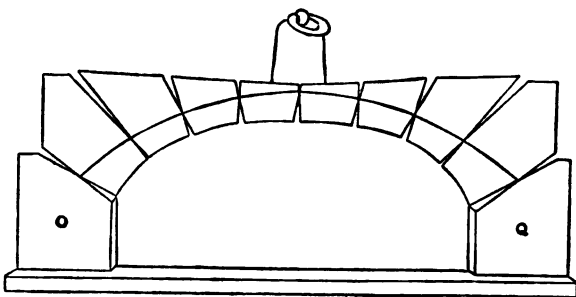

Fig. 144.

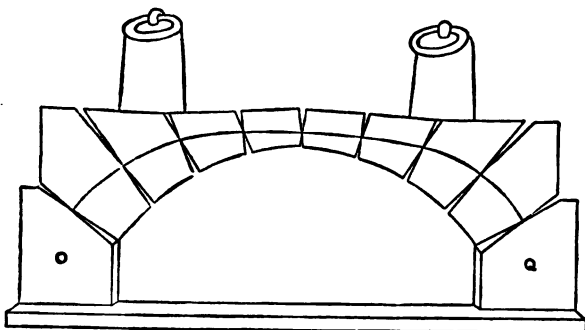

Fig. 145.

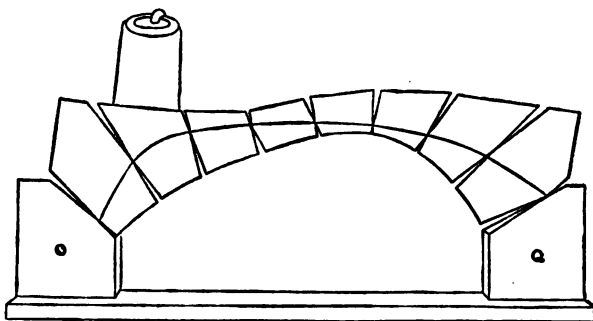

Fig. 146.

rod is now exerting thrust, instead of pull, and at each joint the thrusts of the two rods meeting there equilibrate the load applied

at the joint. But any variation in the distribution of load or any casual disturbance of the form of the chain upsets this balance and the arch yields.

Next suppose that in place of being made up of jointed rods the arch is composed of blocks or "voussoirs" as in the model shown in fig. 144. In that model the voussoirs have slightly curved surfaces which allow them to rock to some extent on one another, thereby exaggerating the action which the elastic compressibility of the material permits in an arch of stone blocks with flat faces. It is clear that this rocking action gives the arch a stability which was not possessed by the inverted chain of rods. The loads may alter, or the form of the arch may be disturbed, to a limited extent, without causing the structure to break down. Each voussoir remains in equilibrium provided that the vertical force made up of its own weight and any load applied to it can be balanced by the two forces which are exerted upon by its neighbours through the joints between it and them. A continuous line may be drawn to represent the direction of the thrust at all the joints as in fig. 144. This is called the linear arch: it represents the form of an inverted chain carrying the same system of loads.

When the distribution of load is altered, the voussoirs turn slightly with the effect that the linear arch takes a form which is proper for the new distribution. In fig. 144 we have, besides the general load due to the weight of the voussoirs, an extra load at the crown, and consequently the linear arch rises there, just as a chain already in equilibrium under a distributed load would sag more considerably wherever an extra load was applied. Similarly in fig. 145 the linear arch rises at the haunches to meet extra loads applied there, and is flat at the crown, while in fig. 146 it rises to meet the load on one haunch. Precisely similar changes occur in the form and position of the linear arch in a ring of stone voussoirs, although there the absence of curvature at the joints prevents the action from being visible as it is in the model with curved blocks*. When the linear arch deviates from the middle of any joint, the resultant stress is no longer axial, and the varying distribution of stress on the surface then causes a varying

* Figs. 144-146 are due to Fleeming Jenkin, and are copied from his article "Bridges" in the *Encyclopaedia Britannica*.

amount of elastic compression which implies, in effect, some turning on the part of each voussoir.

The limits of loading within which the structure remains stable are determined by the consideration that the linear arch may not pass outside of any joint. If, for instance, in fig. 146 the load on the left were increased, one of the joints between the crown and the right-hand abutment would open because the linear arch would reach the inner extremity of the joint. Besides this condition, it is evidently necessary that the blocks should not slip on one another at the joints: in other words the direction of the linear arch at each joint must not make with the normal an angle greater than the angle of repose. In the model the joints are roughened to allow the linear arch to be largely displaced without causing slip.

For reasons which have been explained in § 82, the rule is generally followed in the design of large stone arches that the linear arch be not required to pass outside the middle third of each joint. When this requirement is satisfied the effect is that all the surface at each joint is in compression, with an intensity which may range from zero at one edge to a maximum at the other. An obvious further practical condition is that the joints should be wide enough, in relation to the load, to prevent the greatest intensity of this compressive stress from exceeding a safe value.

153. Arched Rib. A stiff rib, say of metal, shaped in the form of an arch, differs from a ring of individual voussoirs in this respect, that the linear arch need not lie within the section of the rib. In other words, the resultant of the stress at any section of the rib may lie outside of the section, because the rib is capable of sustaining bending moments. When the position of the linear arch is known, and the amount of the thrust in it, it is easy to find the bending moment which acts at any section of the rib. Each section has, in general, to bear bending moment, direct thrust, and shearing stress. We shall consider a rib carrying vertical loads.

Let AB (fig. 147) be a section of the rib and let DE be drawn tangent to the linear arch at the same place. The resultant thrust F has the direction and position indicated by DE . This is equivalent to a parallel force applied at C , the centre of gravity of the section, together with a bending moment $F \cdot CE$, if CE

be drawn perpendicular to DE . The force F acting through C may be resolved parallel and perpendicular to the section. The

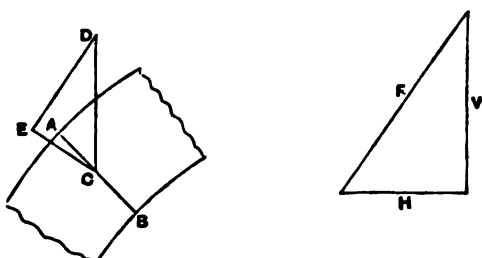

Fig. 147.

component parallel to the section causes shearing stress: the component perpendicular to the section causes a uniformly distributed stress of compression $\frac{F}{S}$ (S being the sectional area of AB), which has to be superposed on the stress due to the bending moment in finding the whole normal stress at any point of the section.

Now the thrust F at any point in the linear arch may be resolved into a vertical component V and a horizontal component H , of which H is constant for all points in the arch. Comparing the triangles FVH and DCE of fig. 147 we have

$$H : F = CE : CD.$$

Hence the bending moment, which is $F \cdot CE$, is equal to $H \cdot CD$. In other words, since H is constant, the height of the linear arch above or below the centre line of the rib constitutes a diagram of bending moments for the rib. The linear arch itself, as we have already seen in dealing with hanging chains, takes a form which is that of a diagram of the bending moments which the same system of loads would produce on a straight beam. Hence the problem of drawing the linear arch for the rib resolves itself into drawing a diagram of bending moments for a similarly loaded beam, with an appropriate scale and subject to the particular terminal conditions which apply in any given case.

154. Rib hinged at the ends and centre. We shall first take the comparatively simple case in which the rib is hinged at the ends and also at the crown (or to put it more generally) at one other point besides the ends (fig. 148). Wherever there is a

hinge the bending moment on the rib must be zero, if we leave out of account the trifling amount of bending which a hinge may

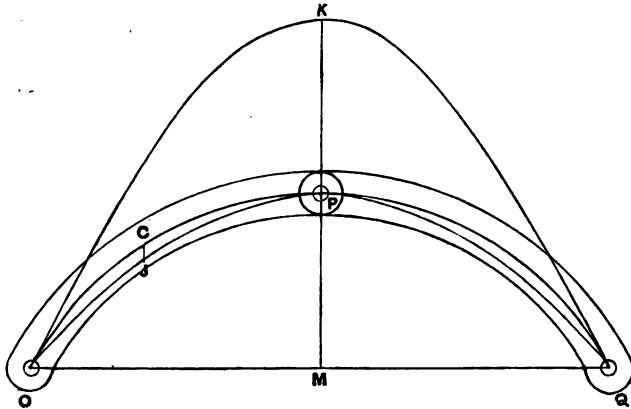

Fig. 148.

take in consequence of friction. Consequently the linear arch must pass through the centre of each hinge. We proceed to draw a diagram of bending moments for the given loads, considered as acting on a beam of the span OQ . If this diagram passed through the third hinge it would be the true linear arch, for in that case the condition would be satisfied that there is to be no bending moment on the rib at P , as well as at O and Q . In other words we have to select such a scale for the bending moment diagram, drawn on the base OQ , as will make it pass through P . This is readily done by first drawing it to any scale, say OKQ , and then reducing all the ordinates in the ratio $\frac{PM}{KM}$.

The linear arch $OJPQ$ having been found in this way, the distance JC between it and the central curve of the rib gives, on the same scale, the bending moment which has to be taken by the rib. The amount of the thrust F at any place is also determined, like the pull in a hanging chain, from the known form of the linear arch and the known values of the loads. Hence the stress at any section of the rib is found.

It will be clear that the construction by which the linear arch is found applies whether the loads are symmetrically or unsymmetrically distributed. The student will notice the correspondence between the problem of the hinged arch and that of the chain with hinged stiffening girder, treated in § 151.

155. Rib hinged at the ends only. In the case discussed in the last paragraph, namely that of a rib hinged at three places, the problem of finding the linear arch is perfectly determinate: the jointed rib cannot be self-strained as a whole, and with a given system of loads only one distribution of stress is possible. It is not affected by any yielding of the abutments, or by expansion or contraction of the rib through changes of temperature. But if the rib is hinged at the ends only it is clear that this is no longer true. The rib is bent if the span increases by any yielding of the abutments, or if, while the span remains fixed, the rib itself expands through heat. Hence it may be subject to bending moments apart from the effects of applied load. To make the problem of finding the linear arch determinate, we must introduce some assumption as to the initial state of stress before loads are applied and as to the fixity of the abutments. In what follows it will be assumed that the span does not alter, and that no stress exists in the rib except what is caused by applied loads.

With these assumptions the problem is determinate, and the linear arch is to be found from the consideration that the total effect of the elastic bendings which the loads cause in every part of the rib is such as to produce no change of span. In other words, that

$$\Sigma \delta x = 0$$

where δx is the horizontal displacement of one end of the rib, relatively to the other end, which results from the bending of any element of the rib, the sum of such displacements being

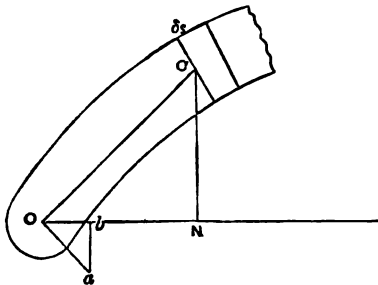

Fig. 149.

taken for all the elements. The linear arch must of course have its extremities in the hinged ends, as in previous cases, and it must be a diagram of bending moments for a similarly loaded

beam. The further consideration, that the bending must be such that $\Sigma \delta x = 0$, suffices to fix the height of the linear arch.

In order to consider the horizontal displacement of O due to any one element δs , taken alone, we must think of the portions of the arch lying to either side of the element as behaving for the moment like rigid bodies. Then if the position of the opposite end be considered fixed, the elastic bending of δs would cause O to move through a small distance Oa perpendicular to CO . The horizontal component of this displacement, or δx , due to the bending of δs , is Ob . Thus

$$\frac{\delta x}{Oa} = \frac{CN}{CO} = \frac{y}{CO}$$

where y represents the ordinate CN of the centre line of the rib.

Let M represent the bending moment acting on δs , then the angle through which the sides of δs turn relatively to one another in consequence of bending is

$$\frac{M}{EI} \delta s.$$

Hence

$$Oa = \frac{M \cdot CO \cdot \delta s}{EI},$$

and

$$\delta x = \frac{My \delta s}{EI}.$$

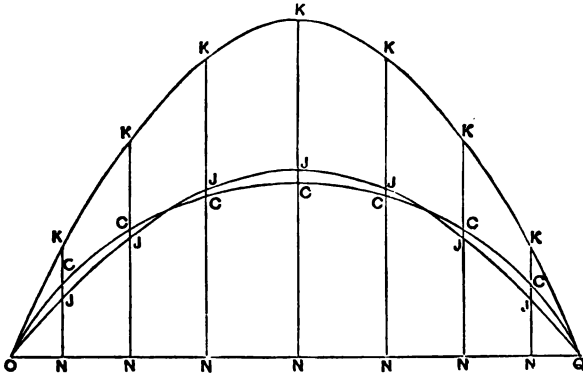

Fig. 150.

Hence the condition that the span is not to be altered by loading makes

$$\Sigma \frac{My \delta s}{I} = 0.$$

It should be added that we are here neglecting the direct effect of the compressive stress in each element in altering the span, an effect which is very small compared with that of bending.

Now the linear arch OJQ (fig. 150) is related to the centre line of the rib OCQ in such a manner that CJ is everywhere proportional to the bending moment on the rib. The condition that $\sum \delta x = 0$ may therefore be expressed

$$\sum \frac{CJ \cdot y \delta s}{I} = 0.$$

Suppose that the summation is made for a series of points taken at equal distances along the rib; we then have

$$\sum \frac{CJ \cdot y}{I} = 0.$$

But $CJ = JN - y$, and the condition becomes

$$\sum \frac{yJN - y^2}{I} = 0.$$

If a bending moment diagram OKQ for the beam carrying the given loads be drawn to any scale, its ordinate bears a constant ratio to those of the required linear arch, so that we may write

$$JN = rKN,$$

and

$$\sum \frac{y^2}{I} = \sum \frac{yJN}{I} = r \sum \frac{yKN}{I}.$$

Hence

$$r = \frac{\sum \frac{y^2}{I}}{\sum \frac{yKN}{I}},$$

a quantity which is readily calculated after measuring CN and KN at a series of equidistant sections. Thus when r is found the diagram OKQ is transformed into the required linear arch by changing its vertical scale in the ratio $r : 1$.

The procedure therefore is, to draw the curve of the rib, OCQ , and also on the same base a diagram OKQ of bending moments for the similarly loaded beam. Then taking a series of sections at equal distances along the arc of the rib measure CN and KN and calculate r , which gives the ratio in which the scale of the bending moment diagram is to be altered in order to give the linear arch. Then draw a second bending moment diagram OJQ to this altered scale. The distance CJ at any section measures on

that scale the bending moment which acts on the rib. The construction applies to unsymmetrical as well as to symmetrical loading.

156. Rib fixed at the ends. Here again we have to make certain assumptions without which the problem of finding the stress is indeterminate. We may assume as before that there is no initial stress, that is no stress except what is due to the loads, and that the abutments do not yield. The given condition that the ends are held fixed implies, in general, that when the rib is loaded there is some bending moment at each end. We shall take the rib to be symmetrical and symmetrically loaded, in which case the moment is the same at each end. Call it μ . Then the linear arch is a diagram of bending moments made up of (1) the moments in a beam carrying the same loads, and (2) the moment μ superposed on that: in other words the ordinate of the linear arch is

$$JN - \mu,$$

where JN is, as in fig. 150, the bending moment on a beam carrying the same system of loads. The end moment is negative because it tends to reduce the amount of bending such a beam would experience. Thus the linear arch retains the form which it has in a rib hinged at the ends, and is simply shifted downwards, parallel to itself, through a certain distance μ , which we have to find. Hence at any section of the rib the actual bending moment is now $M - \mu$, where M is, as in § 155, the moment in a rib with hinged ends. The condition that $\sum \delta x$ shall be zero still applies, and now leads to the result

$$\sum \frac{(M - \mu) y \delta s}{EI} = 0,$$

or

$$\sum \frac{(CJ - \mu) y \delta s}{I} = 0,$$

where J represents as before a point on what would be the linear arch for a rib with hinged ends. Since $CJ = JN - y$ and $JN = rKN$ this becomes

$$r \sum \frac{yKN}{I} - \sum \frac{y^2}{I} - \mu \sum \frac{y}{I} = 0 \dots \dots \dots (1),$$

summation being made at a series of equidistant sections along the rib from end to end.

The further condition that the inclination of the rib at the ends remains unchanged gives another equation involving the two unknown quantities r and μ . Taking any element δs along the rib, the bending in it considered alone would change the inclination of its ends, relatively to one another, by the amount

$$\frac{(M - \mu)}{EI} \delta s,$$

and hence
$$\Sigma \frac{(M - \mu)}{EI} \delta s = 0,$$

or
$$\Sigma \frac{(CJ - \mu)}{I} = 0$$

for a series of equidistant sections.

If we substitute $rKN - y$ for CJ this gives

$$r \Sigma \frac{KN}{I} - \Sigma \frac{y}{I} - \mu \Sigma \frac{1}{I} = 0 \dots \dots \dots (2).$$

The equations (1) and (2) together enable the quantities r and μ to be found.

If the loading is unsymmetrical we have different moments μ_1 and μ_2 at the left- and right-hand ends respectively, and at any intermediate point the true moment acting on the rib is

$$M - \mu$$

where

$$\mu = \mu_1 - \frac{x}{L} (\mu_1 - \mu_2),$$

L being the span and x the horizontal distance from the left-hand end. This quantity is to be introduced into the equation stated above, and a third relation is found by equating the sum of the vertical displacements of one end, or $\Sigma \delta y$, to zero, a condition which holds when (as here) the opposite end has its direction as well as its position fixed.

APPENDIX.

The following Tables contain a few representative data regarding the Strength and Elasticity of Materials.

I. *Strength to resist Tension.*

Tons per
square inch.

Wrought-iron :—

Finest Lowmoor and Yorkshire plates, tested in direction of rolling	27 to 29
Finest Lowmoor and Yorkshire plates, tested across direction of rolling	24
Staffordshire plates, in direction of rolling	26
" " across direction of rolling	24
Average good boiler plates, in direction of rolling	25
" " " " across direction of rolling	20
Ship plates, in direction of rolling	20 to 24
" " across direction of rolling	19
Finest Lowmoor and Yorkshire bars	24 to 29
Average good bars	25
Soft Swedish bars	20
Charcoal-iron wire, hard drawn	35 to 40
" " " annealed	about 30

Steel :—

Ordinary mild steel bars and plates with about 0·2 per cent. of carbon	28 to 32
Specially mild steel	24 to 36
Steel for rails, with about 0·4 per cent. of carbon	35 to 45
High carbon steel for springs, annealed	45 to 50
" " " tempered	60 to 70
Steel castings	15 to 45
" " annealed	25 to 35
Steel wire, ordinary	about 70
" " tempered	100

	Tons per square inch.
<i>Steel—continued:</i>	
Pianoforte steel wire	120 to 150
Nickel steel with about 5 per cent. of nickel, annealed ...	40
" " " 12 " " 	90
Chrome steel	80
Tungsten steel	72
Cast-iron	5 to 15
" " 	average about 8
Copper, cast	8 to 12
" rolled or forged	13 to 16
" wire, annealed	18 to 20
" " hard drawn	26 to 30
Copper with 0.2 to 0.4 per cent. of phosphorus	20 to 22
Ordinary yellow brass, cast (66 per cent. copper, 34 per cent. zinc)	10 to 12
Ordinary yellow brass, rolled	15 to 24
Brass wire	20 to 25
German-silver wire	30
Gun-metal (about 90 per cent. copper and 10 per cent. tin)	12 to 17
Phosphor bronze	16 to 18
" " wire, hard drawn	45 to 70
Aluminium, cast	4 to 6
" rolled	6 to 10
Aluminium bronze (90 per cent. copper, 10 per cent. aluminium)	40
Zinc, cast	1 to 3
" rolled	7 to 10
Lead	about 1
Tin	1 to 2½
Soft solder	3
<i>Timber tested in the direction of the fibre:—</i>	
Oak	3 to 7
White pine	1½ to 3½
Pitch pine	4
Riga fir	2½ to 5½
Ash	4 to 7
Beech	4 to 6
Teak	4 to 7
Spanish mahogany	4 to 7
Cement, set for 1 week	0.16
" " 1 year	0.24
Leather belting	2
Hemp rope	4 to 5

*II. Strength to resist Crushing.*Tons per
square inch.

Wrought-iron	16 to 20
Cast-iron	25 to 65
„ „ average	40 to 50
High-carbon steel, hardened by quenching	120 to 180
Brass	5
Timber	2 to 4
Cement	1½ to 2
„ concrete	about	1
Portland stone	2
Sandstone	2 to 5
Yorkshire grit	3
Slate	5 to 10
Basalt	8 to 10
Granite	6 to 10
Brick, London Stock	¾ to 1¼
„ Staffordshire blue	2 to 6
Glass	10 to 15

III. Strength to resist Shearing.

Wrought-iron bars, across the direction of rolling	18 to 22
„ „ plates, „ „ „ „ „	16 to 20
„ „ „ in the plane of rolling	8 to 12
Mild steel	21 to 25
Cast-iron	6 to 13
Timber (along the fibre)	¼ to 1

IV. Moduluses of Elasticity.

	<i>E</i>	<i>C</i>
	Tons per square inch.	Tons per square inch.
Wrought-iron	12500 to 13500	5000 to 5500
Steel	13000 to 14000	5200 to 5700
Cast-iron	4500 to 7000	1700 to 2700
Copper, cast	5000 to 6000	1900 to 2300
„ rolled	5500 to 7500	2100 to 2900
Brass	5000 to 6500	2000 to 2300
Bronze	6000 to 7000	2300 to 2700
Gun-metal	5000	1900
Silver	4800	1800
Gold	5400	2100
Platinum	10500	4000
Phosphor bronze	6000	2300
Aluminium bronze	6500	2500
Timber, along the grain	600 to 950	

V. *Approximate Weights of Materials.*

	Lbs. per cubic foot.
Metals :—	
Wrought-iron	480
Steel	490
Cast-iron	430 to 470
" " grey foundry	450
Copper	550
Brass, cast	520
" rolled or drawn	530
Gun-metal	540
Aluminium, pure	162
" commercial	165 to 170
Zinc	450
Tin	465
Silver	655
Lead	710
Gold	1200
Platinum	1340
Timber :—	
Oak	50 to 55
White pine	25
Red pine	30 to 40
Pitch pine	40 to 45
Ash	45
Beech	43
Teak	40 to 55
Spanish mahogany	40 to 50
Stone, Brick &c. :—	
Limestone	125 to 175
Portland stone	144
Sandstone	135 to 145
Slate	175
Basalt	187
Granite	170
Masonry	116 to 144
Brickwork, ordinary	112
Concrete	120 to 130

INDEX.

- Annealing, 43
Arch, 231
— linear, 232
Arched rib, 233
— — hinged at ends and centre, 234
— — hinged at ends only, 236
— — fixed at ends, 239
Autographic stress-strain diagrams, 32, 75
Axial pull, 100
Ayrton, Prof., 201

Baker, Sir B., 56, 153
Barba, 47
Bauschinger, Prof., 55, 56, 76, 96, 97
Beams, deflection of, 132
— transverse bending of, 138
— continuous, 146
— resilience of, 139
— stress in, 112
Bending moment, 113
— — diagrams, 117
— — diagrams, how related to funicular polygon, 118
— — and shearing force, how related, 125
— of beams, 132
— of long columns, 175
— stress, 107
Blows and shocks, effects of, 59
Bollman truss, 172
Bottomley, J. T., 41
Bow, 161
Bulk modulus, 13

Cast-iron, test of, 31
— crushing of, 51
— data for, 93
— beams, 116
Catenary, common, 224
Centrifugal whirling of shafts, 204
Chain carrying loads, 221
— parabolic, 223
— inverted, 231
— loaded with its own weight, 224
Chaplin, Prof. W. S., 51
Christie's experiments on columns, 185
Clapeyron's Theorem of Three Moments, 149
Cold-shortness, 60
Columns, 174
— Euler's theory of, 175
— Gordon's formula, 182
Compression, failure by, 51
Connecting rod treated as a strut with lateral load, 192
Continuous beams, 146
— — advantages of, 151
Contraction of section in tensile tests, 44
Counterbracing in bridge frames, 170
Creeping in strain, 24
Crushing strength, table of, 243
Crystalline structure of metals, 46
Curvature of beams, 132
— — uniform, 133
— — anticlastic, 138
Cylinders subjected to internal pressure, 207

Deflection of beams, 131
— — due to shear, 144
Diagrams of strain and stress, 30
— autographic, 32

- Disc, revolving, 218
 Dunkerley, Prof., 206
- Ease, state of, 60
 Elastic compression of blocks, apparatus for measuring, 82
 Elastic modulus, table of, 248
 — strain, 10
 Elasticity, imperfection of, 57
 — — in cast-iron, 60
 Emery testing machine, 71
 Encasté beam, 158
 Euler's theory of columns, 175
 Ewing, J. A., experiments on overstrain, 35
 — crystalline structure of metals, 46
 — extensometer, 78
 Extension, non-elastic, 45
 — percentage of, 47
 Extensometers, 29, 76
 — Bauschinger's, 76
 — Unwin's, 77
 — Ewing's, 78
 — — for compression, 82
- Factor of safety, 27
 Fairbairn, 51, 52
 Fairbank's testing machine, 70
 Fatigue of metals, 54
 — — in elasticity, 56
 Fidler, Prof. C., 185
 Fink truss, 172
 Flow of solids, 33
 Forth Bridge, 153
 Fracture by tension or compression, 51
 — under successive blows, 59
 Frames, 157
 — perfect and imperfect, 158
 — redundant members in, 158
 — with semi-members, 159, 169
 — solution of by method of sections, 159
 — solution of by method of reciprocal figures, 160
 — superposed, 172
 — effects of stiff joints in, 178
 Funicular polygon, 123, 165
 Gordon's formula for columns, 181
 Greenhill, Prof., 203, 217
 Gun-barrel with initial stress, 215
 Hackney, W., 47
 Hadfield, R. A., 98
 Hanging chain, 221
 Hardening and tempering of steel, 44
 — of metals after overstrain, 33, 42
 Heat, influence of, on recovery from overstrain, 36
 Henrici, Prof., 161
 Hodgkinson, 81, 52, 94, 182
 Hooke's law, 11
 Hoop tension in cylinders, 207, 211, 214
 — in revolving ring, 217
 — — disc, 220
 Hysteresis, mechanical, 24, 58
 — — in overstrained steel, 39
 Imperfection of elasticity, 57
 Instability of long columns, 174
 Internal stress, initial, 60
 Isotropic material, equations of strain in, 20
 Kelvin, Lord, 58, 71
 Kennedy, Prof., 29, 49
 Kirkaldy, D., 30, 43, 45, 49, 53, 68
 Launhardt, 56
 Linear arch, 232
 Linville truss, 159
 Martens, Prof., 61
 Maxwell's needle, 91
 — method of reciprocal figures, 160
 Method of sections, 159
 Modulus of elasticity, Young's, 12, 16, 76, 84, 97
 — cubic compressibility, 13, 16
 — rigidity, 13, 16, 88, 90
 — rupture, 110
 Modulus of elasticity, relation between, 14, 16
 — — table of, 243
 Moving loads on beams, 126
 Muir, J., experiments on overstrain, 38

- Nickel steel, 98
- Overstrain, 25, 42
 — due to slips in crystals, 46
 — effect of in hardening metals, 33, 35
 — in breaking down elasticity, 35
 — experiments on, 35, 37, 38
- Pearson, Prof. Karl, 60
- Perfect frame, 158
- Permanent set, 10
- Perry, Prof., 187, 201
- Plasticity, 25
 — advantage of, 28
 — nature of in metals, 46
- Poisson's ratio, 12, 18
- Principal stresses, 4
 — — in a beam, 129
- Rankine's formula for columns, 182
- Reciprocal figures, 160, 162
- Redundant members in frames, 159
- Resilience, 14
 — of beams, 139
 — of shafts, 196
- Revolving disc, 218
 — ring, 217
- Rib, arched, 233
- Richards, E., 49
- Rigidity, modulus of, 13, 16, 88, 90
- Riveted joints, 49
- Rosenhain, W., crystalline structure of metals, 46
- Rupture, modulus of, 110
- Safety, factor of, 27
- Sections, method of, 159
- Semi-members, 159, 169
- Set, permanent, 10
- Shackles for testing machines, 68
- Shafts, torsion of, 190
 — centrifugal whirling of, 204
 — resilience of, 196
 — under end thrust and torsion, 203
- Shearing strength, table of, 243
 — force in beams, 113
 — — — diagrams of, 116
- Shearing stress, simple, 4, 7, 21
 — — equality of in two directions, 9
 — — in beams, distribution of, 127
- Shear modulus, 13
 — in tension and compression tests, 52
- Shells, 207
 — spherical, 210
 — of oval section, 210
- Simple bending, 107
- Single-lever testing machine, 63
- Slips in crystals of overstrained metal, 46
- Slope and deflection in beams, 134
- Spangenberg, 56
- Spiral springs, 198
- Steel, stress-strain diagrams of, 30
 — data for, 96
- Stiffening girders in suspension bridges, 226
- Strain, 10
 — elastic, 10
 — non-elastic, 24
 — — work done in, 14
 — simple, along one axis, 22
 — lateral, 12
 — hysteresis in, 53
- Strength, ultimate, 25
 — tables of, 241
- Stress, 2
 — intensity of, 2
 — distributed, 2, 99
 — normal, 3
 — tangential, 3
 — compressive, 4
 — tensile, 4
 — shearing, 4
 — principal, 4
 — character of in simple push or pull, 5
 — fluid, 10
 — uniformly varying, 102
 — in beams, 112
- Stress-strain diagrams, 30
 — — autographic, 32, 75
- Stretch modulus, 12
- Stromeyer, 61
- Struts, 174

- Struts with lateral load, 187
 St Venant, 203
 Superposed frames, 172
 Suspension-bridge chain, 223
 — — with stiffening girder, 226
- Tables of strength and elasticity, 241
 Temperature, influence of on strength, 60
 — influence of in producing recovery after over-strain, 36
- Tempering of steel, 44
 Tensile strength, table of, 241
 — tests, 29
- Testing machines, 29, 62
 — — calibration of, 66
 — — Werder's, 67
 — — Wicksteed's horizontal, 68
 — — diaphragm type, 70
 — — Emery's, 71
- Test-pieces, forms of, 48
 — long and short, comparative strength of, 50
- Theorem of three moments, 149
 Thick cylinder, 211
 — — exposed to external pressure, 214
 — — advantage of initial stress in, 214
- Thomasset testing machine, 71
 Thomson, James, 60
 Thurston, Prof., 61
 Time, influence of in testing, 41
 Torsion of shafts, 190
 — — in relation to power transmitted, 193
- Torsion of shafts beyond the elastic limit, 197
 — of non-circular shafts, 202
 Torsional oscillations, 90
 Tresca, 33
 Twisting combined with bending, 194
- Ultimate strength, 25
 Uniformly distributed stress, 99
 — varying stress, 101
 — — — analysis of, 105
 — — — forming a couple, 104
- Ujwin, Prof., 75, 94
 — — extensometer, 77
- Volume strain, 21
 Voussoirs of arch, 232
- Wade, Major, 68
 Warren girder, 159
 Webster, J. J., 61
 Weights of materials, table of, 244
 Werder testing machine, 67
 Weyrauch, 56
 Whirling of shafts, 204
 Wicksteed, J. H., 62, 68, 75
 Wire guns, 217
 Wöhler's experiments on the fatigue of metals, 55
 Work done in straining, 14
 Wrought-iron, data for, 94
- Yield-point, 29
 Young's modulus, 12
 — — measurement of, 76, 84, 86

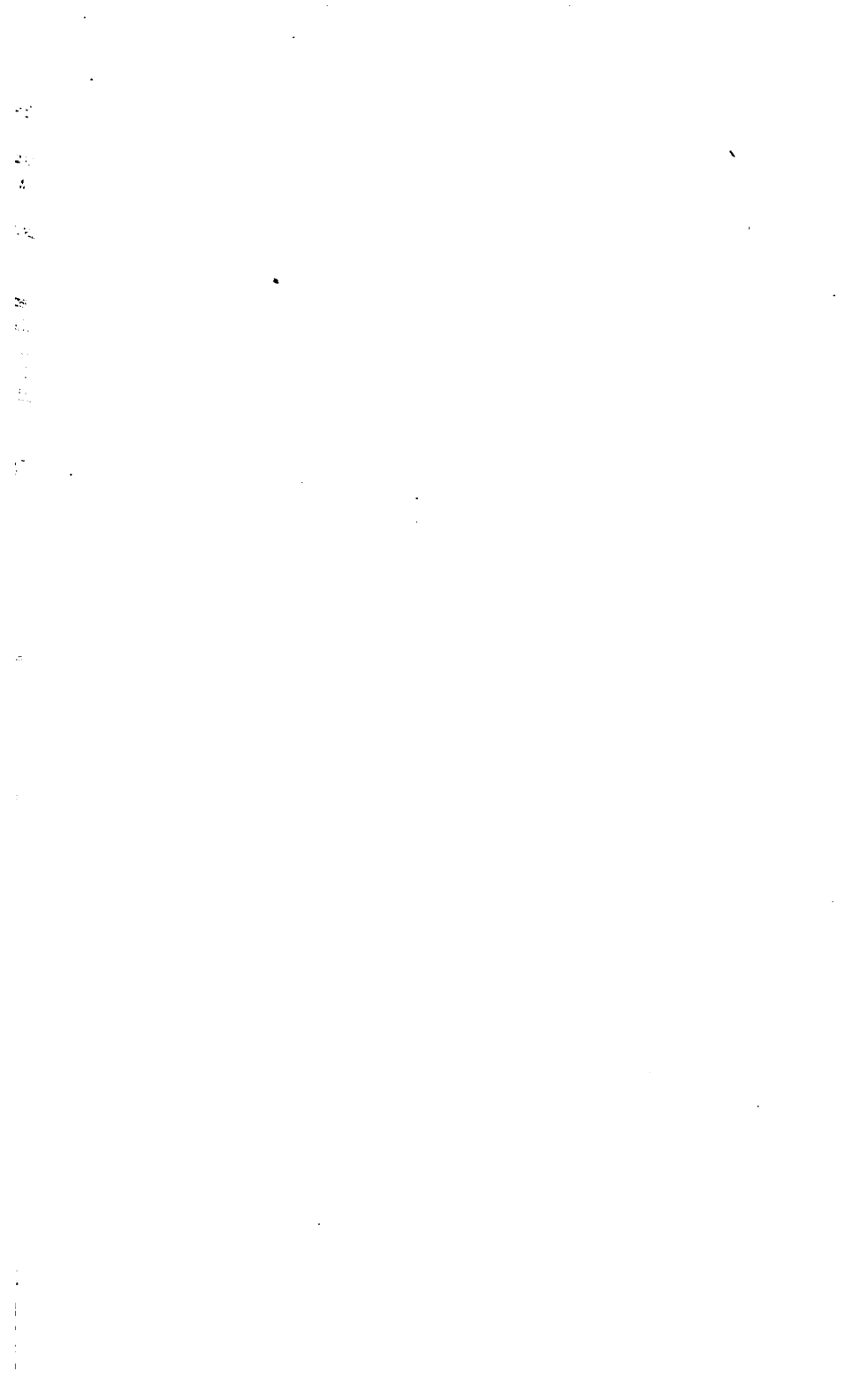

TA405 .E94x

The strength of materials

Loeb Design Library

ADE5213



3 2044 026 386 623

TA
405
.E94x

Ewing, J. A. (James Alfred), Sir, 1985-

The strength of materials / by J. A. Ewing. -- 2d ed. -- Cambridge, [Eng.] : The University Press, 1906.

xii, 248 p. : ill. ; 22 cm.

Includes index.

1. Strength of materials.

MH-SD ADE5213 870605

FLLMbn

